



DDRC810DT-GL Relay Controller

Designed to operate any type of switched load

The Philips Dynalite DDRC810DT-GL is ideal for controlling bi-directional motors, such as curtain and blind motors. It is an eight channel device suitable for any switched load up to 10A per channel, with a maximum box load of 40A.

- Voltage free changeover SPDT output relays — Perfect for controlling bi-directional motors.
- Flexible mounting solution — A DIN-rail mountable device, designed to be installed into the distribution board supplying power to the controlled circuit.
- Inbuilt diagnostic functionality — Features circuit run time tracking on each channel.
- Standalone or networked operation — Can operate as a discrete standalone unit, or as part of an integrated control system when connected to the DyNet network.

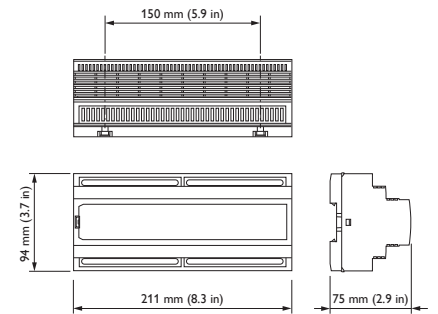

For detailed product information, please refer to the product information pages at www.philips.com/dynalite and follow the links.

Specifications

Due to continuous improvements and innovations, specifications may change without notice.

Item	Specification	Details
Electrical	Input Voltage	100 - 240 VAC 50 / 60 Hz Single Phase @ 0.25 A Active SMPS power consumption estimate is max. 8 W
	DyNet DC Supply	12 V @120 mA (supply for approx 6 user interfaces)
	Outputs	8 x switched SPDT voltage free changeover outputs Maximum ratings for each output: 10 A 250 VAC (resistive) 30 VDC (resistive) Maximum device load 40 A <small>Note: Snubbers/spark killers not fitted. De-rate for reactive loads. Functional isolation only between switched outputs. Do not mix SELV and non-SELV loads on the same device.</small>
Control	Control Inputs/Outputs	One DMX512 / RS-485 DyNet serial port One programmable dry contact AUX input
	User Controls	Service override switch Diagnostic LED
	Internal Controls	Programmable Logic Controller
	Preset Scenes	170
	Diagnostic Functions	Circuit run time tracking on each channel
Physical	Supply Terminals	Line, Neutral, Earth 2 x 2.5 mm ² or 1 x 4 mm ² maximum conductor size
	Output Terminals	C, NO, NC for each channel 1 x 4 mm ² maximum conductor size
	Dimensions (H x W x D)	94 mm x 211 mm x 75 mm (3.7" x 8.3" x 2.9")
	Packed Weight	0.82 kg
	Construction	Polycarbonate DIN-rail enclosure (12 unit)
	Operating Conditions	Temperature: 0 to 50° C ambient Humidity: 0 to 95% non-condensing
	Storage & Transport	Temperature: -25 to 60° C ambient Humidity: 0 to 90% non-condensing
Certification	Certification	CE, C-Tick
Options & Ordering	Standard Product	DDRC810DT-GL (Philips 12NC 913703052009)

Electrical Diagram

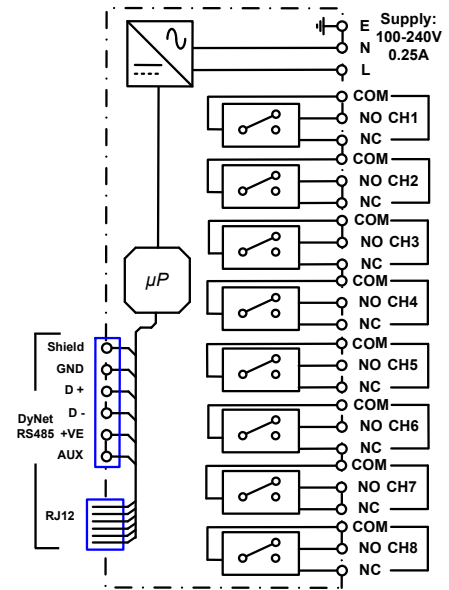

Philips Dynalite
6 / 691 Gardeners Road
Mascot, NSW 2020
Australia
Tel: +61 2 8338 9899
Email: dynalite.info@philips.com
Web: www.philips.com/dynalite

Specifications subject to change without notice. ©WMGD Pty Ltd Trading as Dynalite. Unit 6, 691 Gardeners Road Mascot 2020 Australia. ABN 33 097 246 921. All rights reserved. Dynalite, DyNet and associated logos are the registered trademarks of WMGD Pty Ltd. Not to be reproduced without permission.