

Solar Lighting Battery

ZJS60I

Mounting instruction/ 安装说明



IP68

12V
DC

Type 型号	Capacity/Ah 容量/安时	Net Weight/kg 净重 / 公斤	Gross Weight/kg 毛重 / 公斤	Package Size/cm 包装尺寸/厘米
ZJS60I 60AH 12.8V Battery	60AH	8.5	9.5	15.6x22.2x58.5
ZJS60I 100AH 12.8V Battery	100AH	12.2	13.2	15.6x22.2x58.6

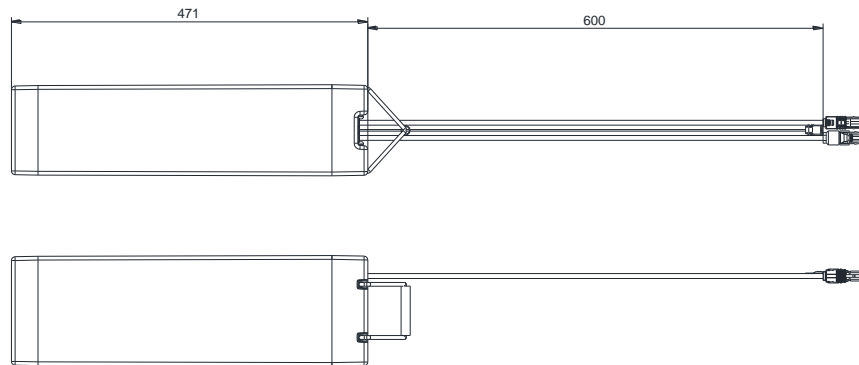
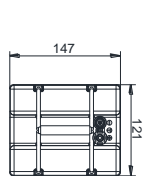

Dimension in mm
单位: 毫米

Type 型号	Net Weight/kg 净重 / 公斤	Gross Weight/kg 毛重 / 公斤	Package Size/cm 包装尺寸/厘米
Batteries kits for parallel connection	4.2	4.7	33x33x15

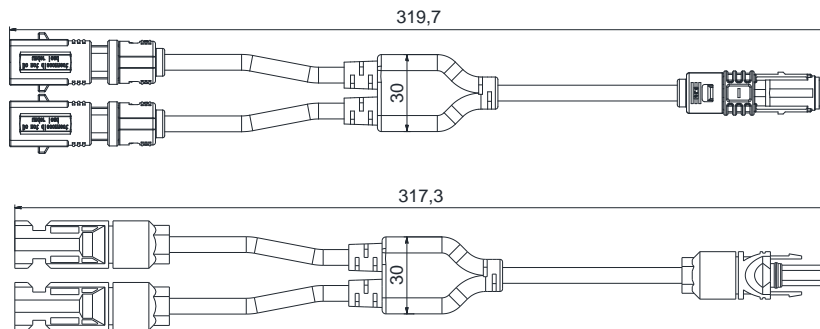

Dimension in mm
单位: 毫米



1. Only be charged with authorized charger, limited voltage in charge 14.2V;
必须使用授权的充电器给电池充电, 限制电压14.2V;
2. Do not use or leave the battery near a heat source as fire to avoid explosion
不要把电池放在热源(如: 火)附近, 以防爆炸
3. Do not make short circuit, extrusion, and puncture
禁止电路短接, 禁止挤压、刺穿电池,
4. Do not immerse the battery in water or throw in the fire
禁止将电池浸在水中, 或丢进火中
5. Do not tamper or disassemble the battery
不要损害或拆解电池
6. The battery should be replaced immediately if any crack or deterioration.
若电池有破损, 请勿继续使用

Philips Lighting (China) Investment Co., Ltd.
Building No. 9, Lane 888, Tianlin Road, Minhang District,
Shanghai, China
飞利浦照明(中国)投资有限公司
中国上海市闵行区田林路888弄9号楼
邮编: 200233

PHILIPS

Connect diagram 连接示意图

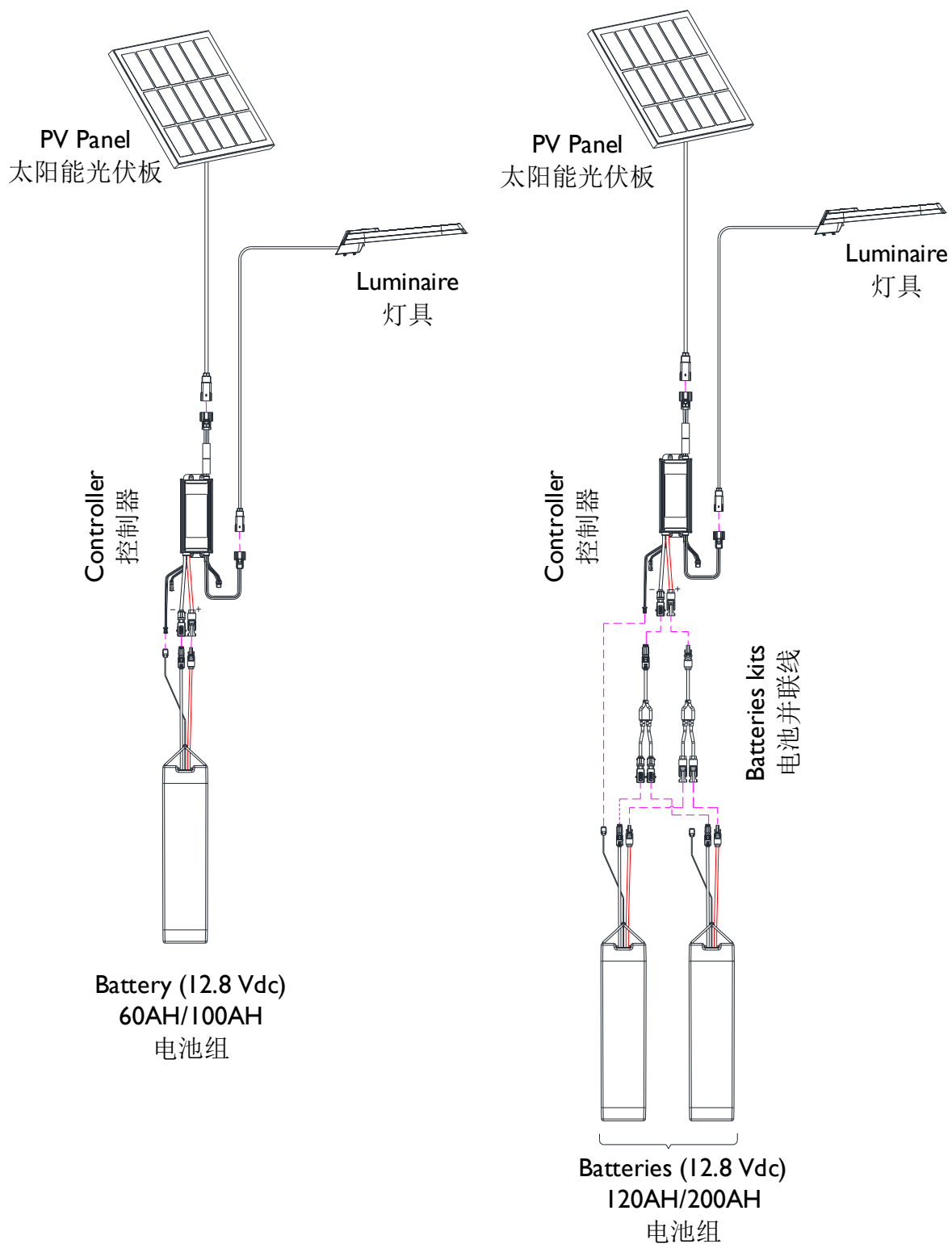

1. For 60Ah and 100Ah battery ,Connect the battery to the controller directly.

针对60安时和100安时的电池，直接将电池与控制器连接

2. For the 120Ah or 200Ah battery, Firstly parallel connection two 60Ah or 100Ah batteries by the batteries kits, then connect to the controller.

针对120安时或200安时的电池，首先用电池并联线将两个60安时或100安时的电池并联，然后再与控制器连接。