

INSTALLATION INSTRUCTIONS

BRM 832 & 836 LED BOLLARD WITH DEMAND RESPONSE

IMPORTANT! Be sure electrical power is off before installing luminaire.

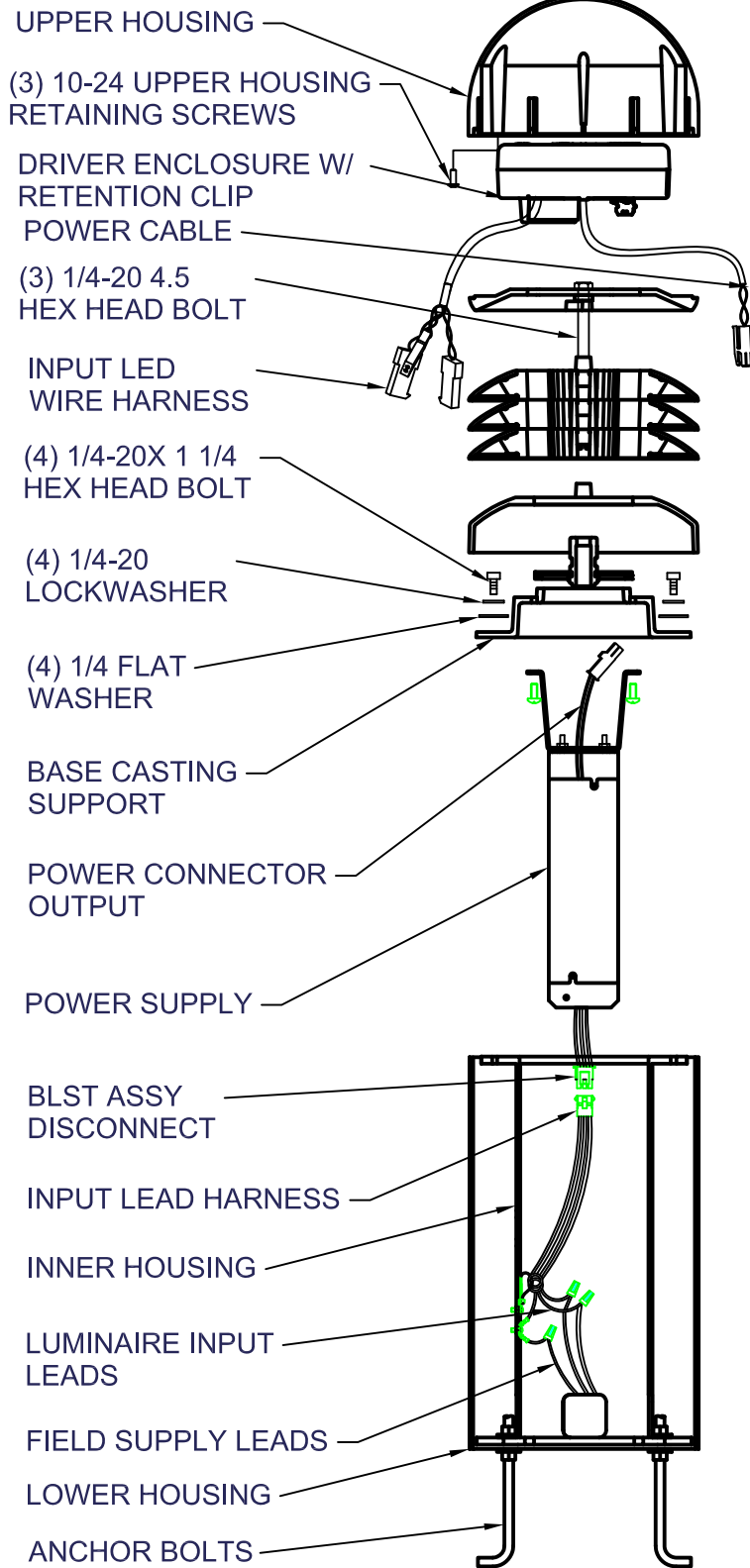

INSTALLATION PROCEDURE

1. To install luminaire, remove assembled luminaire from shipping container.
2. Be sure electrical power is turned off.
3. Loosen (3) 10-24 upper housing retaining screws two full turns with a 1/8" ball driver. Rotate upper housing counterclockwise slightly and remove upper dome housing.
4. On the bottom side of driver enclosure press on spring clip with a flat head screwdriver and pull up on driver to gain access to wire way and proceed to disconnect harnesses from louvers.
5. Remove 1/4-20 screws & lock washers from the luminaire head assembly. The luminaire head assembly can now be lifted to expose quick disconnects. Disengage connection and place luminaire head assembly aside.
6. Remove (4) 1/4-20 hex head bolts, split lock washers & flat washers. Slide base casting, ballast assembly & gasket high enough to disconnect quick disconnects & set aside for now.
7. Slide lower housing off, exposing inner housing
8. Making sure field supply leads extend out of conduit an appropriate length, install inner housing onto anchor bolts. Level inner housing using leveling nuts & washers and tighten.
9. Splice field supply leads to luminaire input leads through 2" X 4" handhole.
10. Reinstall lower housing onto inner housing,
11. Connect ballast assembly quick disconnect to luminaire input lead harness and slide power supply assembly into inner housing and secure with (4) 1/4-20 bolts, flat & split washers
12. Reconnect quick disconnects & together and place luminaire head assembly back in proper location. Secure with proper 1/4-20 screws.
13. Reinstall LED louvers to the and make sure that all the connectors line up so that the LEDs in line.
14. Connect power supply cable to the single driver power cable and connect input cable to each of the louvers. Make sure that the connect is properly mated.
14. Reinstall upper housing and tighten (3) 10-24 upper housing retaining screws. Luminaire installation is complete.
15. Energize luminaire.

