



Gardco SlenderForm SFA luminaires combine LED performance excellence and advanced Gardco LED thermal management technology with a distinct styling to provide outdoor area lighting that is both energy efficient and aesthetically pleasing. SlenderForm is defined by its high performance, sleek low profile design and rugged construction.

Project: \_\_\_\_\_  
 Location: \_\_\_\_\_  
 Cat.No: \_\_\_\_\_  
 Type: \_\_\_\_\_  
 Lamps: \_\_\_\_\_ Qty: \_\_\_\_\_  
 Notes: \_\_\_\_\_

Ordering guide

example SFA-32L-250-NW-G2-AR-2-120-DD-F1-SPA1-BK

Prefix	Number of LEDs	Drive Current	LED Color/ Generation	Mounting	Distribution	Voltage	Controls	Electrical	Luminaire	Finish
<b>SFA</b>	-	-	-	-	-	-	-	-	-	-
SFA SlenderForm Square Standard Arm Mount luminaire	<b>32L</b> 32 LEDs	<b>250</b> 250mA	<b>NW-G2</b> Neutral White 4000K, 70CRI Gen 2	<b>AR</b> Arm mount (mounts to a 4" round pole)	<b>2</b> Type 2	<b>120</b> 120V	<b>DD</b> 0-10V Dimming Driver <sup>1</sup> <b>Infrared Motion Response Systems</b> <b>IMRI3</b> Integral with #3 lens <b>DynaDimmer: Automatic Profile Dimming</b> <b>CS50</b> Safety 50% Dimming, 7 hours <sup>2</sup> <b>CM50</b> Median 50% Dimming, 8 hours <sup>2</sup> <b>CE50</b> Economy 50% Dimming, 9 hours <sup>2</sup> <b>DA50</b> All Night 50% Dimming <sup>2</sup> <b>Photoelectric/Receptacle Systems</b> <b>PCB</b> Photocontrol Button <sup>3,4</sup> <b>TLRD5</b> Twist Lock Receptacle 5-Pin <b>TLRD7</b> Twist Lock Receptacle 7-Pin <b>TLRPC</b> Twist Lock Receptacle with Photocell <sup>3</sup> <b>Pole Mounted Infrared Motion Response Systems with DynaDimmer</b> <b>CS50-IMRO</b> with Safety 50% dimming <sup>2,6</sup> <b>CM50-IMRO</b> with Median 50% dimming <sup>2,6</sup> <b>CE50-IMRO</b> with Economy 50% dimming <sup>2,6</sup> <b>DA50-IMRO</b> with All Night 50% dimming <sup>2,6</sup>	<b>Fusing</b> <b>F1</b> Single (120, 277, 347VAC) <sup>3</sup> <b>F2</b> Double (208, 240, 480VAC) <sup>3</sup> <b>F3</b> Canadian Double Pull (208, 240, 480VAC) <sup>3</sup> <b>Pole Mount Fusing</b> <b>FP1</b> Single (120, 277, 347VAC) <sup>3</sup> <b>FP2</b> Double (208, 240, 480VAC) <sup>3</sup> <b>FP3</b> Canadian Double Pull (208, 240, 480VAC) <sup>3</sup> <b>Surge Protection</b> <b>SP1</b> Standard 10KVA <b>SP2</b> Increased 20KVA	<b>SPA1</b> Square Pole Adapter <b>HIS</b> Internal House Side Shield (not available with Type 5) <b>DL</b> Diffuse lens (not available with 64L)	<b>Textured</b> <b>BK</b> Black <b>WH</b> White <b>BZ</b> Bronze <b>DGY</b> Dark Gray <b>MGY</b> Medium Gray <b>Customer specified</b> <b>RAL</b> Specify optional color or RAL (ex: OC-RAL7024) <b>CC</b> Custom color (Must supply color chip for required factory quote)
	<b>48L</b> 48 LEDs	<b>700</b> 700mA	<b>WW-G2</b> Warm White 3000K, 70CRI Gen 2		<b>2-90</b> Type 2 Rotated left 90°	<b>208</b> 208V				
	<b>64L</b> 64 LEDs	<b>850</b> 850mA	<b>CW-G2</b> Cool White 5700K, 70CRI Gen 2		<b>2-270</b> Type 2 Rotated right 270°	<b>240</b> 240V				
					<b>3</b> Type 3	<b>277</b> 277V				
					<b>3-90</b> Type 3 Rotated left 90°	<b>347</b> 347V				
					<b>3-270</b> Type 3 Rotated right 270°	<b>480</b> 480V				
					<b>4</b> Type 4	<b>UNV</b> 120-277V (50/60Hz)				
					<b>4-90</b> Type 4 Rotated left 90°	<b>HVU</b> 347-480V (50/60Hz)				
					<b>4-270</b> Type 4 Rotated right 270°					
					<b>5</b> Type 5					

1. DD option is required for pole mount motion sensor.  
 2. Available only on 120, 208, 240, and 277 (or UNV).  
 3. Specify input voltage.  
 4. Not available with 347V or 480V.  
 5. HIS not available with Type 5.  
 6. Pole mounted sensor must be ordered separately (See accessories page).



# SFA SlenderForm LED luminaire

## Site & Area – Square Arm Mount

### Accessories (order separately)

#### House Side shield

Standard orientation:

**HIS-32-V** Internal House Side Shield for 32 LEDs (2 modules)

**HIS-48-V** Internal House Side Shield for 48 LEDs (3 modules)

**HIS-64-V** Internal House Side Shield for 64 LEDs (4 modules)

At 90° or 270° orientation:

**HIS-32-H** Internal House Side Shield for 32 LEDs (2 modules)

**HIS-48-H** Internal House Side Shield for 48 LEDs (3 modules)

**HIS-64-H** Internal House Side Shield for 64 LEDs (4 modules)

#### Pole top fitter

**PTF2-(F)** fits 2-3/8-2 1/2" OD x 4" depth tenon with 1, 2, 3 or 4 luminaires at 90°

**PTF3-(F)** fits 3-3 1/2" OD x 6" depth tenon with 1, 2, 3 or 4 luminaires at 90°

**PTF4-(F)** fits 3-1/2-4" OD x 6" depth tenon with 1, 2, 3 or 4 luminaires at 90°

(F) = Specify finish

#### Pole Mount Motion Sensor

**MS-A-120V** 120V Input

**MS-A-277V** 277V Input

(DD or Dynadimmer option required)

### LED Wattage and Lumen Values Standard SFA Arm Mount luminaires

Order Code	LED Qty	System Current (mA)	Color Temp (K)	Ave System Watts <sup>1</sup> (W)	Type 2			Type 3			Type 4			Type 5		
					Lumen Output <sup>2,3</sup>	BUG Rating	Efficacy (lm/W)	Lumen Output <sup>2,3</sup>	BUG Rating	Efficacy (lm/W)	Lumen Output <sup>2,3</sup>	BUG Rating	Efficacy (lm/W)	Lumen Output <sup>2,3</sup>	BUG Rating	Efficacy (lm/W)
SFA-32L-250-NW-G2-x	32	250	4000	27	3407	B1-U0-G1	129	3207	B1-U0-G1	121	3319	B1-U0-G1	125	3458	B2-U0-G1	130
SFA-32L-500-NW-G2-x	32	500	4000	51	6459	B2-U0-G1	127	6079	B1-U0-G2	120	6292	B1-U0-G2	124	6555	B3-U0-G1	129
SFA-48L-700-NW-G2-x	48	700	4000	104	12336	B3-U0-G2	118	11609	B2-U0-G2	111	12017	B2-U0-G2	115	12519	B4-U0-G2	120
SFA-64L-850-NW-G2-x	64	850	4000	168	19216	B3-U0-G2	115	18084	B3-U0-G3	108	18719	B3-U0-G3	112	19501	B5-U0-G3	116

1. Wattage may vary by +/- 8% due to LED manufacturer forward volt specification and ambient temperature. Wattage shown is average for 120V through 277V input. Actual wattage may vary by an additional +/- 10% due to actual input voltage.

2. Values shown are for luminaires without the DL options. Contact outdoorlighting.applications@philips.com if any approximate estimates are required for design purposes.

3. Lumen values based on tests performed in compliance with IESNA LM-79.

### Dimensions – SFA

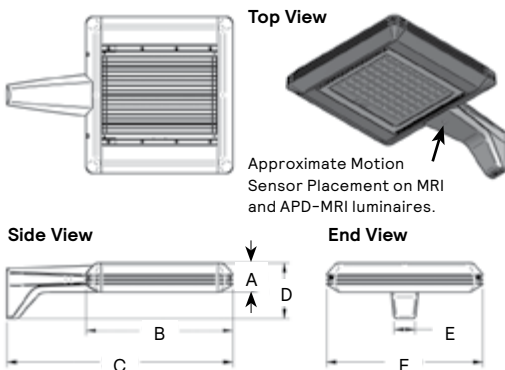

#### Effective Projected Area ft<sup>2</sup> / m<sup>2</sup>

Type	Single	Twin @ 180	3/4
SFA	0.52 / 0.050	1.04 / 0.097	1.38 / 0.128

#### Single Luminaire Weight

SFA	26 lbs / 11.794 kgs
-----	---------------------

#### Dimensions: Inches / Centimeters

A	3.00" / 7.62cm
B	15.17" / 38.532cm
C	23.30" / 59.182cm
D	5.75" / 14.605cm
E	2.18" / 5.537cm
F	16.10" / 40.894cm

# SFA SlenderForm LED luminaire

## Site & Area - Square Arm Mount

### Luminaire Configuration Information

#### Dimming (DD)

Philips Gardco SlenderForm LED luminaire provided with 0 -10V dimming for connection to a control system provided by others..

#### Dynadimmer Automatic Profile Dimming

Automatic dimming profiles (CS50/CM50/CE50) offer safety, median, or economy settings, for shorter or longer duration. Dimming profiles provide flexibility towards energy savings goals while optimizing light levels during specific dark hours. 50% dimming is standard. DA50 offers 50% instantaneous dimming all night (during all dark hours). 75% and 25% dimming is also available if different light levels are required (contact Technical Support for details).

Profile	Dimming		
	Level	Duration	Example
Economy	50%	9 hours	9AM - 6PM
Median	50%	8 hours	10AM - 6PM
Safety	50%	7 hours	11AM - 6PM
Reactive 50	50%	dynamic	all night

**TLRD5:** Twist Lock Receptacle with 5 pins enabling dimming, can be used with a twistlock photoelectric cell or a shorting cap. Can also be used with Philips or third party control system. Receptacle located on top of luminaire housing.

**TLRD7:** Twist Lock Receptacle with 7 pins enabling dimming and additional functionality (by others), can be used with twistlock photoelectric cell or a shorting cap. Can also be used with Philips or third party control system. Receptacle located on top of luminaire housing.

**TLRDPC:** Receptacle with twistlock photoelectric cell (must specify voltage). Receptacle located on top of luminaire housing.

**IMRI3:** Infrared Motion Response Integral. IMRI module is mounted integral on arm and is available with sensor lens type #3. Motion response for option IMRI is set/operates in the following fashion: The motion sensor is set to a constant 50%. When motion is detected by the PIR sensor, the luminaire returns to full power/light output. Dimming on low is factory set to 50% with 5 minute default in "full power" prior to dimming back to low. When no motion is detected for 5 minutes, the motion response system reduces the wattage by 50%, to 50% of the normal constant wattage reducing the light level. IMRI can also be specified with automatic profile dimming for the added benefit of a combined dimming profile with sensor detection, where the PIR sensor will override the dimming profile when occupancy is detected. Passive infrared (PIR) motion sensor.

#### Side Coverage Pattern

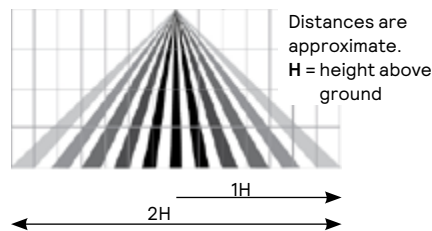

#### Top Coverage Pattern

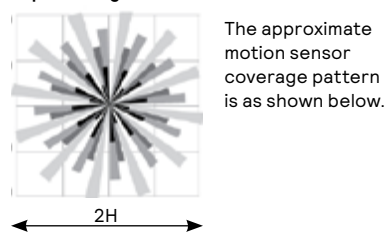

**IMRO:** Infrared Motion Response Outboard pole mounted sensor, must be specified with an available automatic profile dimming option. Combines the benefits of both automatic profile dimming and motion response using the Philips DynaDimmer technology. PIR sensor features a pole mounted Wattstopper EW-200-120-W or the EW-200-277-W. One motion sensor per pole is required (order MS-A-120 or MS-A-277 separately). Available in 120 or 277V only. IMRO sensors require single voltage 120V or 277V input (see chart for approximate detection patterns). If motion is detected during the time that the luminaire is operating at profile dimming mode specified, the luminaire returns to 100% power and light output. The luminaire remains on high until no motion is detected for the duration period, after which the luminaire returns back to automatic profile dimming. Duration period is factory set at 15 minutes, and is field adjustable from 5 minutes up to 15 minutes. The area motion detector provides coverage equal to up to 6 times the sensor height above ground, 270° from the front-center of the sensor.

**Pole Details:** IMRO requires that the pole include an additional hand hole 15 feet above the pole base, normally oriented 180° to the standard hand hole. For Philips Gardco poles, order the pole with the Motion Sensor Mounting (MSM) option which includes the hand hole and a special hand hole cover plate with a 1/2" NPT receptacle centered on the hand hole cover plate into which the motion sensor mounts. Once the motion sensor is connected to the hand hole cover plate, then wiring connections are completed in the pole. The plate (complete with motion sensor attached and wired) is then mounted to the hand hole. If poles are supplied by others, the customer is responsible for providing suitable mounting accommodations for the motion sensor in the pole (see Gardco Poles specification sheets for more information).

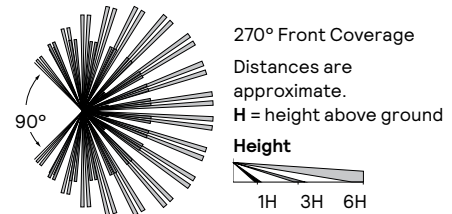

#### Mounting to a Philips Gardco Pole:

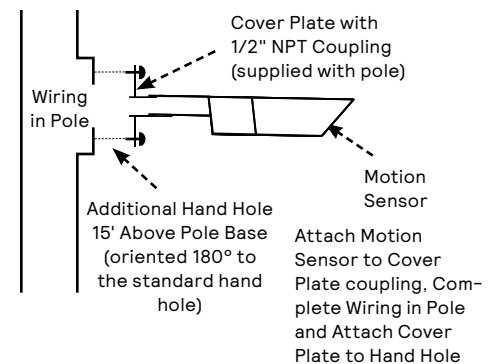

**F1:** Fusing Single (for 120, 277 or 347VAC)

**F2:** Fusing Double (for 208, 240 or 480VAC)

**FP1:** Fusing Pole Single (pole mounted near handhole, for 120, 277 or 347VAC)

**FP2:** Fusing Pole Double (pole mounted near handhole, for 208, 240 or 480VAC).

**FP3:** Fusing Pole Canadian Double Pull (pole mounted near handhole, for 208, 240 or 480VAC)

**SP1:** Surge Protection, 10kV/5kA, 120-277V or 347-480V

**SP2:** Surge Protection, 20kV/10kA, 120-277V or 347-480V

**HIS:** Internal House Side Shield. Injection molded in black finish. Ships installed with 1 per 16 LED module. Also available shipped separately as an accessory for 2-4 LED modules.

# SFA SlenderForm LED luminaire

## Site & Area - Square Arm Mount

### Asymmetric Optical Orientation Information

#### Standard Optic Position

Luminaires ordered with asymmetric optical systems in the standard optic position will have the optical system oriented as shown below:

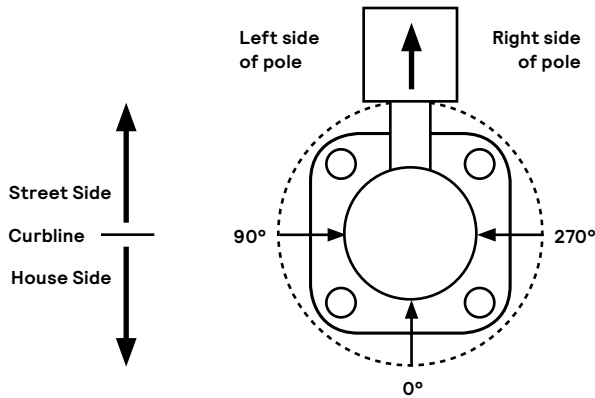

Note: The hand hole will normally be located on the pole at the 0° point.

#### Optic Rotated Left (90°) Optic Position

Luminaires ordered with asymmetric optical systems in the Optic Rotated Left (90°) optic position will have the optical system oriented as shown below:

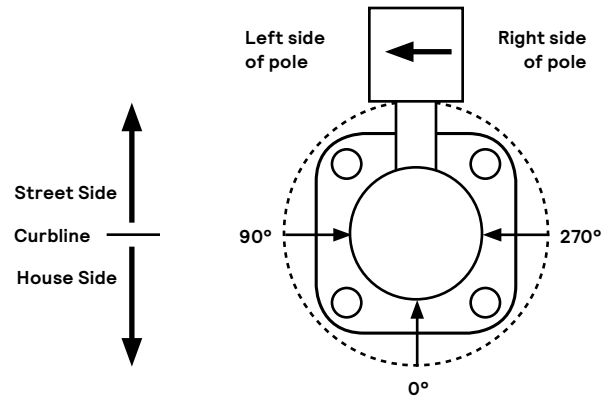

Note: The hand hole will normally be located on the pole at the 0° point.

### Asymmetric Optical Orientation Information

#### Optic Rotated Right (270°) Optic Position:

Luminaires ordered with asymmetric optical systems in the Optic Rotated Right (270°) optic position will have the optical system oriented as shown below:

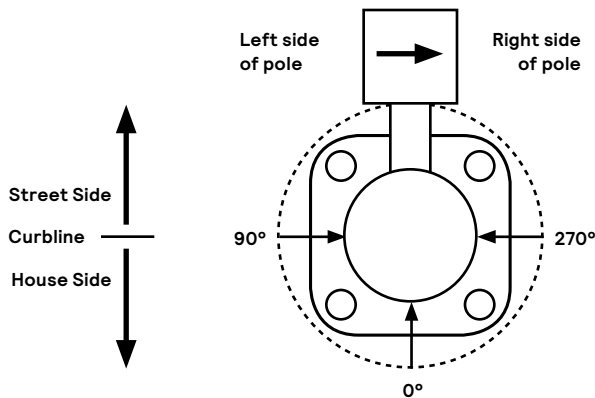

Note: The hand hole will normally be located on the pole at the 0° point.

#### Twin Luminaire Assemblies With Rotated Optical Systems

Twin luminaire assemblies installed with rotated optical systems are an excellent way to direct light toward the interior of the site (Street Side) without additional equipment. It is important, however, that care be exercised to insure that luminaires are installed in the proper location.

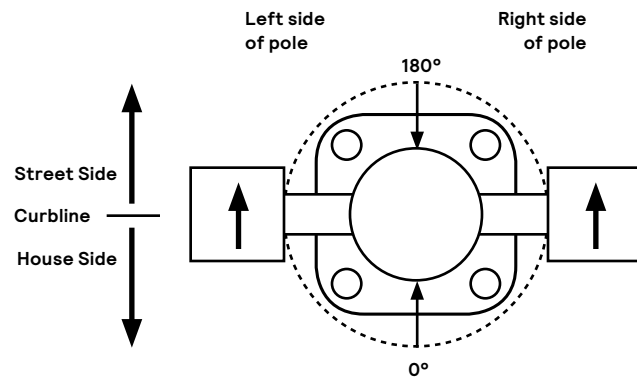

Luminaires with Optic Rotated Right (270°) are installed on the LEFT Side of Pole

Luminaires with Optic Rotated Left (90°) are installed on the RIGHT Side of Pole

Note: The hand hole location will depend on the drilling configuration ordered for the pole.

# SFA SlenderForm LED luminaire

## Site & Area – Square Arm Mount

### Specifications

#### Housing

The Gardco SlenderForm housing consists of a rugged extruded aluminum housing body with an integral LED thermal management system, with die cast aluminum end caps. SFA luminaires arrive with the arm factory installed. As a result, the luminaires provide the functionality, strength and installation ease of an integral arm luminaire.

#### IP Rating

SlenderForm light engines have a rating of IP66.

#### Vibration Resistance

SlenderForm carries a 3G vibration rating that conforms to standards set forth by ANSI C136.31. Testing includes vibration to 3G acceleration in three axes, all performed on the same luminaire.

#### Electrical

Luminaires are equipped with an LED driver that accepts 120V through 277V, or 347V through 480V, 50hz to 60hz, input. Driver output is based on the LED wattage selected. Component-to-component wiring within the luminaire will carry no more than 80% of rated current and is listed by UL for use at 600 VAC at 302°F / 150°C or higher. Plug disconnects are listed by UL for use at 600 VAC, 15A or higher. Power factor is not less than 90%. Luminaire consumes 0.0 watts in the off state. All motion sensors utilized consume 0.0 watts in the off state. Surge protector standard. 10KA per AN SI/IEEE C62.41.2.

#### LED Thermal Management

The Philips Gardco SlenderForm LED provides integral thermal radiation fins to provide the excellent thermal management so critical to long LED system life.

#### FULL Cutoff performance

Full cutoff performance means a luminaire distribution where zero candela intensity occurs at an angle at or above 90° above nadir. Additionally, the candela per 1000 lamp lumens does not numerically exceed 100 (10 percent) at a vertical angle of 80° above nadir. This applies to all lateral angles around the luminaire.

#### Optical Systems

The advanced LED optical systems provide IES Types II, III, IV and V distributions. All optical systems feature unitized lens optic construction. SlenderForm luminaires are provided standard with with sealed light engines with no glass lens, for maximized performance. A diffuse lens is available as an option, resulting in reduced performance. All SlenderForm luminaires provide full cutoff performance.

#### Listings

All luminaires bear UL or CUL (where applicable) Wet Location labels.

#### Finish

Each standard color luminaire receives a fade and abrasion resistant, electrostatically applied, thermally cured, triglycidic isocyanurate (TGIC) textured polyester powdercoat finish. Standard colors include bronze (BZ), black (BK), white (WH), dark gray (DGY), and medium gray (MGY). Consult factory for specs on optional or custom colors.

#### Warranty

Gardco luminaires feature a 5 year limited warranty. Gardco LED luminaires with LED arrays feature a 5 year limited warranty covering the LED arrays. LED Drivers also carry a 5 year limited warranty. Motion sensors are covered by warranty for 5 years by the motion sensor manufacturer. See Warranty Information on [www.signify.com/warranty](http://www.signify.com/warranty) for complete details and exclusions.

#### Predicted Lumen Depreciation Data

Ambient Temperature °C	System Current	LED Current	Calculated L <sub>70</sub> hrs <sup>1,2</sup>	L <sub>70</sub> per TM21 <sup>2,3</sup>	Lumen Maintenance @ 60,000hrs
25 °C	850 mA	850 mA	>100,000	>60,000	96%

1. Predicted performance derived from LED manufacturer's data and engineering design estimates, based on IESNA LM-80 methodology. Actual experience may vary due to field application conditions.
2. L70 is the predicted time when LED performance depreciates to 70% of initial lumen output.
3. Calculated per IESNA TM 21-11. Published L70 hours limited to 6 times actual LED test hours.

The information presented in this document is not intended as any commercial offer and does not form part of any quotation or contract.

