

# INSTALLATION INSTRUCTIONS

## 940 LINE-INCANDESCENT CONCRETE CONSTRUCTION

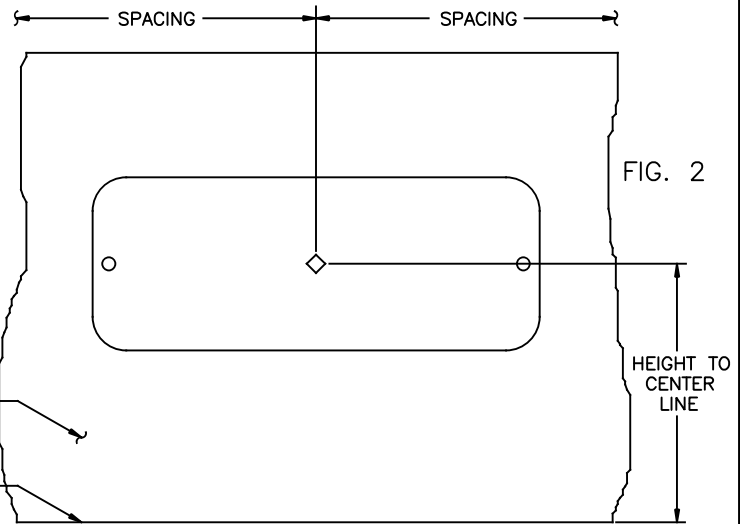
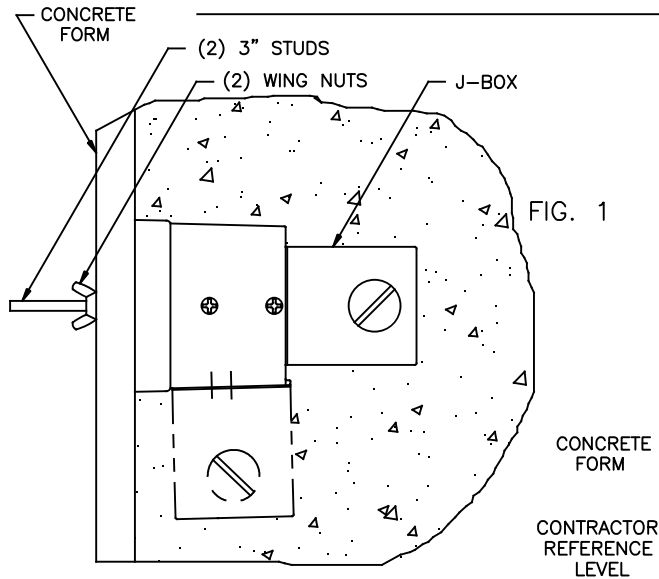

### IMPORTANT

BE SURE ALL POWER IS OFF PRIOR TO INSTALLING FIXTURES. READ ALL INSTRUCTIONS BEFORE PERFORMING ANY WORK.

### HOUSING INSTALLATION

1. REMOVE HOUSING ASSEMBLY AND MOUNTING KIT CONTAINING CHIPBOARD TEMPLATE, 3" LOCATING STUDS AND WINGNUTS FROM CARTON.
2. THE J-BOX IS MOUNTED ON THE BACK OF THE HOUSING AT THE FACTORY. THE J-BOX MAY BE REPOSITIONED TO THE BOTTOM OF THE HOUSING AS REQUIRED. THE COVER PLATE MUST BE SECURED OVER THE UNUSED J-BOX ACCESS OPENING.
3. ATTACH THE 3" LOCATING STUDS TO HOUSING PER FIGURE 1. LEAVE SCREWS ON OUTSIDE OF HOUSING IN PLACE.
4. USE DIMENSIONS PROVIDED BY SITE CONTRACTOR TO MARK HOUSING CENTER-LINE LOCATIONS ON OUTSIDE OF CONCRETE FORMS.
5. POSITION AND LEVEL TEMPLATE OVER HOUSING CENTERLINE PER FIGURE 2. MARK HOLE LOCATIONS FOR 3" LOCATING STUDS USING TEMPLATE AS A GUIDE.
6. DRILL HOLES THROUGH FORMS USING A 1/4" DRILL BIT.
7. INSTALL HOUSING ASSEMBLY ON CONCRETE SIDE OF FORMS. INSERT 3" LOCATOR STUDS THROUGH THE HOLES CREATED IN STEP 6 PER FIGURE 1. TAKE CARE TO ORIENT THE HOUSING PER FIGURE 1 AND ARROW IN HOUSING. SECURE WITH WING NUTS FROM MOUNTING KIT PROVIDED.

- NOTE: THE FRONT OF THE HOUSING WILL BE FLUSH WITH SURFACE OF THE CONCRETE BY FOLLOWING THE PREVIOUS PROCEEDURE. IF A SURFACE FINISH SUCH AS TILING IS PLANNED, ALLOWANCES MUST BE MADE IN MOUNTING THE HOUSING PRIOR TO POURING THE CONCRETE TO INSURE FLUSHNESS.
8. SUPPLY POWER TO FIXTURE THROUGH J-BOX 3/4" HUBS. ONLY REMOVE THE HUB PLUGS NECESSARY FOR THE INSTALLATION.
  9. BRANCH CIRCUIT WIRING TO BE INSTALLED PER NEC OR APPLICABLE LOCAL CODES.
  10. REMOVE WINGNUTS AND STUDS ONCE CONCRETE HAS CURED. THIS MUST BE DONE PRIOR TO REMOVING CONCRETE FORMES.

### IMPORTANT

AT ALL TIMES WIRING TO BE DONE PER THE NEC OR APPLICABLE LOCAL CODES.

# INSTALLATION INSTRUCTIONS

## 940 LINE-INCANDESCENT CONCRETE CONSTRUCTION

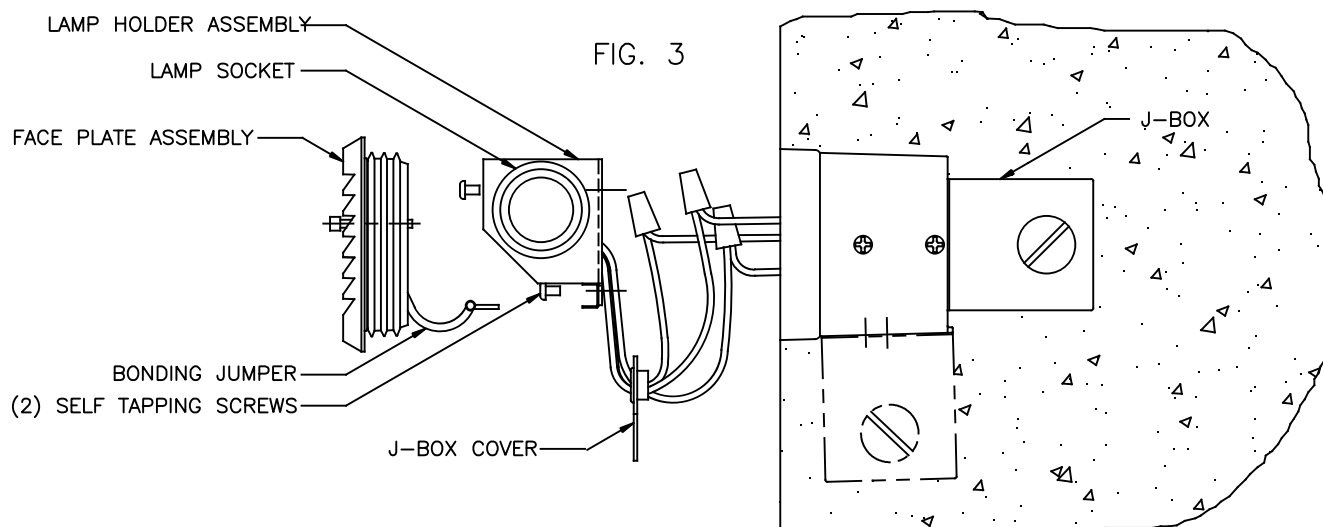

### WIRING, LAMP HOLDER ASSEMBLY AND FACE PLATE INSTALLATION

1. REMOVE LAMP HOLDER ASSEMBLY AND FACE PLATE ASSEMBLY FROM CARTON.
2. PLACE LAMP HOLDER ASSEMBLY IN HOUSING AND SECURE WITH (2) SELF TAPPING SCREWS.
3. MAKE ELECTRICAL CONNECTIONS. FIXTURE LINE (BLACK) TO SUPPLY LINE. COMMON (WHITE) TO SUPPLY COMMON AND GROUND (GREEN) TO GROUND.
4. CAREFULLY PLACE SPLICES AND EXCESS WIRE INTO J-BOX. BACK OUT J-BOX COVER SCREWS AS REQUIRED TO ALLOW THE J-BOX COVER TO SLIDE UNDER THESE SCREWS. TIGHTEN SCREWS. PUSH ANY EXCESS WIRE STILL IN THE HOUSING THROUGH THE J-BOX COVER BUSHING.
5. INSTALL LAMP (BY OTHERS).
6. CONNECT FACE PLATE BONDING JUMPER TO TAB ON LAMP HOLDER ASSEMBLY.
7. INSTALL FACE PLATE ASSEMBLY BEING CAREFULL NOT TO OVER TIGHTEN THE SCREWS.

