

bodine

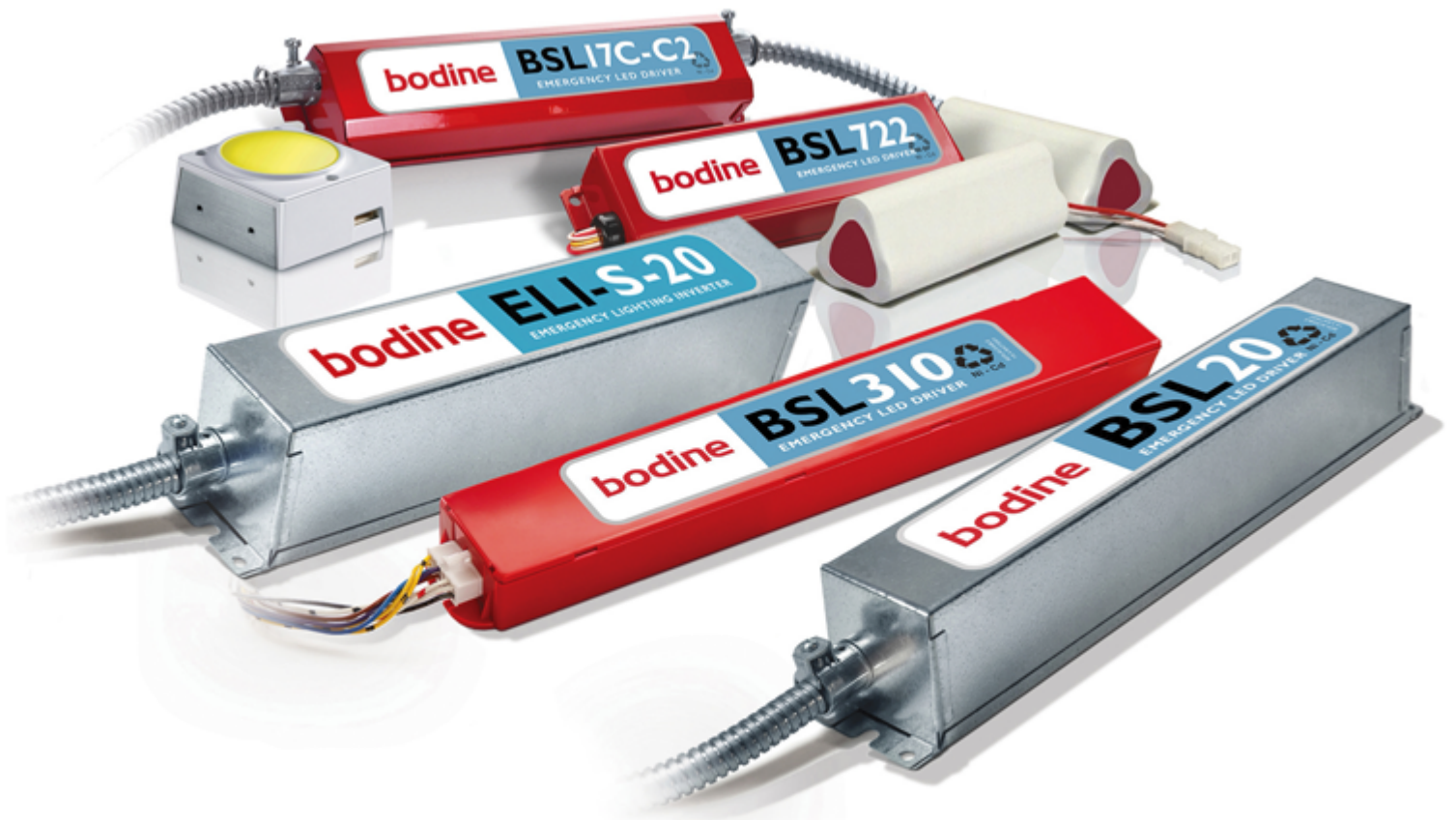

Technology designed to fit

Emergency

Product Solutions





Contents

Emergency lighting is code required	2	UltimateOne combination driver	16-17
Two sources of power	3	Selecting EM LED drivers	18-19
Life safety code	4	Selection guide table	20-21
Code required testing	7	Retrofit TLED solutions	22-23
Product innovations	8-9	Emergency lighting inverters.	24-25
Application and Environment.	10	Flexibility of dimming inverters	26-31
Solutions for LED emergency lighting . . .	12	Fluorescent emergency ballasts.	32-35
LED terminology	13	Auxiliary applications	36-37
Emergency LED drivers	14-15	About Bodine	38



Emergency lighting

Emergency lighting is vital to life safety programs and is required in all commercial, industrial and institutional facilities. Codes and regulations establish guidelines for emergency lighting equipment. However, there may be circumstances that call for more than minimum standards. Incorporating the right combination of elements into emergency lighting design provides a higher degree of safety. The best emergency lighting system is carefully planned for a specific building and its occupants. As a part of this planning process, it is important to consider a variety of factors. Details of the interior, including ceiling height, wall colors and textures; number and placement of exits; the intended use of a building; and the expected number of occupants must be considered when selecting and applying emergency lighting. This catalog provides an overview of available Bodine technologies that provide code-compliant solutions for your emergency lighting applications.

Emergency lighting is code required

Emergency lighting is a vital part of a facility's life safety program. Local, state and national building codes, such as the NFPA® Life Safety Code® and National Electrical Code®, require reliable and sufficient emergency illumination for commercial, industrial and institutional buildings in the United States. When normal power fails for any reason, emergency lighting provides critical illumination. It helps to guide building occupants along the path of egress to the nearest exit.

Bodine emergency lighting provides instant backup

Innovative Bodine emergency lighting products provide instant backup lighting whenever normal power fails. Bodine emergency LED drivers, fluorescent emergency ballasts and emergency lighting inverters deliver 90 minutes of battery-supplied power.

Complements original designs

Bodine emergency lighting products complement original lighting designs. Because they can be installed inconspicuously inside, on top of, near or remote from the fixture – depending on factors such as fixture, emergency lighting product and product model – they do not detract from fixture or interior design. Bodine emergency lighting is emergency lighting you'll never see until you need it.

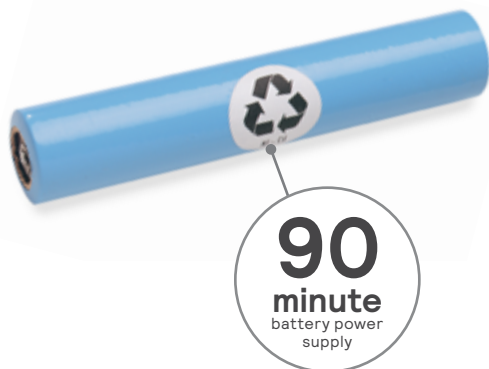

When normal power fails, Bodine emergency lighting products sense the loss and immediately switch into emergency mode.





One luminaire two sources of power

Looks like normal lighting

Bodine emergency lighting products use the same light source for normal and emergency lighting. As a result, emergency lighting appears similar to lighting under normal conditions.

May reduce the risk of tampering

Installed Bodine units are generally less visible than other forms of emergency lighting, such as wall packs. Their inconspicuous placement may help reduce their visibility to potential vandals.

Application

Bodine provides emergency lighting products for a wide variety of applications, including indoor, outdoor, damp, cold temperature and hazardous locations. Some products offer a self-testing feature that is an automatic solution for code-compliant testing of emergency lighting.

Operation

When normal power fails, Bodine emergency lighting products sense the loss and immediately switch into emergency mode. This means the emergency lighting unit immediately begins supplying supplemental power to support emergency lighting operation for a minimum of 90 minutes. When normal power is restored, the emergency lighting unit returns to the charging mode.

NRTL Compliance

Bodine emergency lighting products are tested by Underwriters' Laboratories (UL) in accordance with standards set forth in UL 924, "Emergency Lighting and Power Equipment," and/or by other nationally recognized testing laboratories.

Life safety code

AC power failures occur for a variety of reasons. Storms and other extreme weather conditions can affect AC power.

Vehicular accidents, fires or equipment failure can also result in power outages. When this happens, liability concerns are inevitable. Serious accidents or mishaps could occur when occupants are left in total darkness during a power failure. In such instances, the first area of inquiry is often, “Did this building meet code?”.

Laws, codes and regulations

Although state and local building codes vary, most are based upon:

1. National Electrical Code®, NFPA 70®, Article 700
2. Life Safety Code®, NFPA 101®, Section 7.9;
3. Occupational Safety & Health Act (OSHA) regulations.

These codes provide complete information about emergency lighting requirements. However, a basic starting point is provided in the LSC 7.9.2.1 - 7.9.2.1.3 (2015), which states:

- 7.9.2.1** Emergency illumination shall be provided for a minimum of 1 ½ hours in the event of failure of normal lighting.
- 7.9.2.1.1** Emergency lighting facilities shall be arranged to provide initial illumination that is not less than an average of 1 ft-candle (10.8 lux) and, at any point, not less than 0.1 ft-candle (1.1 lux), measured along the path of egress at floor level.
- 7.9.2.1.2** Illumination levels shall be permitted to decline to not less than an average of 0.6 ft-candle (6.5 lux) and, at any point, not less than 0.06 ft-candle (0.65 lux) at the end of 1 ½ hours.
- 7.9.2.1.3** The maximum-to-minimum illumination shall not exceed a ration of 40 to 1.

It is important to remember that codes generally set minimum standards. Specifiers, building owners, facility management or municipalities may choose to go beyond minimums in their effort to keep people and property safe.

Maintenance and testing

Codes mandate periodic monitoring of emergency lighting equipment once it is installed. Emergency operation must be tested at 30-day intervals for a minimum of 30 seconds, and, for battery-powered systems, a 90-minute discharge test must be conducted once a year. Additionally, the NFPA requires that records be kept as proof of maintenance.



Specifiers, building owners, or facility management may choose to go beyond minimums in their effort to keep people and property safe.



“Did this building meet code?”

Serious accidents or mishaps could occur when occupants are left in total darkness during a power failure. In such instances, the first area of inquiry is often: “**Did this building meet code?**”



Code-required testing

Functional testing shall be conducted monthly, with a minimum of 3 weeks and a maximum of 5 weeks between tests, for not less than 30 seconds, except as otherwise permitted by 7.9.3.1.1(2).

(7.9.3.1.1(1), NFPA® Life Safety Code® 2015)



7.9.3 Periodic Testing of Emergency Lighting Equipment.

7.9.3.1.1 Testing of required emergency lighting systems shall be permitted to be conducted as follows:

- (1) Functional testing shall be conducted monthly, with a minimum of 3 weeks and a maximum of 5 weeks between tests, for not less than 30 seconds, except as otherwise permitted by 7.9.3.1.1(2).
- (2) The test interval shall be permitted to be extended beyond 30 days with the approval of the authority having jurisdiction.
- (3) Functional testing shall be conducted annually for a minimum of 1½ hours if the emergency lighting system is battery powered.
- (4) The emergency lighting equipment shall be fully operational for the duration of the tests required by 7.9.3.1.1(1) and (3).
- (5) Written records of visual inspections and tests shall be kept by the owner for inspection by the authority having jurisdiction.

7.9.3.1.2 Testing of required emergency lighting systems shall be permitted to be conducted as follows:

- (1) Self-testing/self-diagnostic battery-operated emergency lighting equipment shall be provided.
- (2) Not less than once every 30 days, self-testing/self-diagnostic battery-operated emergency lighting equipment shall automatically perform a test with a 30 second minimum duration and a diagnostic routine.
- (3) Self-testing/self-diagnostic battery-operated emergency lighting equipment shall indicate failures by a status indicator.
- (4) A visual inspection shall be performed at intervals not exceeding 30 days.
- (5) Functional testing shall be annually conducted for a min. of 1½ hours.
- (6) Self-testing/self-diagnostic battery-operated emergency lighting equipment shall be fully operational for the duration of the 1½ hour test.
- (7) Written records of visual inspections and tests shall be kept by the owner for inspection by the authority having jurisdiction.

(NFPA® Life Safety Code® 2015)

Innovations for emergency lighting applications

Bodine emergency lighting products are designed to fit today's sophisticated lighting technologies and applications.

A variety of products are available for applications that require code-compliant emergency lighting. Whether your design requires unit equipment for new or existing LED fixtures, fluorescent fixtures or devices for use in conjunction with generators, Bodine offers an emergency lighting solution for your application. Product features such as self-testing and suitability for extreme temperature environments and hazardous locations are available on selected models to fit the specified applications.



Emergency LED drivers

Bodine emergency LED drivers work in conjunction with LED fixtures to serve as code-compliant emergency lighting sources. The line includes drivers for indoor, outdoor, damp, cold temperatures, steplights, downlights, Class 2 installations and more. Optional features are available, and the emergency drivers can be installed inside, on top of, or remotely from the fixture, depending on the product, fixture and application. Most models are UL Listed.



Emergency inverters

Bodine emergency lighting inverters are sinusoidal (sine wave) units that support LED, TLED or fluorescent fixtures during loss of normal AC power. The inverters sense the loss of power and immediately begin supplying emergency power to the designated lighting load. Bodine inverters support emergency lighting for a code-required 90 minutes. Models are Listed and comply with UL 924 emergency lighting standards.



Fluorescent emergency ballasts

Bodine fluorescent emergency ballasts work with linear or compact lamp fluorescent fixtures. The FEB line includes products designed for indoor, outdoor, damp and cold temperature applications. They can be installed inside, on top of or remotely from the fixture, depending on factors such as model, fixture and application. Optional features such as self-testing capabilities and suitability for cold or hazardous locations are available on some units. Both UL Listed and UL Recognized models are included in the fluorescent line.



Auxiliary emergency devices

Bodine offers distinct products created to work with generators. These energy-saving devices sense the loss of normal power and, in response, switch the lighting load to a generator or inverter-fed circuit, supplying emergency lighting regardless of local light switch position. This means emergency lighting is no longer dependent on expensive night lighting. Normal lighting can be switched off at the end of the day or whenever it's not needed without jeopardizing emergency lighting operation.

Application and environment

Bodine delivers solutions with product features that address a broad range of applications.

Various environmental and application conditions must be considered when installing or specifying emergency lighting. A number of factors, including the intended use of a building or structure, the occupants, the layout and the environment (e.g., temperature, dry/damp), will help determine the proper emergency lighting equipment needed to meet code requirements.

Large installations may create a challenge in terms of meeting the required testing and maintenance schedules for life safety equipment. Self-testing products can help building maintenance personnel overcome that challenge.

Schools, hospitals and assisted-living facilities may require higher levels of emergency illumination or longer runtimes than a typical office building. Structures such as concert forums, designed for a large number of occupants that are likely unfamiliar with the layout, may also benefit from increased light levels and extended runtimes. Interior characteristics such as ceiling height, corridors, wall placement and color will play a role in determining the amount of illumination needed and the placement of emergency lighting in the facility.

Outdoor egress is an important area of emergency lighting and presents challenges to emergency lighting equipment. Covered walkways and parking garages, for example, are often subject to extreme temperatures, as well as damp location conditions. Facilities such as refineries and cold storage require emergency lighting equipment suitable to their specialized demands.

Bodine emergency lighting products are designed to help you meet code requirements (e.g., NFPA® Life Safety Code®) with these factors in mind.



Self-testing products

Bodine self-testing products automatically test emergency lighting operation for 30 seconds every 30 days and for 90 minutes annually to meet life safety codes. Self-testing products help reduce costs involved in code-compliant testing and are ideal for fixtures in hard-to-reach and high-traffic locations. Self-testing products simplify the task of testing large numbers of fixtures and provide an automatic solution for meeting code requirements.



Extreme temperature products

The Bodine extended-temperature product line provides code-compliant emergency lighting under challenging conditions. Extended-temperature products are designed to withstand temperatures generally ranging from -4°F to $+131^{\circ}\text{F}$ (-20°C to $+55^{\circ}\text{C}$) and are suitable for use in indoor, outdoor egress and damp locations.



Hazardous location products

Locations such as oil refineries, paint booths and textile mills are associated with potential fire and explosion hazards, including combustible gases, liquids, dust and fibers. Bodine emergency products for hazardous (classified) location fixtures are UL Component Recognized for factory installation only and are suitable for use in Class I, Division 2 type fixtures.



Emergency solutions for LED lighting

Choosing the appropriate emergency backup solution starts with the LED light source.



Emergency drivers

Emergency LED drivers are an appropriate choice for applications utilizing an LED array powered by an external AC driver. Emergency LED drivers can be installed inside, on top of or remotely from a fixture and operate one fixture during a power failure.

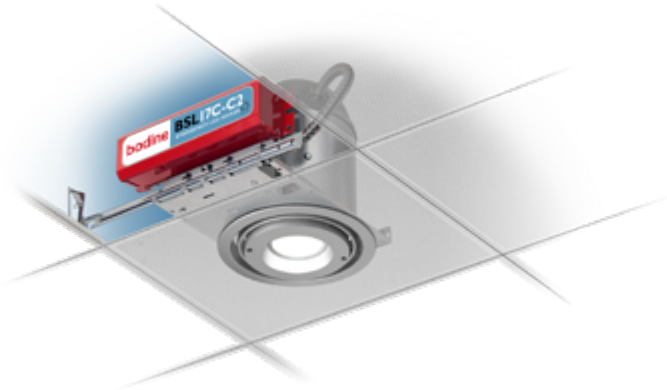

Inverters

Emergency inverters are the most flexible solutions for LED applications. They may be used in applications that utilize LED lighting driven by external drivers. They are also suited for screw-in (Edison base) lamps or linear (tubular) lamps with an integrated/internal AC driver. Inverters, depending on capacity, can operate more than one fixture during a power failure.



All inverters can be remote mounted. Please check individual products for specifics.

“As with other types of lighting, LED lighting must meet the life safety code requirements for emergency illumination to guide building occupants along the path of egress.”

LED terminology

LED: Light-emitting diode. A semiconductor device (diode) that emits visible light when electricity is applied.

LED array: A configuration of one or more (usually many more) LEDs connected to the same power source.

LED driver: A device that converts line voltage into the DC voltage and current necessary to drive the LED load.

Emergency LED driver: A device that uses electronic circuitry to convert energy stored in a battery into the DC voltage and current necessary to drive the LED load when power fades within the parameters established by life safety codes.

Integral-base LED lamp: A lamp in which the driver is built into the base. Because the lamp driver is built into the base, an emergency LED driver cannot be wired in between it and the lamp/LED/LED array. A unit with an integral base must, therefore, be driven in emergency mode by an inverter product.

TLED (tubular LED): A tubular shaped LED lamp designed to replace the lamps in fluorescent fixtures. Various types of TLED lamps are available to use depending on the type of fixture and/or power source in the application. Some TLEDs have integral drivers that operate without external drivers.



Emergency LED drivers

The emergency LED driver line allows LED fixtures to serve as code-compliant emergency lighting sources. The expanding line includes drivers designed for a variety of applications: indoor, outdoor, damp, cold temperatures, steplights, downlights, Class 2 installations and more.

When normal AC power fails, the emergency LED drivers switch into emergency mode and support LED fixtures for 90 minutes.

As with other types of lighting, LED lighting must meet life safety code requirements for emergency lighting when it is used in an emergency capacity. Therefore, LED fixtures serving as emergency lighting sources must provide 90 minutes of illumination in the event of a power failure.

When normal AC power fails, the emergency LED drivers switch into emergency mode and support LED fixtures for 90 minutes. When AC power is restored, the drivers automatically return to the charging mode.

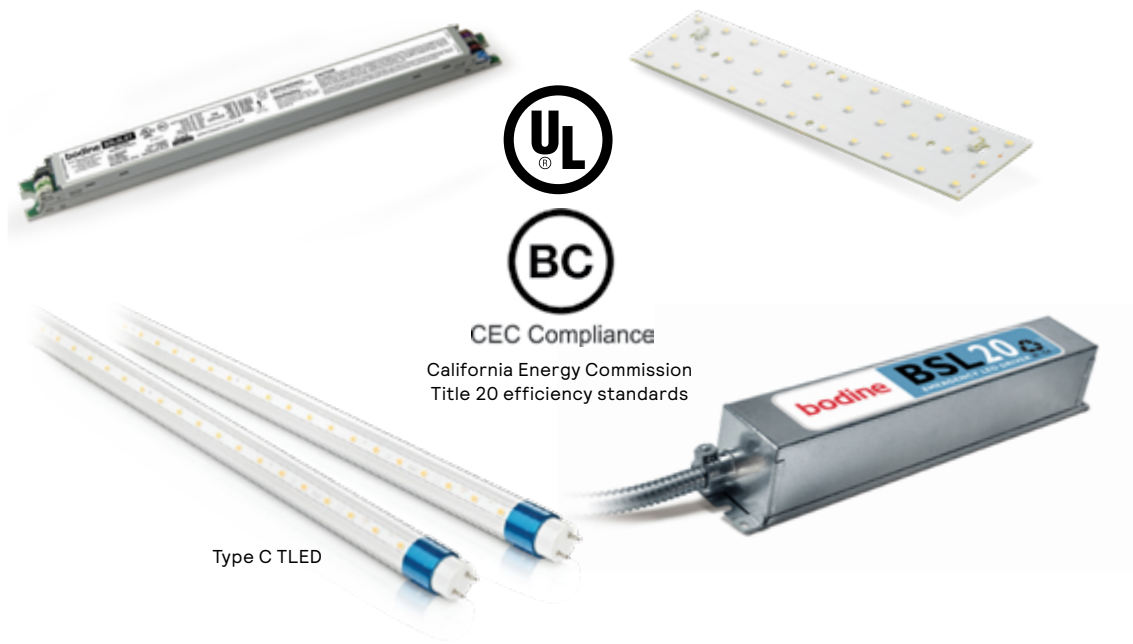



Innovative Emergency LED Drivers

Model	Class Rating	Output Voltage (VDC)	Output Power	Dimensions (L x W x H)	UL	BC	RU	Feature / Benefit
BAC40EM6	Class 2	22.5 - 54	40W AC / 6W EM	14.1" x 1.18" x 1.0" + battery				Combination AC and emergency driver SimpleSet AC output programming Separate battery design
BAC40EM10	Class 2	22.5 - 54	40W AC / 10W EM	14.1" x 1.18" x 1.0" + battery				Combination AC and emergency driver SimpleSet AC output programming Separate battery design
BSL4L	Class 2	15 - 54	4.0 W	16.7" x 1.18" x 1.0"	●	●		Compact design
BSL4SB	Class 2	15 - 50	4.0 W	6.57" x 2.25" x 1.18" + battery	●	●		Cold temps (-4° F to +131° F) Separate battery design
BSL6LST	Class 2	15 - 54	6.0 W	14.1" x 1.18" x 1.0"	●	●		Self-testing Compact design
BSL8SB	Class 2	15 - 50	8.0 W	6.57" x 2.25" x 1.18" + battery	●	●		Cold temps (-4° F to +131° F) Separate battery design
BSL10LST	Class 2	15 - 54	10.0 W	16.7" x 1.18" x 1.0"	●	●		Self-testing Compact design
BSL10 Cold-Pak	Class 2	24 - 52	14.0 W	8.97" x 3.5" x 2.9"	●			Cold temps (-4° F to +131° F)
BSL17C-C2 (conduit) BSL17-C2 (non-conduit)	Class 2	15 - 50	7.5 W	12" x 2.4" x 1.5"	●	●		Multiple mounting configurations
BSL17C-C2ST	Class 2	15 - 50	7.0 W	12" x 2.4" x 1.5"	●	●		Self-testing Multiple mounting configurations
BSL17C (conduit) BSL17 (non-conduit)	non Class 2	30 - 130	7.0 W	12" x 2.4" x 1.5"	●	●		Multiple mounting configurations
BSL20LV	Class 2	20 - 50	20.0 W	16.6" x 2.8" x 2.85"	●	●		High output Dual flex option
BSL20MV BSL20HV	non Class 2	50 - 130 125 - 200	20.0 W	16.6" x 2.8" x 2.85"	●	●		High output Dual flex option on HV model
BSL36 Cold-Pak	Class 2	15 - 52	6.0 W	9.4" x 2.6" x 1.5"	●			Cold temps (-4° F to +131° F)
BSL310 (non-conduit)	Class 2	15 - 50	10.4 W	14.5" x 2.25" x 1.18"	●	●		Polycarbonate case Selectable voltage
BSL310C (conduit) BSL310M (non-conduit)	Class 2	15 - 50	10.0 W	15.34" x 2.25" x 1.16"	●	●		Universal input Selectable voltage
BSL310C-DF (conduit)	Class 2	15 - 50	10.0 W	15.34" x 2.25" x 1.16"	●	●		Universal input Dual flex conduit on one end
BSL310LP	Class 2	15 - 52	10.0 W	22.5" x 1.18" x 1.18"	●	●		For low-profile fixtures Universal input self-test
BSL310LPST	Class 2	15 - 52	10.0 W	22.5" x 1.18" x 1.18"	●	●		For low-profile fixtures Universal input
BSL310SB	Class 2	10 - 50	10.0 W	6.57" x 2.25" x 1.18" + battery	●	●		Universal input Separate battery
BSL310HAZ	Class 2	10 - 50	10.0 W	15.34" x 2.25" x 1.16"		●	●	Suitable for hazardous locations
BSL310HAZSB	Class 2	10 - 50	10.0 W	6.2" x 2.2" x 1.2"		●	●	Suitable for hazardous locations Separate battery design
BSL718	Class 2	20 - 50	18.0 W	9.4" x 2.2" x 1.05" + battery	●	●		Normal or extreme temps (-4° F to +140° F) Separate battery design
BSL722	Class 2	28 - 33	23.1 W	9.4" x 2.2" x 1.05" + battery			●	Universal input Drives two LED arrays in parallel Separate battery design
BSL722 Cold	Class 2	28 - 33	23.1 W	9.4" x 2.2" x 1.05" + battery			●	Universal input, Cold temps (-4° F to +140° F) Drives two LED arrays in parallel Separate battery design

Some Bodine emergency driver models are designed with special features, including Self-Test for automatic code-compliance testing, Cold-Pak for extreme temperatures and Low-Profile cases for narrow or space-limited fixtures. In addition, some models are designed for hazardous location use. Please refer to our website (www.bodine.com) for more information.

Alternate models and configurations are also available for many Bodine emergency LED drivers. Additional product details can be found on the model specification sheets at www.bodine.com



Integrated technologies

A simple equation for a comprehensive solution

1 + 1 = one

UltimateOne

AC/EM LED combination driver

Bodine UltimateOne LED drivers deliver AC and emergency operation. The UltimateOne line currently includes two models – BAC40EM10 and BAC40EM6. The BAC40EM10 and BAC40EM6 are a combination of a 40W dimming LED driver with SimpleSet technology and a 10W or 6W emergency LED driver in one low-profile case. The combination drivers are supplied with a separate high-temperature nickel-cadmium battery with one simple connection point and can provide up to 10W or 6W, depending on the model, to a Class 2 LED load for 90 minutes in emergency mode. They are suitable for indoor and damp locations, are universal input units and dim to 1%.



SimpleSet wireless programming technology for LED drivers is designed to help OEMs quickly and easily program LED drivers at any time during the manufacturing, distribution or installation process. As a result, OEMs and their customers can meet orders faster and with greater confidence while reducing costs and inventory.

Features & Benefits

- Combined AC and emergency LED driver in one compact, low-profile case
- AC/EM driver compatibility is confirmed
- Separate battery for mounting flexibility
- Fewer wires to help simplify installation
- Class 2 output - UL 1310 Certified, CSA 22.2 No 223-M91 compliant
- Compatible with a variety of LED strip manufacturers
- SimpleSet programming for AC operation
- 0 - 10V dimming to 1%
- RoHS compliant



SimpleSet



Wireless programming benefits

Using SimpleSet technology, OEMs will be able to quickly and easily program the driver's maximum output current and its dimming profiles without it being powered or wired. This speed and flexibility will allow OEMs and their customers to set and reset parameters as needed.

UltimateOne Model	Dimensions (L x W x H)	Battery Dimensions	Emergency Initial Output Power (W)	Emergency Illumination Time
BAC40EM10	14.1" x 1.18" x 1.0"	1" dia. x 14.8"L	10 W	90 minutes
BAC40EM6	14.1" x 1.18" x 1.0"	1" dia. x 14.1"L	6 W	90 minutes

See individual specification sheets for detailed technical information.



Speed

Program fixtures faster without requiring complex and time-consuming wiring mechanics or powering up drivers.



Flexibility

Program at any stage in the manufacturing process, before or after installation in the fixture or in the field.



Reduced costs

Meet a diverse set of customer needs without managing different driver SKUs or over-extending SKUs.



Simplicity

Deploy anywhere in the assembly process without complex training - intuitive for anyone, regardless of experience.



Security

Protect programmed values with password protection.



Selecting emergency LED drivers

Several factors should be considered when selecting an emergency LED driver, including the environment and application, the total array voltage and the output required to meet the code requirements for emergency lighting. Refer to the following pages to help select the appropriate emergency LED driver for your application.

Start

with these easy steps to select the proper emergency LED driver for your fixture.

Use these simple steps and the chart on the following pages to select the best solution for your emergency LED lighting application.

Specification Guide

Identify the fixture being utilized and record the specification data:

1. Make and model
2. Load voltage of LED array(s) _____ Vf
3. LED load rated power _____ Watts
4. Output current of the AC LED driver into LED load as applied _____ Amps

Load Voltage

Identify the LED's load voltage (Vf)

This is the total forward voltage (Vf or stacked voltage) of the luminaire's LED array(s). This information can be found on the product spec sheet, labeling, or on the LED array(s).



Locate your fixture's (LED array) total load voltage at the top of the chart - **Approximate Load Voltage** - and find the available EM LED drivers for this voltage in the selected column. The type of luminaire and application/location will help determine which EM driver to use.

Wattage (W)

Verify maximum power of LED load

The LED load's rated power must be greater than or equal to the output of the selected EM LED driver.

LED load (W) ≥ to EM driver power output (W)

Designated as **Power (W)** for each EM LED driver on the chart. Use the chart to ensure the LED load's rated power (W) is greater than or equal to the EM Driver power output (W).

Current (from AC driver)

Maximum current into EM driver

See the emergency LED current limit in the column Max. AC Driver Output on the chart.



The maximum current from the AC driver must be less than or equal to the current the EM driver can accept.*

Lumens

Verify emergency lumen output

Find the approximate emergency lumen output for each EM driver on the chart or calculate.

Lumens = lm/w _____ X _____ (W)

Emergency illumination (lumens) can be calculated by multiplying the efficacy of the LED load (measured in lm/w) by the output power of the emergency driver (W).



* Use the chart to find the maximum AC Driver Output to confirm the maximum acceptable current for each EM driver.

Approximate Load Voltage (LED Array Vf)

Emergency LED Driver	Class Rating	Max. AC Driver Output (A)	Specs	Approximate Load Voltage (LED Array Vf)										
				12V	15V	18V	20V	24V	28V	30V	33V	36V	39V	
BSL6LST Self-testing	Class 2	5.0 A	Power (W) ~ Lumens		6.4 780	6.4 780	6.4 780	6.4 780	6.4 780	6.4 780	6.4 780	6.4 780	6.4 780	
BSL10LST Self-testing	Class 2	5.0 A	Power (W) ~ Lumens		10.5 1300	10.5 1300	10.5 1300	10.5 1300	10.5 1300	10.5 1300	10.5 1300	10.5 1300	10.5 1300	
BSL17C-C2 BSL17-C2	Class 2	3.0 A	Power (W) ~ Lumens		7.5 940	7.5 940	7.5 950	7.5 950	7.5 950	7.5 950	7.5 950	7.5 940	7.5 940	
BSL17C-C2ST Self-testing	Class 2	3.0 A	Power (W) ~ Lumens		7.5 940	7.5 940	7.5 950	7.5 950	7.5 950	7.5 950	7.5 950	7.5 940	7.5 940	
BSL310 Red poly case	Class 2	3.0 A	Power (W) ~ Lumens		10.5 1290	10.5 1340	10.5 1370	10.5 1350	10.5 1350	10.5 1340	10.5 1340	10.5 1330	10.5 1370	
BSL310M (C or C-DF)	Class 2	3.0 A	Power (W) ~ Lumens		10.5 1290	10.5 1340	10.5 1370	10.5 1350	10.5 1350	10.5 1340	10.5 1340	10.5 1330	10.5 1370	
BSL310LP BSL310LPST	Class 2	2.5 A	Power (W) ~ Lumens		10.5 1290	10.5 1340	10.5 1370	10.5 1350	10.5 1350	10.5 1340	10.5 1340	10.5 1330	10.5 1370	
BSL310SB Small case, Separate battery	Class 2	3.0 A	Power (W) ~ Lumens		10.5 1290	10.5 1340	10.5 1370	10.5 1350	10.5 1350	10.5 1340	10.5 1340	10.5 1330	10.5 1370	
BSL20LV	Class 2	5.0 A	Power (W) ~ Lumens				21 2770	21 2780	21 2800	21 2800	21 2810	21 2800	21 2800	
BSL36 Cold-Pak -20°C to 55°C	Class 2	2.5 A	Power (W) ~ Lumens		6.0 780	6.0 780	6.0 780	6.0 780	6.0 780	6.0 780	6.0 780	6.0 780	6.0 780	
BSL10 Cold-Pak -20°C to 55°C	Class 2	1.25 A	Power (W) ~ Lumens					15 1900	15 1900	15 1900	15 1900	15 1890	15 1890	
BSL4L	Class 2	3.0 A	Power (W) ~ Lumens		4.0 520	4.0 520	4.0 520	4.0 520	4.0 520	4.0 520	4.0 520	4.0 520	4.0 520	
BSL722+ BSL722 Cold-Pak+	Class 2	NA	Power (W) ~ Lumens						20.2 2630	22.2 2890	23.1 3000			
BSL718 (Ext. Temps) -20°C to 60°C	Class 2	5.0 A	Power (W) ~ Lumens				18.0 2340	18.0 2340	18.0 2340	18.0 2340	18.0 2340	18.0 2340	18.0 2340	
BSL4SB Small case, Separate battery	Class 2	3.0 A	Power (W) ~ Lumens		4.0 520	4.0 520	4.0 520	4.0 520	4.0 520	4.0 520	4.0 520	4.0 520	4.0 520	
BSL8SB Small case, Separate battery	Class 2	3.0 A	Power (W) ~ Lumens		8.0 1040	8.0 1040	8.0 1040	8.0 1040	8.0 1040	8.0 1040	8.0 1040	8.0 1040	8.0 1040	
BSL310HAZ+ Suitable for Class I, Div. 2 fixtures	Class 2	3.0 A	Power (W) ~ Lumens		9.9 1290	10.3 1340	10.5 1370	10.4 1350	10.4 1350	10.3 1340	10.3 1340	10.2 1330	10.5 1370	
BSL310HAZSB Suitable for Class I, Div. 2 fixtures Separate battery design	Class 2	3.0 A	Power (W) ~ Lumens		9.9 1290	10.3 1340	10.5 1370	10.4 1350	10.4 1350	10.3 1340	10.3 1340	10.2 1330	10.5 1370	

+ UL Recognized products are for factory installation only.

Approximate Load Voltage (LED Array Vf)

Emergency LED Driver	Class Rating	Max. AC Driver Output (A)	Specs	Approximate Load Voltage (LED Array Vf)									
				45V	48V	50V	54V	60V	66V	72V	78V	84V	90V
BSL17 BSL17C	non Class 2	3.0 A	Power (W) ~ Lumens	7.3 950	7.3 950	7.4 960	7.4 960	7.4 960	7.4 960	7.4 960	7.4 960	7.4 960	7.4 960
BSL20MV	non Class 2	2.0 A	Power (W) ~ Lumens			21.1 2740	21.2 2760	21.2 2760	21.3 2770	21.4 2780	21.4 2780	21.4 2780	21.5 2800

Approximate Load Voltage (LED Array Vf)

Emergency LED Driver	Class Rating	Max. AC Driver Output (A)	Specs	Approximate Load Voltage (LED Array Vf)									
				125V	129V	132V	138V	144V	150V	156V	162V	168V	174V
BSL20HV	non Class 2	2.0 A	Power (W) ~ Lumens	21.7 2820	21.7 2820	21.8 2830	21.8 2830	21.7 2820	21.8 2830	21.7 2820	21.8 2830	21.9 2850	21.9 2850



Lumens in emergency mode = Lumens per watt of fixture **X** Output power of chosen EM driver

_____ = _____ (Lm/W) **X** _____ (W)

Note: Lumens indicated on this chart are calculated based on a typical LED fixture lumen output of **130 lumens per Watt load**. In many cases the lumen output in emergency mode can be greater or less due to the actual efficacy of the LED load being utilized. Use the formula above to calculate actual lumens in emergency mode.

For more information, contact Bodine at: <email> or 1-800-223-5728.

42V	45V	48V	50V	52V	54V	60V
6.4 780	6.4 780	6.4 780	6.4 780	6.4 780		
10.5 1300	10.5 1300	10.5 1300	10.5 1300	10.5 1300		
7.5 920	7.5 940	7.5 920	7.5 920			
7.5 920	7.5 940	7.5 920	7.5 920			
10.5 1350	10.5 1350	10.5 1330	10.5 1330			
10.5 1350	10.5 1350	10.5 1330	10.5 1330			
10.5 1350	10.5 1350	10.5 1330	10.5 1330	10.5 1310		
10.5 1350	10.5 1350	10.5 1330	10.5 1330			
21 2780	21 2780	21 2780	21 2770			
6.0 780	6.0 780	6.0 780	6.0 780	6.0 780		
15 1860	15 1910	15 1900	15 1890	15 1870		
4.0 520	4.0 520	4.0 520	4.0 520	4.0 520	4.0 520	
18.0 2340	18.0 2340	18.0 2340	18.0 2340			
4.0 520	4.0 520	4.0 520	4.0 520			
8.0 1040	8.0 1040	8.0 1040	8.0 1040			
10.4 1350	10.4 1350	10.2 1330	10.2 1330			
10.4 1350	10.4 1350	10.2 1330	10.2 1330			

Listing*		
UL	BC	RU
•	•	
•	•	
•	•	
•	•	
•	•	
•	•	
•	•	
•	•	
•	•	
•	•	
•		•
•	•	
•	•	
•	•	
	•	•
	•	•

Typical Fixture Type	Location/Application
Linear strip, Slim/Low-profile, Recessed, Surface, Pendant	Indoor, Damp
Linear strip, Slim/Low-profile, Recessed, Surface, Pendant	Indoor, Damp
Recessed downlight, Surface, Pendant	Indoor, Damp
Recessed downlight, Surface, Pendant	Indoor, Damp
Linear strip, Recessed, Surface, Pendant	Indoor, Damp
Linear strip, Recessed, Surface, Pendant	Indoor, Damp
Linear strip, Slim/Low-profile, Recessed, Surface, Pendant	Indoor, Damp
Linear strip, Slim/Low-profile, Recessed, Surface, Pendant	Indoor, Damp
High output / High bay, Linear, Surface	Indoor, Damp
Recessed downlight, Surface, Bollards	Indoor, Damp, Covered exteriors, Extreme temperatures
Recessed downlight, Surface, Bollards	Indoor, Damp, Covered exteriors, Extreme temperatures
Linear strip, Slim/Low-profile, Recessed, Surface, Pendant	Indoor, Damp
Recessed downlight, Surface, Bollards	Indoor, Damp, Covered exteriors, Extreme temperatures
Recessed downlight, Surface, Bollards	Indoor, Damp, Covered exteriors, Extreme temperatures
Recessed downlight, Surface, Bollards	Indoor, Damp, Covered exteriors, Extreme temperatures
Hazardous location	Indoor, Damp, Hazardous location
Hazardous location	Indoor, Damp, Hazardous location

96V	102V	108V	114V	120V	126V	130V
7.4 960	7.4 960	7.4 960	7.4 960	7.4 960	7.3 950	7.3 950
21.5 2800	21.4 2780	21.5 2800	21.5 2800	21.4 2780	21.5 2800	21.5 2800

Listing*		
UL	BC	RU
•	•	
•	•	

Typical Fixture Type	Location/Application
Recessed downlight, Surface, Pendant	Indoor, Damp
High output / High bay, Linear, Surface	Indoor, Damp

180V	186V	192V	198V	200V	205V	210V
21.9 2850	21.9 2850	21.9 2850	21.9 2850	21.9 2850		

Listing*		
UL	BC	RU
•	•	

Typical Fixture Type	Location/Application
High output / High bay, Linear, Surface	Indoor, Damp



UL Listed for factory or field installation.



Compliant with California Energy Commission (CEC) Title 20 requirements for battery chargers.



UL Component Recognized for factory installation only.

* Check individual product specification sheets for Listing details regarding the U.S. and Canada and for other product information.

Retrofit TLED solutions

Some TLED retrofit lamps have internal drivers that can accept AC input through the original fluorescent ballast or through connection to line voltage.

These TLED replacement lamps have internal drivers that convert AC to DC in order to power the LED array. When emergency lighting is required in these fixtures, an emergency ballast or emergency inverter with AC output may be used. See types A and B for more information.

If the TLED replacement lamps do not have internal drivers, an AC LED driver with DC output must be used to replace the fluorescent ballast. Likewise, an emergency driver that provides DC output must be used to drive the TLED lamps when normal power fails. See Type C for more information.



Certified electricians or qualified contractors should be used to convert LED retrofit fixtures into emergency lighting fixtures.

Type A: TLED replacement lamps powered by the original fluorescent ballast and lamp sockets. The select TLED tubes have internal drivers to convert AC input to DC for the LED array.

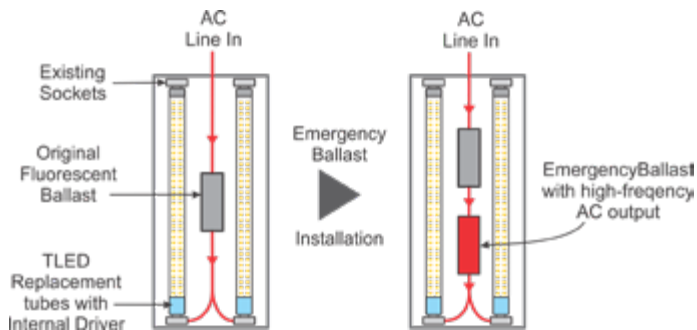

Type A emergency application uses a fluorescent emergency ballast with high-frequency AC output to power the TLED lamps during normal AC power failures.

Type B: The original fluorescent ballast is removed, and the TLED lamps are connected to line voltage. The TLED tubes have internal drivers to accept AC input.

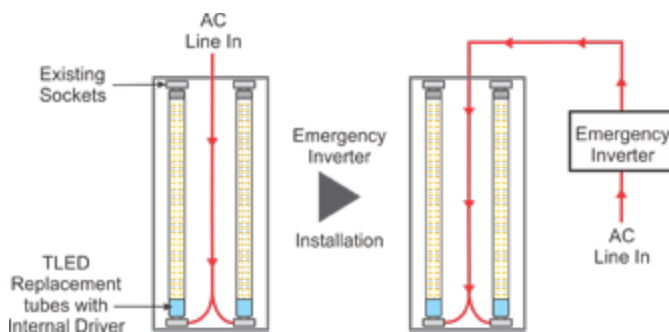

Type B emergency application uses an auxiliary emergency inverter with battery-powered AC output. Lighting controls, such as switches or dimmers, are unaffected by the inverter.

Type C: The original fluorescent ballast is replaced with an AC LED driver with DC output. The TLED tubes do not have internal drivers.

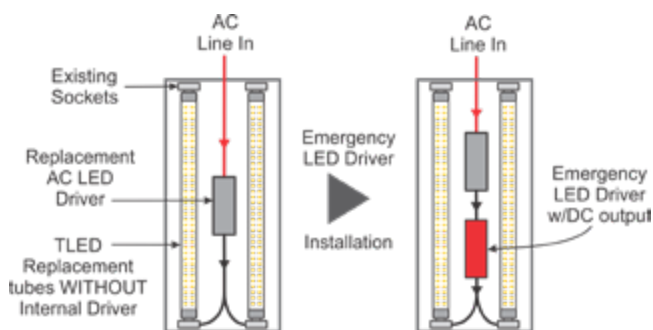

Type C emergency application uses an emergency LED driver with battery-powered DC output to drive the TLED lamps during normal AC power failures.

Note: Any of the types illustrated may use an inverter as the emergency lighting source.

Inverters for emergency lighting applications

When an emergency LED driver cannot be used, line voltage inverters may be the best solution.

Bodine emergency lighting inverters are sinusoidal (sine wave) units that support LED, TLED and fluorescent fixtures during loss of normal AC power. The inverters sense the loss and immediately begin supplying emergency power to the designated lighting load. Bodine emergency inverters support emergency lighting for 90 minutes, in accordance with code-established runtime requirements.*

Emergency lighting inverters are an excellent choice for use with multiple fixtures and in cases where emergency LED drivers cannot be used, such as with integral-base lamps. They also offer the advantage of long-distance remote installation.

Bodine emergency lighting inverters are UL Listed for field installation.

* See, for example, the NFPA® 101® Life Safety Code®.

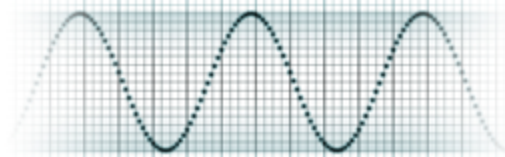

A key feature of Bodine emergency lighting inverters is sinusoidal output. Sinusoidal output is especially important for LED applications and is characterized by low harmonic distortion and by clean power similar to that produced by utility-supplied electricity.

All inverters can be remote mounted. Please check individual products for specifics.



Bodine emergency inverters comply with UL 924 emergency lighting standards.

Bodine emergency inverters are compatible with LED, TLED, fluorescent and incandescent lighting and are Listed for field installation.

up to
10VA
emergency
operation

Provides auto-dimming
of connecting lighting



ELI-S-10

- UL Listed for U.S. and Canada - UL 924 compliant
- Provides up to 10VA in emergency mode - 90 minutes
- Small form factor
- LED friendly sinusoidal output
- Dimming compatible with 10VA maximum
- Ideally compatible with single and multi-channel LED dimming drivers
- Remote installation up to 250 feet

up to
25VA
emergency
operation



ELI-S-20

- UL Listed for U.S. and Canada - UL 924 compliant
- Provides up to 25VA in emergency mode - 90 minutes
- LED friendly sinusoidal output
- Operates fixtures at full brightness in emergency mode
- Ideal for but not limited to screw-base LED lamps
- Auto-select input voltage to help reduce wiring errors
- Fused output load connections
- Remote installation up to 250 feet

up to
100VA
emergency
operation

Provides auto-dimming
of connecting lighting



ELI-S-100

- UL Listed for U.S. and Canada - UL 924 compliant
- Provides up to 100VA in emergency mode - 90 minutes
- LED friendly sinusoidal output
- Dimming compatible with 0-10V systems
- Ideal for multiple fixture operation
- Compatible with 120 or 277 VAC, automatically selected
- Fused output load connectors
- Remote installation up to 250 feet

up to
250VA
emergency
operation

Provides auto-dimming
of connecting lighting



ELI-S-250

- UL Listed for U.S. and Canada - UL 924 compliant
- Auto dimming of connected lighting with industry standard 0-10Vdc interface
- Dimmable lighting loads, input power 800VA max during normal operation
- Provides up to 250VA in emergency mode - 90 minutes
- LED friendly sinusoidal output
- Ideal for multiple fixture operation
- Remote installation up to 1,000 feet

up to
400VA
emergency
operation



ELI-S-400

- ETL Listed for U.S. - UL 924 compliant
- Provides up to 400VA in emergency mode - 90 minutes
- LED friendly sinusoidal output
- Ideal for multiple fixture operation
- Remote installation up to 1,000 feet

Check our website at www.bodine.com for more information, instructions and detailed product specifications.

Application flexibility with dimming inverters

Dimming capabilities offer options in emergency operation.

Dimming is another important Bodine inverter feature and is intended for LED applications operating in emergency mode. Dimming delivers cost savings, flexibility and control. Currently, the ELI-S-10, ELI-S-100 and ELI-S-250 support dimming functionality. One inverter can operate a string of fixtures or allow a higher power fixture to dim.



ELI-S-100 inverter

with dimming control output

The ELI-S-100 allows a high power fixture to operate at a dimmed (100VA maximum) emergency-mode level. This eliminates reliance on a high power inverter to run the fixture. Alternately, ELI-S-100 allows a string of multiple fixtures to be driven in emergency mode at a combined 100VA maximum. For example, 10 40W LED fixtures may be connected to one ELI-S-100 and dimmed for emergency operation to 20% of normal power, with each LED fixture supplying 8VA of output power ($8VA \times 10 = 80VA$)*

The ELI-S-100 provides a dimming control output of 2-10 volts, and the emergency-mode dimming voltage is field-settable in five steps to provide nominally 20%, 40%, 60%, 80% or 100%. The dimming feature requires a dimming AC driver.

The ELI-S-100 provides emergency output power of 100VA maximum and supports the lighting load for a minimum of 90 minutes. While the ELI-S-100 works with fluorescent, TLED and LED lighting, it offers two important features for LED applications: dimming capabilities and sinusoidal output.

Example: Ten 40W fixtures dimmed to 8VA in emergency mode.

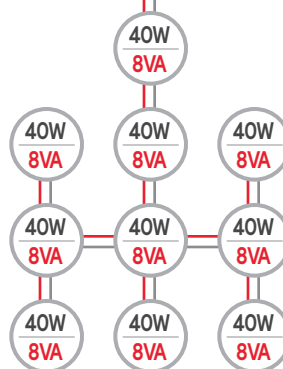

Note: dimming drivers are less efficient at reduced power. This inefficiency must be accounted for in the design.

Benefits

- Dimming compatible with 0-10V systems
- Works with LED, TLED and fluorescent fixtures
- Supplies 90 minutes of emergency illumination
- May be connected to one or more fixtures
- LED friendly sinusoidal (sine) waveform output
- Compatible with 22W TLED linear LED lamps and most manufacturers' lamps
- Suitable for indoor dry and damp locations
- Features fused output load connections
- Compatible with 120V or 266V
- Dimensions: 12.56" x 9.81" x 4.67"
- Remote mounting distance of 250 feet max.

ELI-S-100's sinusoidal output and dimming feature delivers cost-savings, flexibility and control in LED applications.



Dimming system schematic

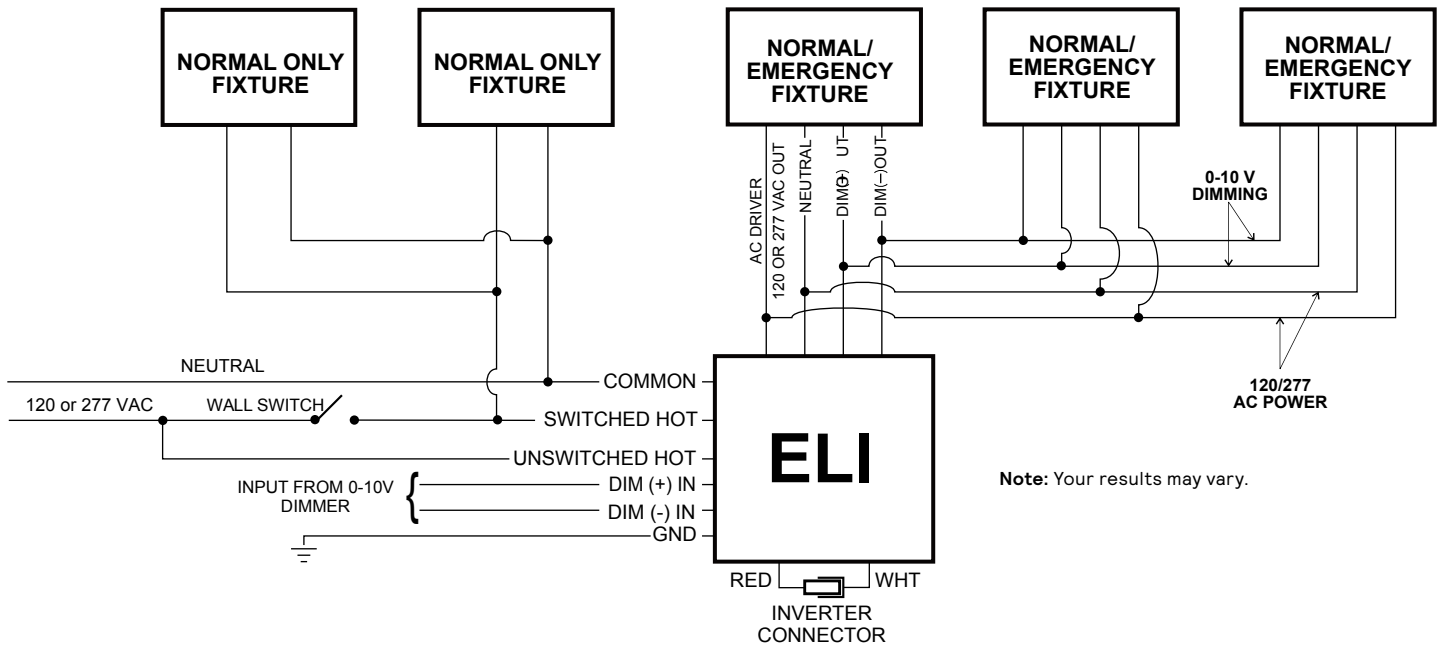

ELI-S-250 inverter

with auto-sensing dimming control output

The ELI-S-250 features an auto-sensing dimming control output with an industry standard 0-10Vdc. This automatic dimming capability allows a group of multiple luminaires to be driven in emergency mode at a combined 250VA maximum input power.* The ELI-S-250 is programmed to sense and calculate the necessary output needed to illuminate the connected fixtures, without the use of pre-set dip switches. For example, fifteen 40W (input) LED fixtures may be connected to one ELI-S-250 and automatically dimmed for emergency operation to 40% of normal power input, with each LED fixture supplying approximately 16VA of output power. The emergency mode output dimming voltage is automatically controlled by the ELI-S-250 electronic circuitry to maintain 250VA output throughout the emergency event or up to 90 minutes. The 0-10Vdc room dimmer controls, where used, are passed through the ELI-S-250 during normal, non-emergency conditions so normal dimming operations are not affected.

In the event of normal AC power failure, the ELI-S-250 provides emergency power to the connected lighting luminaires for a minimum of 90 minutes. A low battery-voltage disconnect circuit protects the inverter batteries from deep-discharge damage during prolonged power outages. When power is restored the ELI-S-250 returns to normal battery-charging mode, and the batteries are fully restored within 24 hours.

Example: Fifteen 40W fixtures at 40% dim level (16VA) in emergency mode.

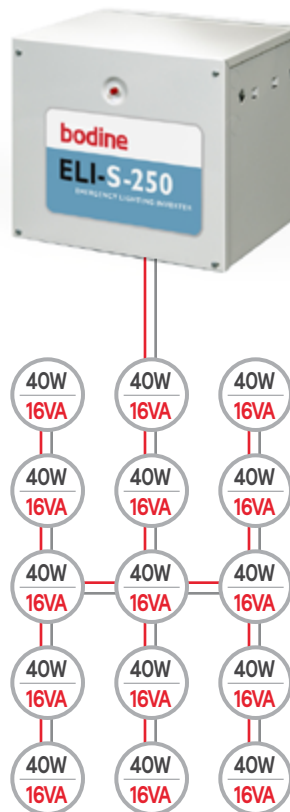

Note: Your results may vary. AC input power is always more than the LED, TLED or fluorescent output power rating. Additionally, LED drivers and fluorescent ballasts operate at a lower input-to-output power ratio in a dimmed condition than they do when operated at full brightness level.

Benefits

- Works with LED, TLED and fluorescent fixtures
- Supplies 90 minutes emergency illumination at full brightness
- Features pure sinusoidal output
- Automatic dimming of connected lighting with industry standard 0-10Vdc interface.
- Dimmable lighting loads, input power 800VA max during normal operation
- Automatic output voltage select
- Removable/replaceable electronics module
- Compatible with 22W T LED linear LED lamps
- Dimensions: 12.0" x 12.5" x 10.0"
- Remote mounting distance of 1,000 feet max.

Fluorescent emergency ballasts

Bodine fluorescent emergency ballasts (FEBs) are designed for linear and compact lamp fluorescent fixtures and select TLED retrofit applications. These emergency ballasts allow you to convert virtually any new or existing fluorescent fixture into code-compliant emergency lighting.

Linear lamp FEB

One-lamp, two-lamp and even four-lamp fixtures with T5, T8, T10 or T12 lamps can be converted with a Bodine linear FEB. The emergency ballast will run one or two lamps wired to a single ballast. Using the same light source for both normal and emergency lighting allows emergency lighting to look similar to normal lighting and can save time, labor and materials. Linear FEBs can be installed inside, on top of or remotely from the fixture, depending upon the model of emergency ballast and the fixture.

Compact lamp FEB

Bodine compact FEBs operate most 4-pin compact fluorescent lamps, including twin-tube, double twin-tube (quad), triple twin-tube, long compact and 2D. Compact FEBs allow you to easily convert new or existing fluorescent fixtures into code-compliant emergency lighting. Because the same light source is used for normal and emergency lighting, emergency lighting looks similar to normal lighting – no drastic lighting change or unwanted glare results. They can be installed on or remotely from the fixture.

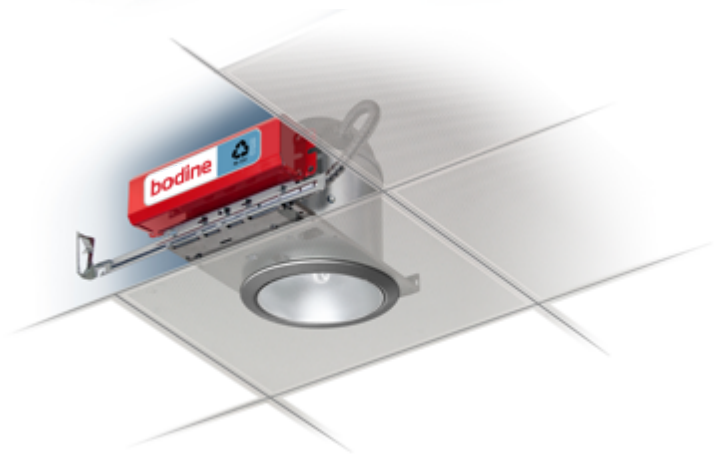
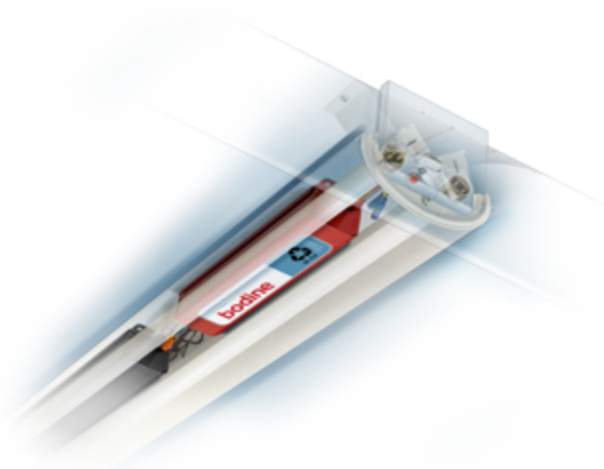

Bodine FEBs provide emergency lighting you'll never see... until you need it.



Bodine delivers solutions for fluorescent lighting with product features that address a broad range of applications. A variety of product grades and features are available to accommodate specific environments and conditions.



- High lumen output models when a high level of emergency illumination is needed
- Extended-temperature models for outdoor egress and damp locations
- Hazardous location models for Class I, Division 2 type fixtures
- Self-testing models for automatic code-compliant testing
- Low-profile models for space-limited fixtures

Bodine fluorescent emergency lighting products are designed to meet or exceed standards set by the NFPA® Life Safety Code® and the National Electrical Code®.

Product Comparison and lamp compatibility



Fluorescent emergency ballasts for linear lamp fixtures

Model	Lamps	Type of Lamps Operated	Max Lumens	Feature
B33	2 or 3	Two or three 32 W (4') T8s. For use with instant start parallel AC ballasts only	3400	Optimized for two- or three-lamp parallel emergency operation
B30	1 or 2	One 14-215 W T5 or two 17-40 W T5HO lamps (2'-4' or circline); One standard or high output T5 lamp; one 16-55 W (4-pin) 2D lamp; or one type A TLED, 18-42W CFL & 24-55 W long compact lamps	3500	Full lumen output except T5
B30HV	1 or 2	One 14-215 W (2'-8') or two 17-40 W (2'-4') T5, T8, T9, T10 or T12 lamps; One standard or high output T5 lamp; one 16-55 W (4-pin) 2D lamp; or one type A TLED, 18-42W CFL & 24-55 W long compact lamps	3500	High voltage, high bay operation; 347-480 VAC
B30ST	1 or 2	One 14-215 W (2'-8') or two 17-40 W (2'-4') T5, T8, T9, T10 or T12 lamps; One standard or high output T5 lamp; one 16-55 W (4-pin) 2D lamp; or one type A TLED, 18-42W CFL & 24-55 W long compact lamps	3500	Automatic self-testing
B50	1 or 2	One 17-215 W (2'-8') or two 17-40 W (2'-4') T5, T8, T9, T10 or T12 lamps; One 18-55 W long compact lamp; or one Type A TLED	1400	Specification grade; Universal input, AC/DC output
B50CT	1	One 13-42 W (2'-4') T5, T8 or T12 lamp; 22-55 W T5 circline; 18-55 W long compact lamp; or Type A TLED	1400	Meets CEC Title 20 efficiency standards
B50 Cold-Pak	1 or 2	One 17-215 W (2'-8') or two 17-40 W (2'-4') T8, T9, T10 or T12 lamps	1200	Extreme temperatures
B50ST	1 or 2	One 17-215 W (2'-8') or two 17-40 W (2'-4') T8, T9, T10 or T12 lamps	1400	Automatic self-testing; Universal input
B60	1 or 2	One 32-215 W (2'-8') or two 32-40 W (2'-4') T8, T9, T10 or T12 lamps. Not recommended with reduced-wattage, energy-saving T8 lamps.	700	Standard grade
B70A	1	One 32-215 W (2'-8') T8 or T12 lamp. 2-hr run time for F32T8 only. Not recommended with reduced-wattage, energy-saving T8 lamps.	700	Extended runtime
B90	1	One 32-40 W (2'-8') T8, T10 or T12 lamp. Not recommended with reduced-wattage, energy-saving T8 lamps.	600	Economical alternative
B100	1	One 32-40 W (2'-4') T8, T10 or T12 lamp. Not recommended with reduced-wattage, energy-saving T8 lamps.	450	Minimum code-compliance
LP600STU	1	One 14-54 W (2'-4') standard or high output T5; 17-55 W (2'-5') T8; 22-55 W T5 circline; 36-55 W long compact; or Type A TLED	1325	Automatic self-test; Universal input; Low-profile
LP600	1	One 14-54 W (2'-4') standard or high output T5; 17-55 W (2'-5') T8; 22-55 W T5 circline; 36-55 W long compact; or Type A TLED	1325	Damp locations; Low-profile
LP550	1	One 21-54 W (2'-4') standard or high output T5; 32-44 W (4'-5') standard or high output T8; or 36-55 W long compact. Not recommended with reduced-wattage, energy-saving T8 lamps.	700	Damp locations; Low-profile
LP500	1	One 21-54 W (2'-4') standard or high output T5 or 32 W (4') T8; Not recommended with reduced-wattage, energy-saving T8 lamps.	700	Damp locations; Low-profile
B50LP	1 or 2	One 17-215 W (2'-8') or two 17-40 W (2'-4') T8, T9, T10 or T12 lamps	1300	Damp locations; Low-profile



Fluorescent emergency ballasts for compact lamp fixtures

Model	Lamps	Type of Lamps Operated	Max Lumens	Feature
B30	1 or 2	One 18-42 W compact fluorescent lamp. Also one 14-215 W (2'-8') or two 17-40 W (2'-4') T5, T8, T9, T10 or T12 lamps; One standard or high output T5 lamps; or one 16-55W (4-pin) 2D lamp	3500	High lumen output
B30ST	1 or 2	One 18-42 W compact fluorescent lamp. Also one 14-215 W (2'-8') or two 17-40 W (2'-4') T5, T8, T9, T10 or T12 lamps; One standard or high output T5 lamps; or one 16-55W (4-pin) 2D lamp	3500	High lumen output; Self-testing
B30HV	1 or 2	One 18-42 W compact fluorescent lamp. Also one 14-215 W (2'-8') or two 17-40 W (2'-4') T5, T8, T9, T10 or T12 lamps; One standard or high output T5 lamps; or one 16-55W (4-pin) 2D lamp	3500	High voltage, high bay operation; 347-480 VAC
B50	1	13-42 W (4-pin) CFL or 18-55 W PL-L	1400	Specification grade; Universal input
B94GU	1	One 18-42 W (4-pin) twin, quad or triple twin-tube	750	Low-mercury lamps; Universal input
B4CF2P	1 or 2	One 13-42 W or two parallel 13-26 W (4-pin) twin, quad or triple twin-tube lamps; One 18-39 W or two parallel 18-27 W long compacts; or one 22-40 W T5 circline	925	Parallel operation
B4CF2PC	1 or 2	One 13-42 W or two parallel 13-26 W (4-pin) twin, quad or triple twin-tube lamps; One 18-39 W or two parallel 18-27 W long compacts; or one 22-40 W T5 circline	925	Parallel operation; with conduit
B4CF2P Cold-Pak	1 or 2	One 13-42 W or two parallel 13-26 W (4-pin) twin, quad or triple twin-tube lamps; One 18-39 W or two parallel 18-27 W long compacts; or one 22-40 W T5 circline	925	Extreme temperatures; Parallel operation

See the Bodine website, www.bodine.com, for additional products and information.

Auxiliary applications

Generators are often employed to back up the normal power supply for important systems, such as lighting. Bodine offers distinct products for generator applications.

Bodine offers innovative products created to work with generators or central inverter systems. These energy-saving devices sense the loss of normal power and, in response, switch the lighting load to a generator- or inverter-fed circuit.



Bodine offers distinct products designed to work with generators and central inverter systems: the GTD and BLCD families. These products work in conjunction with a generator or central inverter system to supply emergency lighting regardless of local light switch position. This means emergency lighting is no longer dependent on expensive night lighting. In fact, you can switch off normal lighting at the end of the day or whenever it's not needed without jeopardizing emergency lighting operation. These energy-saving devices sense the loss of normal power and, in response, switch the lighting load to a generator- or inverter-fed circuit.

GTD

The GTD operates as an emergency lighting control device and functions by transferring both the hot and the neutral on an emergency circuit fed from a 1008 transfer switch. It is designed for areas in which only one fixture may be needed for egress lighting, such as a stairwell or classroom, or in areas where multiple switches are in use. The GTD supports a lighting load up to 3A.

BLCD-20B

The BLCD-20B operates as a control or bypass device. The small, easy-to-install unit mounts directly onto a junction box and supports a lighting load up to 20A. It features auto-select to automatically select the correct voltage and offers a remote testing capability that permits it to interface with fire alarms and security panels.

Model	Function	Lighting Load
GTD	Control Device	3A max for fluorescent and LED
BLCD-20B	Control or Bypass Device	20A max for fluorescent and LED; 10A max for incandescent



GTD10DIM

The Bodine GTD10DIM operates as a switch bypass device and works in conjunction with an auxiliary generator or central inverter system to power existing LED or fluorescent fixtures for egress lighting regardless of wall switch position (ON/OFF). It can be used to override a 0-10V dimmer to full brightness. The GTD10DIM has an LED lighting load rating up to 10A. It is UL 924 Listed for the U.S. and Canada.

BLCD16DIM

The Bodine BLCD16DIM operates as a control or switch bypass device and works in conjunction with an auxiliary generator or central inverter system to power existing LED or fluorescent fixtures for egress lighting regardless of wall switch position (ON/OFF). It can be used to override a 0-10V dimmer to full brightness. The BLCD16DIM has a maximum electronic driver/ballast rating of 16A. It is UL Listed for the U.S. and Canada.

Model	Function	Lighting Load
GTD10DIM	Switch bypass device	10A max for fluorescent, incandescent, HID and LED
BLCD16DIM	Emergency lighting control unit	16A max for fluorescent, incandescent, HID and LED

GTD20A

The GTD20A automatic transfer switch/bypass device is the first-of-a-kind dual Listed emergency lighting control product for use as a branch circuit emergency lighting transfer switch (BCELT) and automatic load control relay (ALCR) or bypass device. It works with a generator or central inverter system to supply power to designated loads. The GTD20A functions as a transfer switch or bypass device and may be installed in areas where a number of fixtures are used and are controlled with a single wall switch, dimming control, occupancy sensor, photocell or any other control device used to turn these fixtures on and off. GTD20A allows multiple application and wiring options, including wiring schemes for both line and low voltage dimming. It features universal input and supports a maximum lighting load of 20A. The GTD20A is listed for use as an automatic transfer switch for emergency lighting under UL 1008 and as a bypass device under UL 924.

Model	Function	Lighting Load
GTD20A	Transfer Switch or Bypass Device	20A max for fluorescent, incandescent, HID and LED

About Bodine

Bodine's goal is to help you understand the technical and legal aspects of emergency lighting so that you can specify it with confidence. Bodine products are engineered so that, in the event of an emergency situation requiring building evacuation, emergency lighting guides occupants to the nearest path of egress, helps prevent injury en route and plays a key role in the smooth, successful passage of occupants to safety.

What we do

Bodine provides emergency solutions for the lighting industry. The company combines quality, reliability and code compliance to create products for a variety of applications. These applications include LED, fluorescent and auxiliary powered lighting. Products are sold through a nationwide network of manufacturers' representatives and electrical distributors for field installation or directly to lighting fixture manufacturers for factory installation.

Our history

Bodine, founded as The Bodine Company in 1962 by the late Richard "Dick" and Virginia "Jinnie" Bodine, sprang from humble origins. In fact, its early days were spent in a chicken coop. But Dick and Jinnie had bigger plans than their chicken coop could accommodate. In 1967 they bought the Collierville, Tennessee, property upon which Bodine still stands. The Bodines infused their company with an enduring philosophy of customer service and technical excellence. They are remembered fondly by employees and by the community they served.





