



Specification Sheet

LCN1850/05 Wireless Gateway Pro

The Wireless Gateway Pro (WG Pro) is a wireless communication hub that connects at average 150 ZigBee nodes (for example luminaires including a sensor or ZigBee Green Power (ZGP) switches) in a Connected Lighting installation. The WG Pro translates between Ethernet and ZigBee. It provides a wireless networked lighting.

LCN1850/05

Product description

The WG-Pro features an easy commissioning process during initial installation and is ready for later expansions.

The WG-Pro is powered by a 5 Vdc Class 2/SELV power adapter. The system is easily scaled up by connecting multiple WG Pros over Ethernet.

Wireless communication complies with the ZigBee Pro standard (IEEE 802.15.4, WPAN) in the 2.4 GHz frequency band. The WG-Pro must be placed within 10 m (33 ft.) from one or more of the ZigBee luminaires to form a mesh network. Communication between Philips wireless devices and the WG Pro is encrypted, as well as the communication between the WG-Pro and the devices on the Interact Office network.

The WG-Pro establishes a secure wireless ZigBee connection with at average 150 end points. The wireless connections **allows** for bidirectional control and sensor data exchange between the end points and the Interact Office network.

Features and benefits

- White enclosure, mounting bracket
- 3 LED indicators for feedback on power, connectivity, and communication
- Has unique QR code for install and commissioning
- Supports secure encrypted communication to Building Connectivity Bridge (BCB)
- Controls associated end points without access to cloud/BCB (lighting behavior)
- Lighting behavior of end devices remains operational upon failure
- Can be remotely managed, upgraded, and controlled
- The underlying lighting network will implement graceful degradation upon failures
- Secure wireless communication based on the ZigBee PRO standard (IEEE 802.15.4, WPAN) operating at 2.4GHz radio frequency (RF)
- Easily scale up the system by connecting multiple Wireless Area Controllers over Ethernet
- Functions for the WG-Pro and all connected devices can be modified with software configurable settings

Dimensions

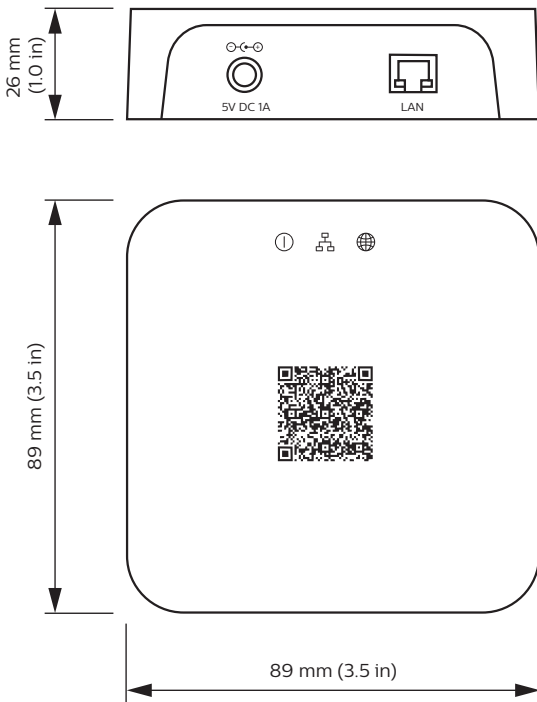

Wireless communication

The Wireless network is based on the ZigBee PRO standard (IEEE 802.15.4, WPAN) which is targeted at radio-frequency (RF) applications and operates at 2.4 GHz. The ZigBee protocol enables fully distributed peer-to-peer communication models. This means no master/ slave relationship whereby the application is divided over the devices in the network. Every device knows how it functions within the network. The result is that if one device does not function (removed or defect), the remaining devices keep functioning as intended.

The network is based on a mesh network, so devices pass on the received commands. The distance between the devices should not exceed 10 m (33 ft.). The advantage of a mesh network is the capability for self-healing routing, enabling automatic route discovery over the mesh network. ZigBee has tolerance for a large number of co-located networks due to use of multiple communication channels and CSMA-CA channel access. The commands have network security according to AES 128-bits network encryption. Other connected lighting wireless devices like the kinetically-powered ZigBee Green Power (ZGP) Switches and the Wireless Area Controller (Wireless Area Controller) use of the same protocol so they can be combined to interact in a seamless way.

The WG-Pro supports encrypted and secure wireless network communication. Third party ZigBee devices can only join the ZigBee network if their unique identifiers are explicitly enabled in the Interact Office system.

Note

Wireless signals may be subject to radio frequency interference.

Application area

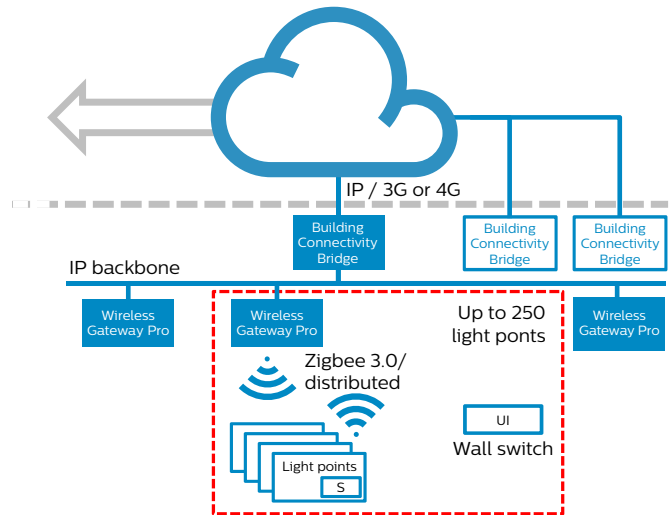

Electrical diagram

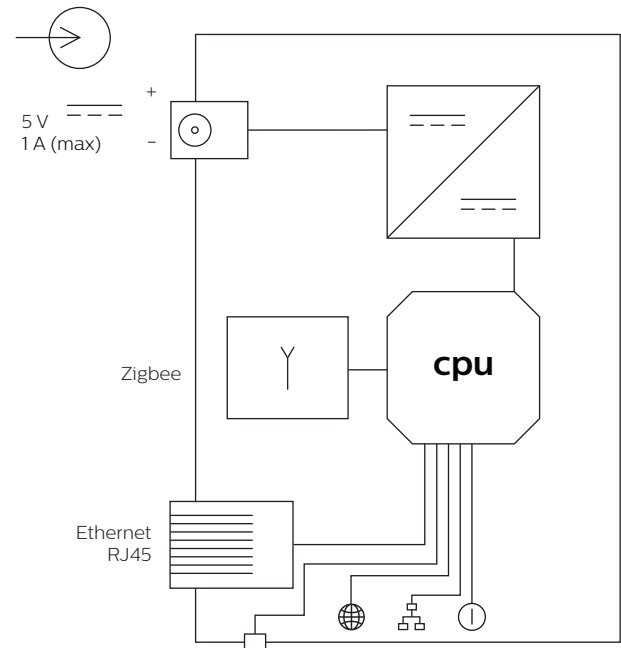

Specifications

Controller LCN1850

General Characteristics

Supply options	
Commercial grade regulated power supply	In: 100–240 Vac, 50/60 Hz Out: 5 Vdc Class 2/SELV; 1 A
Allowed supply ripple	Max. 0.5 Vpp
Power consumption	Max. 2.5 W
Communication ports	10/100BaseT Ethernet port ZigBee port
Supported Ethernet protocols	IPv6, TCP, UDP
Environmental conditions operating	
Ambient temperature range	0 to 40 °C (32 to 104 °F)
Relative humidity range	0 to 80%, non-condensing
Environmental conditions storage	
Temperature range	-40 to 80 °C (-40 to 176 °F)
Relative humidity range	10 to 90%, non-condensing
Connector type	
Supply in	1x DC plug 5.5 mm (0.2 in) 
Ethernet	RJ45
Wireless Communication	ZigBee PRO standard (IEEE 802.15.4, WPAN)
Housing	
Material	ABS
Color	Signal white (RAL9003)
Dimensions (length, width, height)	91 × 91 × 26 mm (3.6 × 3.6 × 1 in)
Weight	95 g (0.21 lb) (incl. mounting bracket)

Mounting bracket	
Material	ABS
Color	Signal white (RAL9003)
Dimensions (length, width, height)	97 × 97 × 34 mm (3.8 × 3.8 × 1.3 in)
User Controls	Reset Push Button, Status LEDs (Power, Network, Portal)

Regulatory compliance

Certifications	UL, CE, FCC, IC
Approbation (Europe)	
R&TTE RF	ETSI EN 300 328 EN 62331
R&TTE EMC	ETSI EN 301 489-1/17 EN 55022 EN 55024 EN 55032
Approbation (US & Canada)	FCC Part 15.247; 15.107; 15.109 IC RSS-247 ICES-003
Safety	EN 60950-1 (UL60950-1 & CAN/CSA-C22.2 No. 60950-1-07)
Immunity	IEC 61000-4-2, 3, 4, 5, 6, 8, 11
Reliability	IEC60068
Environmental standard	ROHS/Reach



Packing Data

Type	Dimensions	Qty/Box	Material	Weight (net)	Weight (gross)
LCN1850	110 × 80 × 110 mm (4.3 × 3.1 × 4.3 in)	1	Cardboard	0.18 kg (0.40 lb)	0.31 kg (0.68 lb)

Ordering data

EU version

Type	MOQ	Ordering number	EAN code level 1	EAN code level 3	EOC
LCN1850/05 Wireless Gateway Pro	1	9137 003 94203	8718696 698129	8718696 698136	698129 00

US version

Type	MOQ	Ordering number	UPC code level 1	UPC code level 3	Catalog code
LCN1850/05 Wireless Gateway Pro	1	9137 003 94213	046677469153	50046677469158	LCN1850/05

FCC/IC compliance statement

This device complies with part 15 of the FCC rules for the United States and Industry Canada (IC) license - exempt RSS standard(s). Operation is subject to the following two conditions: (1) This device may not cause harmful interference, and (2) this device must accept any interference received, including interference that may cause undesired operation. Any changes or modifications not expressly approved by Philips could void the user's authority to operate this equipment. This product is intended for commercial use only.

FCC Compliance Statement

This device complies with part 15 of the FCC Rules. Operation is subject to the following two conditions: (1) This device may not cause harmful interference, and (2) this device must accept any interference received, including interference that may cause undesired operation.

IC Compliance Statement

This device complies with Industry Canada license-exempt RSSs. Operation is subject to the following two conditions: (1) this device may not cause interference, and (2) this device must accept any interference, including interference that may cause undesired operation of the device. Any changes or modifications not expressly approved by Philips could void the user's authority to operate this equipment. This equipment is intended for commercial use only.

FCC Radiation Exposure Statement

This equipment complies with FCC radiation exposure limits set forth for an uncontrolled environment. This equipment should be installed and operated with minimum distance 20 cm between the radiator & your body.

IC Radiation Exposure Statement

This equipment complies with IC RSS-102 radiation exposure limits set forth for an uncontrolled environment. This equipment should be installed and operated with minimum distance 20 cm between the radiator & your body.

Open source statement

This product contains open source software. The acknowledgements, license texts and the written offer can be retrieved from the product after installation using a web browser by opening the following web page <https://interact.lighting.com/lightopensource/>. This link allows you to enter the mac address that can be found on the label at the back of the product. This web service will subsequently retrieve the acknowledgments, license texts and written offer from the device with that particular mac address, providing you with the information corresponding to the then current open source software in the device.

