

PHILIPS

CoreLine Widebody Waterproof Batten



Innovative



Easy to install



High quality

**REAL
PROs**
**REAL
QUALITY**

Soggy mess or waterproof success?

Real professionals count on the new **Philips CoreLine Widebody Waterproof Batten**.

It's the suitable retrofit solution for conventional waterproof fittings. With a wider base, sturdy and robust finish, multiple knock-outs and the ability for through wiring, installation is hassle-free and simple.

Key Features and Benefits

- ✓ Wide base for direct replacement of T8 luminaires.
- ✓ Emergency options available (AS2293 compliant).



Applications

- ✓ Warehouses
- ✓ Wet areas
- ✓ Carparks
- ✓ Factories

50,000
hours
@L70

IP65

IK08

5
year
warranty

www.clubblue.co.nz

Simple installation

Speed and ease of install is key with features such as large terminal block, central feed as well as multiple knock-outs for through wiring.

Dimensions

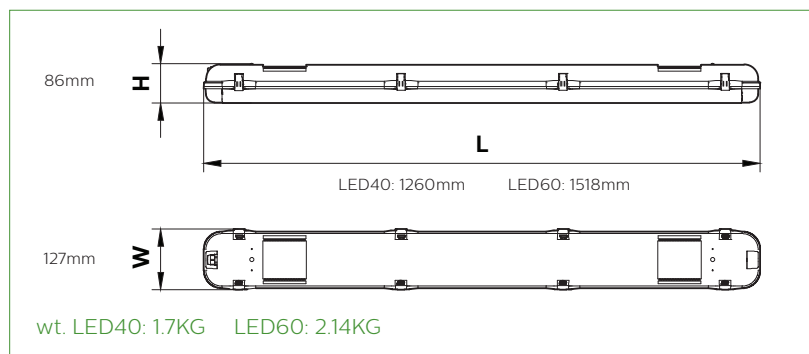

Dimensions shown above are nominal measurement. Slight variation in dimension may occur in producton.

Polar intensity

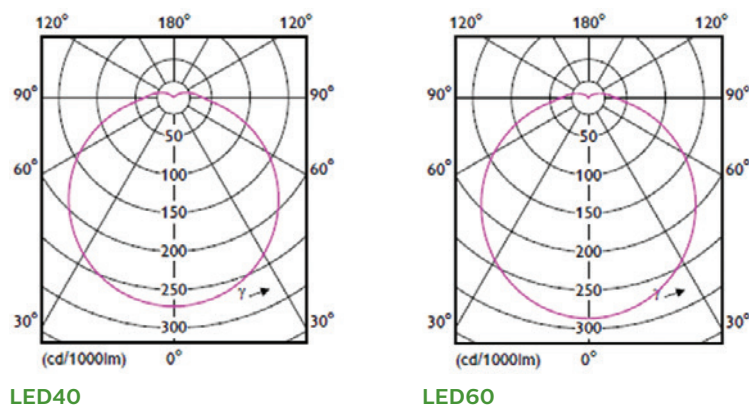

Order codes for the CoreLine Widebody Waterproof Batten

Specification	Part Number	Shortcode
40W, 4000lm, 4000K, 4ft, IP65	911401761162	WT008C L1200 NW 4000lm NZ CL
40W, 4000lm, 6500K, 4ft, IP65	911401761172	WT008C L1200 CW 4000lm NZ CL
60W, 6000lm, 4000K, 5ft, IP65	911401761202	WT008C L1500 NW 6000lm NZ CL
60W, 6000lm, 6500K, 5ft, IP65	911401761212	WT008C L1500 CW 6000lm NZ CL

*Note: Emergency options available on request.

