

PHILIPS

dynalite

PDRAS

Room Automation System



Installation Instructions

Installationsanweisungen

安装说明书

Instructions d'installation

Istruzioni per l'installazione

Instrucciones de instalación

Instrukcje Instalacji

Installatie-instructies

安装指示

 **Devices must be installed by a qualified electrician in accordance with all national and local electrical and construction codes and regulations.**

Die Geräte sind von einem qualifizierten Elektriker in Übereinstimmung mit allen geltenden Vorschriften zu installieren.

按照所有国家和地方电气和施工规范和法规, 设备必须由有资质的电工安装

I dispositivi devono essere installati da un elettricista qualificato in conformità con le norme locali e nazionali vigenti in materia di costruzioni edilizie e installazione di impianti elettrici.

Les appareils doivent être installés par un électricien diplômé conformément à tous les codes et réglementations électriques et de construction nationaux et locaux.

Los dispositivos deben ser instalados por un electricista calificado y cumpliendo todas las normas y regulaciones, tanto nacionales como locales, sobre instalaciones eléctricas y obras.

Urządzenia muszą być zainstalowane przez wykwalifikowanego elektryka, zgodnie ze wszystkimi krajowymi i lokalnymi przepisami, a także regulacjami elektrycznymi i budowlanymi.

De apparaten moeten worden aangebracht door een gekwalificeerde elektricien en in overeenstemming met alle nationale en plaatselijke elektriciteits- en bouwvoorschriften

デバイスは、国および地域の電気および建設に関するすべての法規と規制に従って、資格のある電気技師が設置する必要があります。

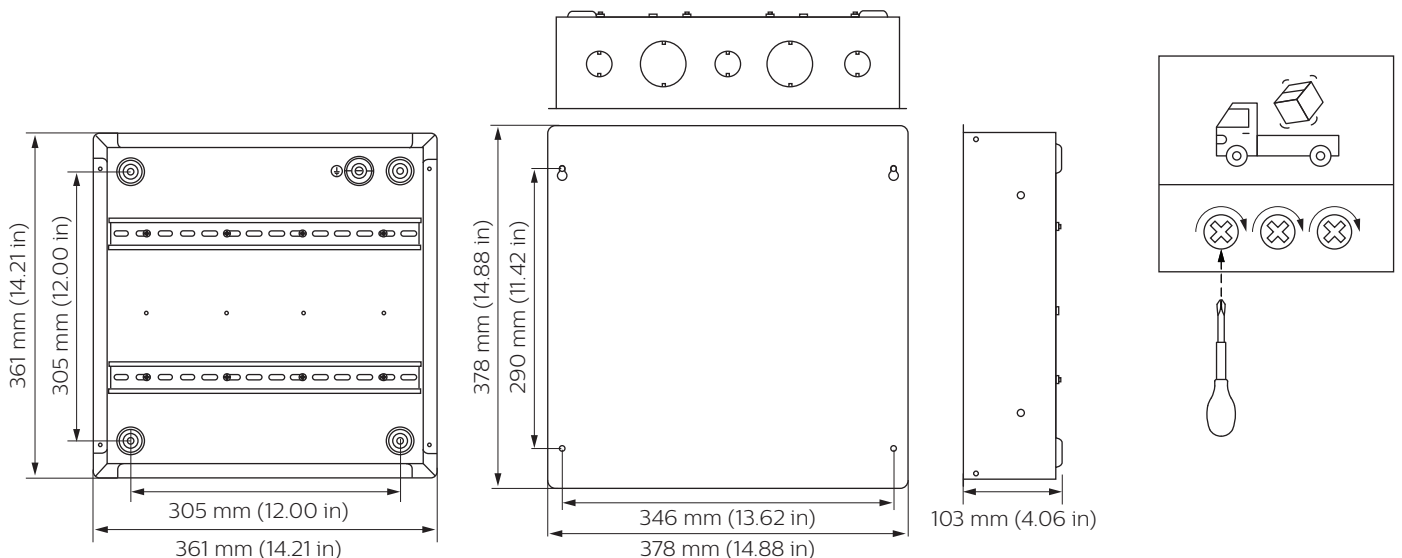
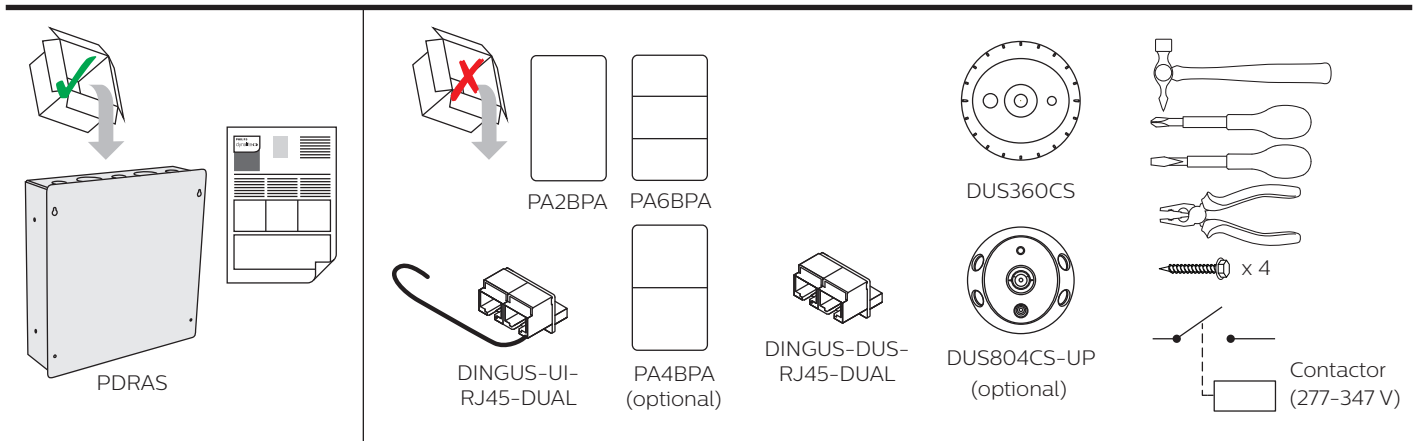

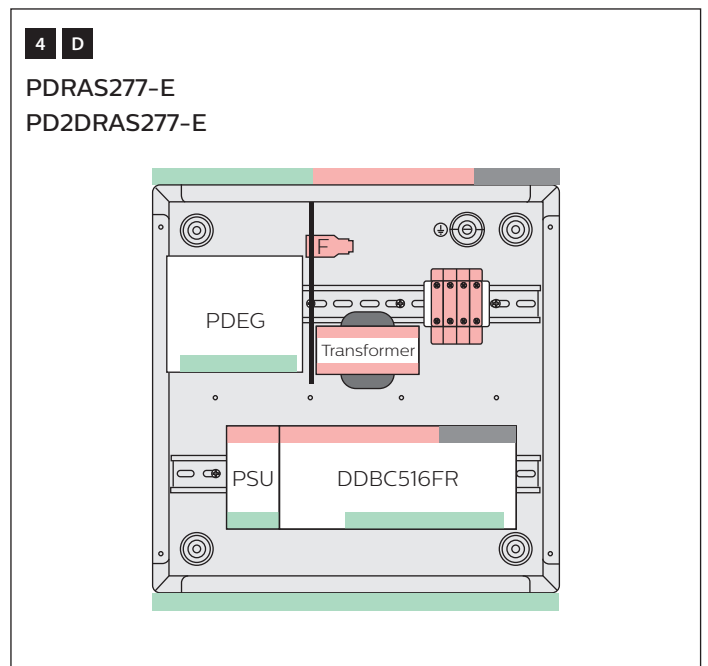
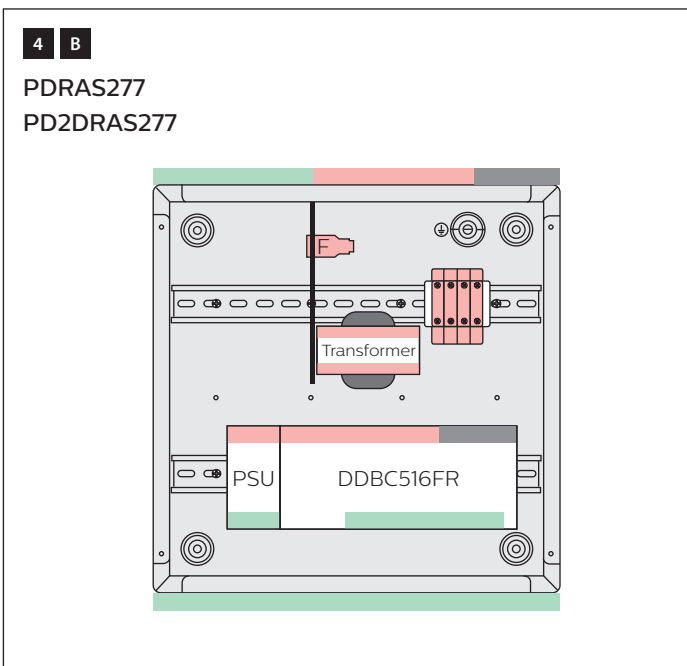
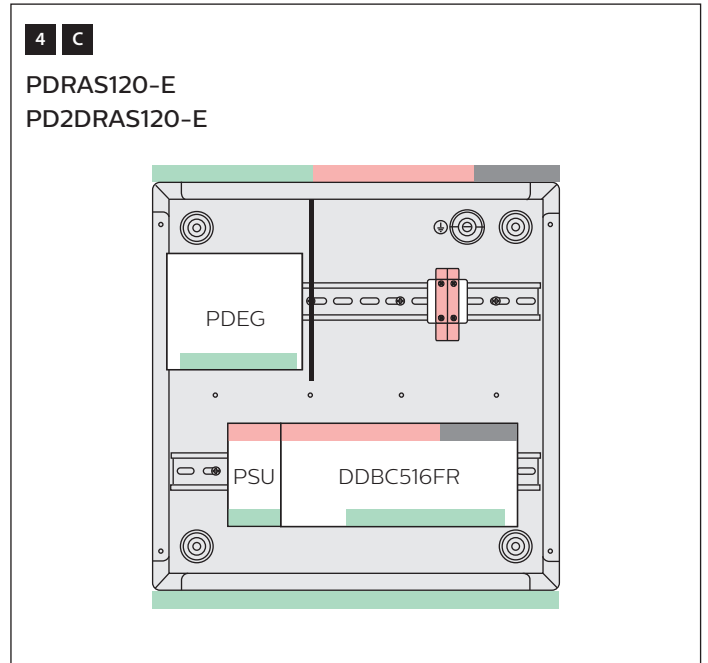
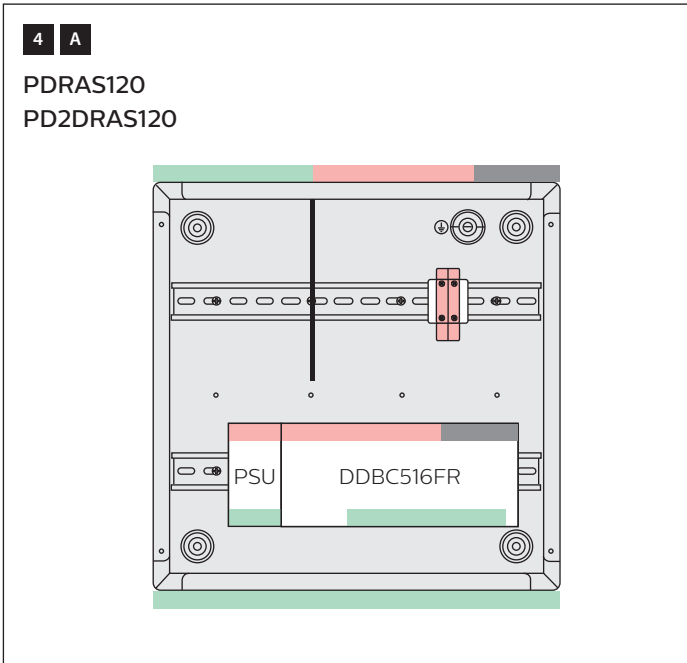
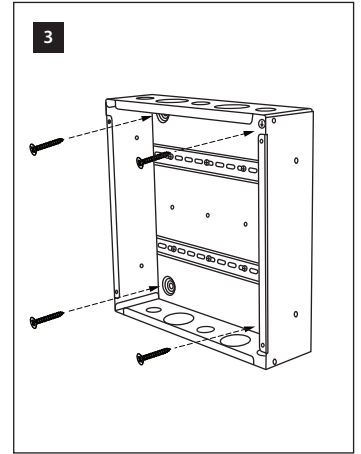
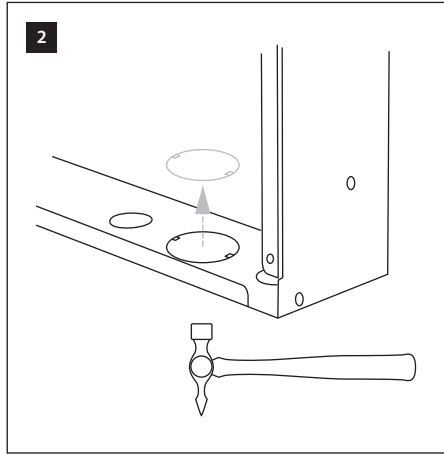
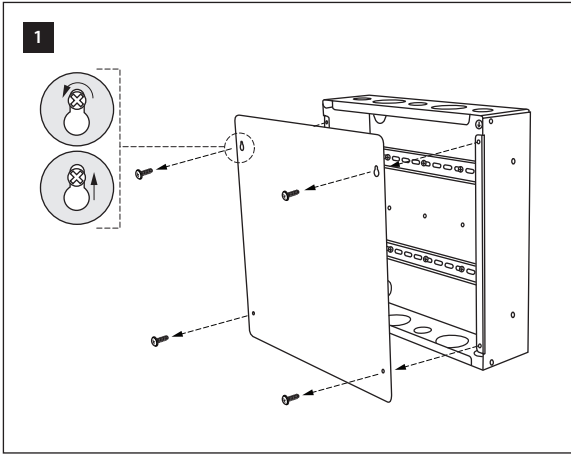

Mains
 SELV/Class 2
 FELV/Class 2, suitable for Class 1 wiring

5



Output Ratings/Channel (CH)

Load Type	CH1-CH5
General Use	16 A, 277 V ~
Incandescent	
Standard Ballast	
Electronic Ballast	
Motor	16 FLA (1 HP), 120 V ~ 14.5 FLA (2 1/2 HP), 240 V ~ 14.1 FLA (3 HP), 277 V ~
Pilot Duty	6 A, 120 V ~ 3 A, 240 V ~ 2.6 A, 277 V ~

Output Ratings/Group

CH-CH ≤ 300 V (UL)/400 V (CE)
DDBC516FR ≤ 80 A

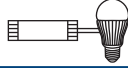
Control Channel Ratings

		
DALI Addressable and Broadcast	≤ 10/CH Guaranteed 20 mA Maximum 250 mA Insulation: basic	≤ 50
DSI	≤ 10/CH	≤ 50
1-10 V	Sink 10 mA Source 10 mA	Driver dependent

6 A

Single-room System

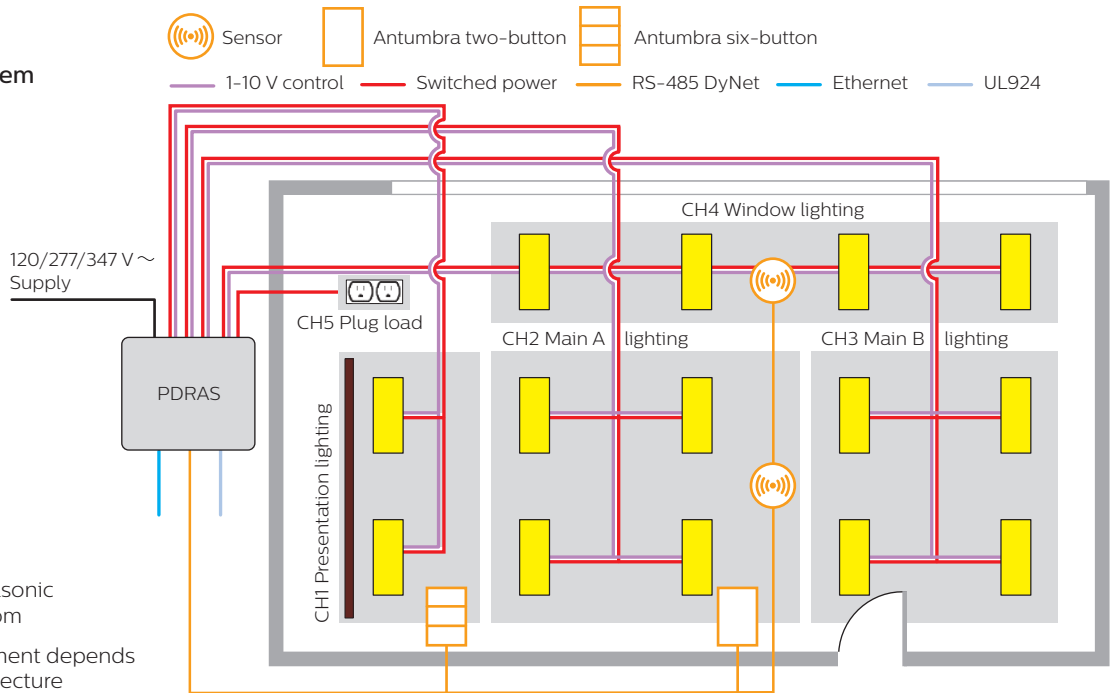

- ! Only one ultrasonic sensor per room
- ! Sensor placement depends on local architecture

6 B

Single-room System

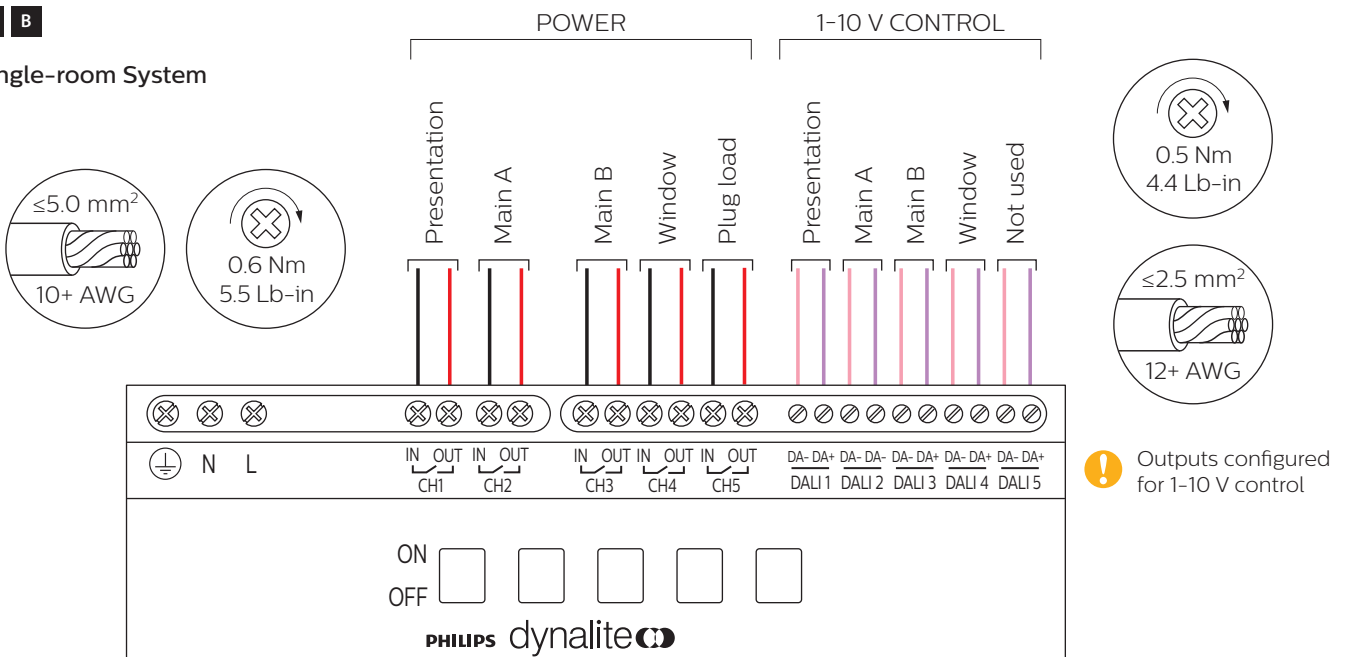

7 A

Dual-room System

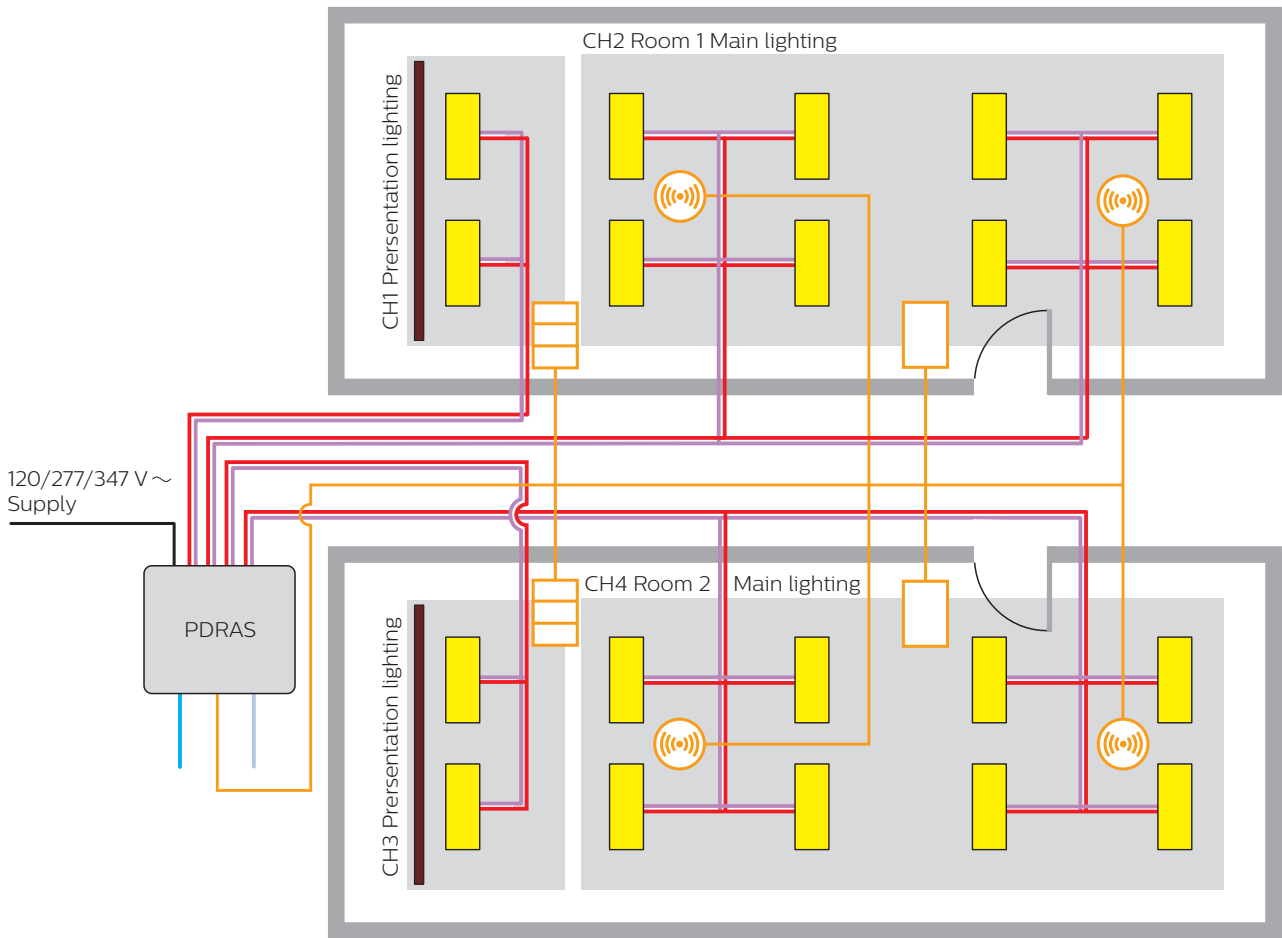

- ! Only one ultrasonic sensor per room
- ! Sensor placement depends on local architecture

7 B

Dual-room System

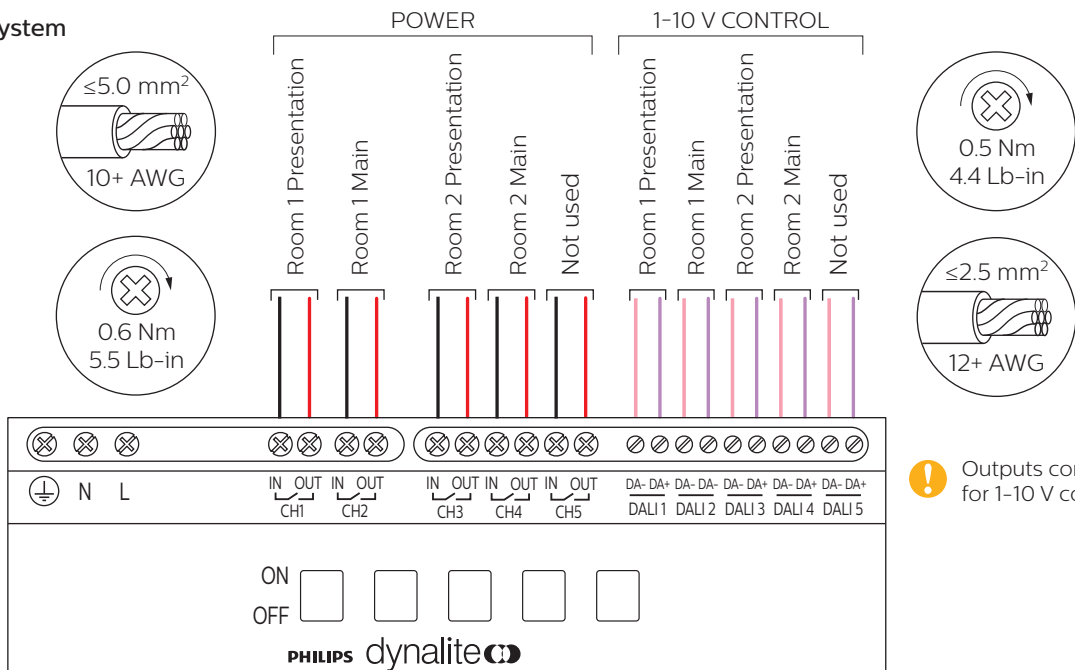

! Outputs configured for 1-10 V control

8

277 - 347 V only

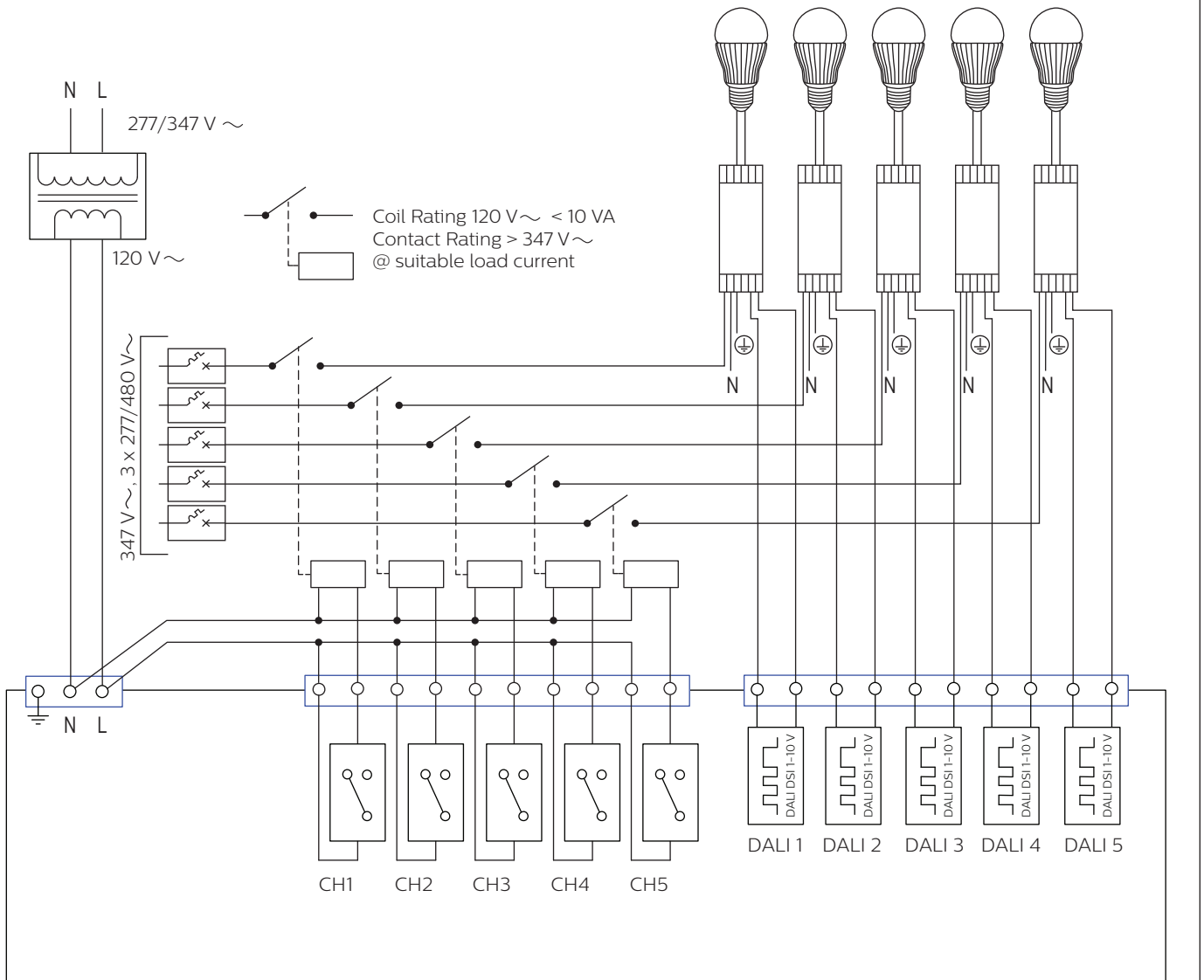

9

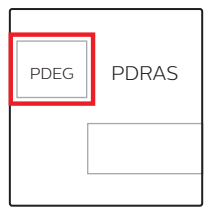

- PDRAS120-E
- PDRAS277-E
- PD2DRAS120-E
- PD2DRAS277-E

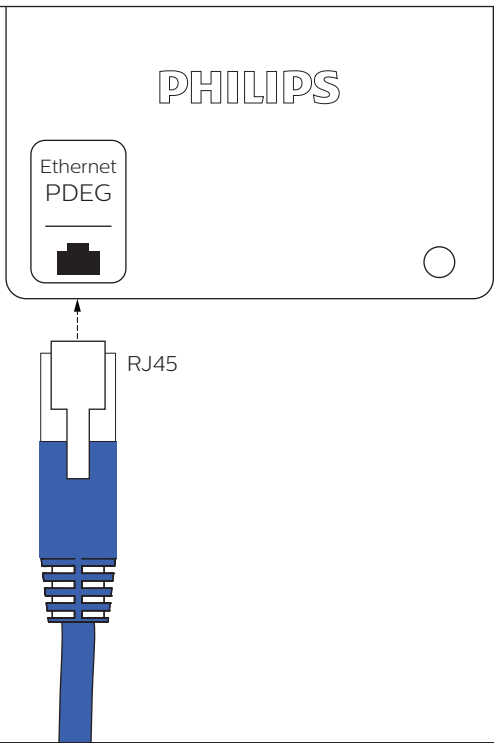

10

Antumbra

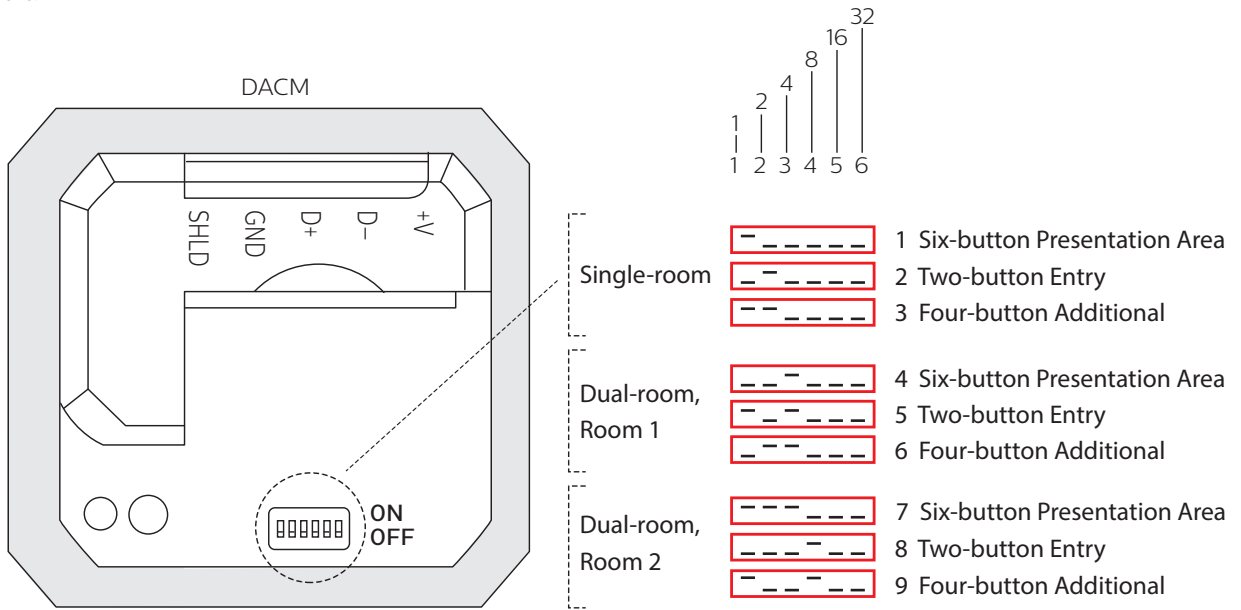

11

Antumbra

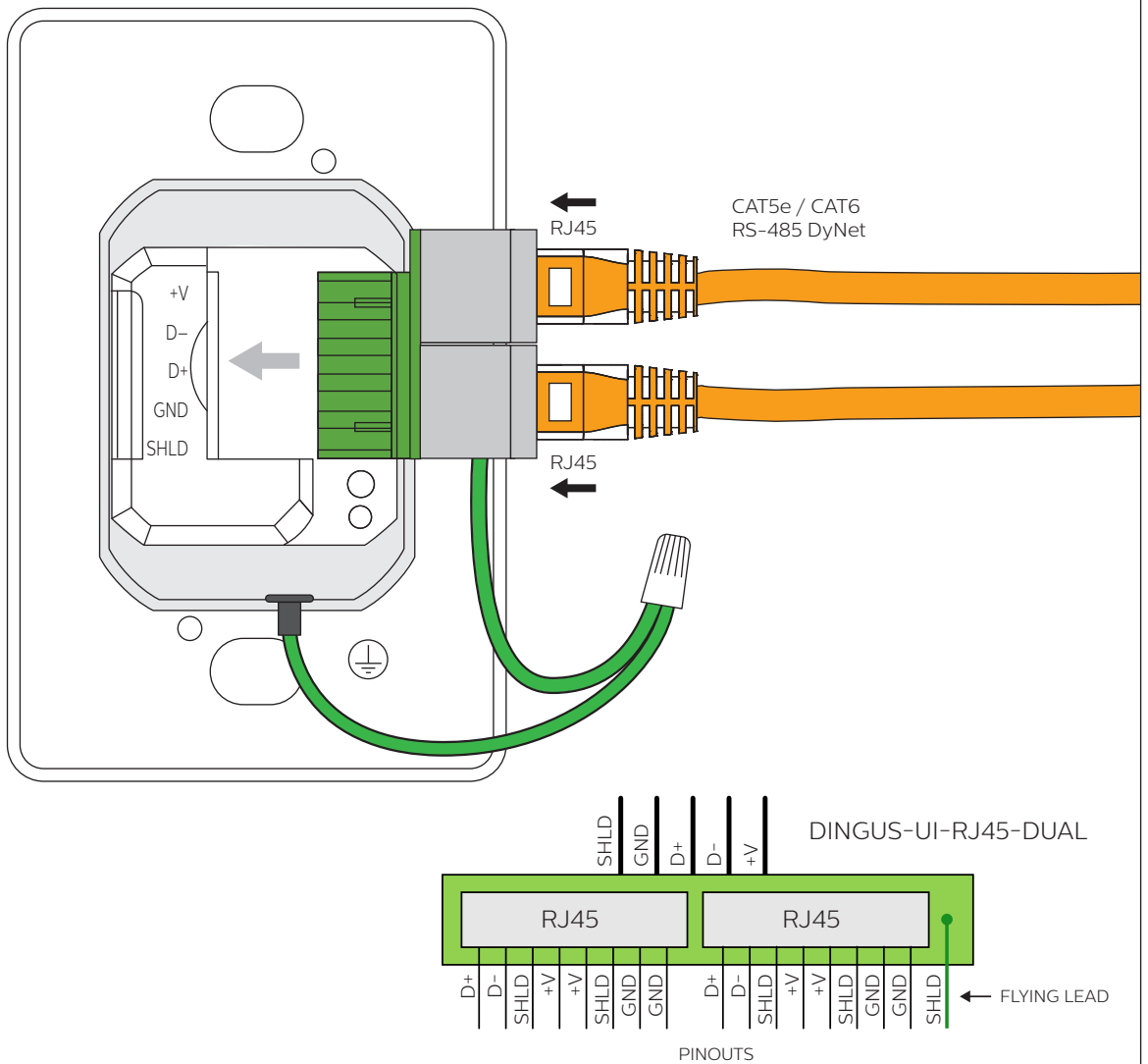

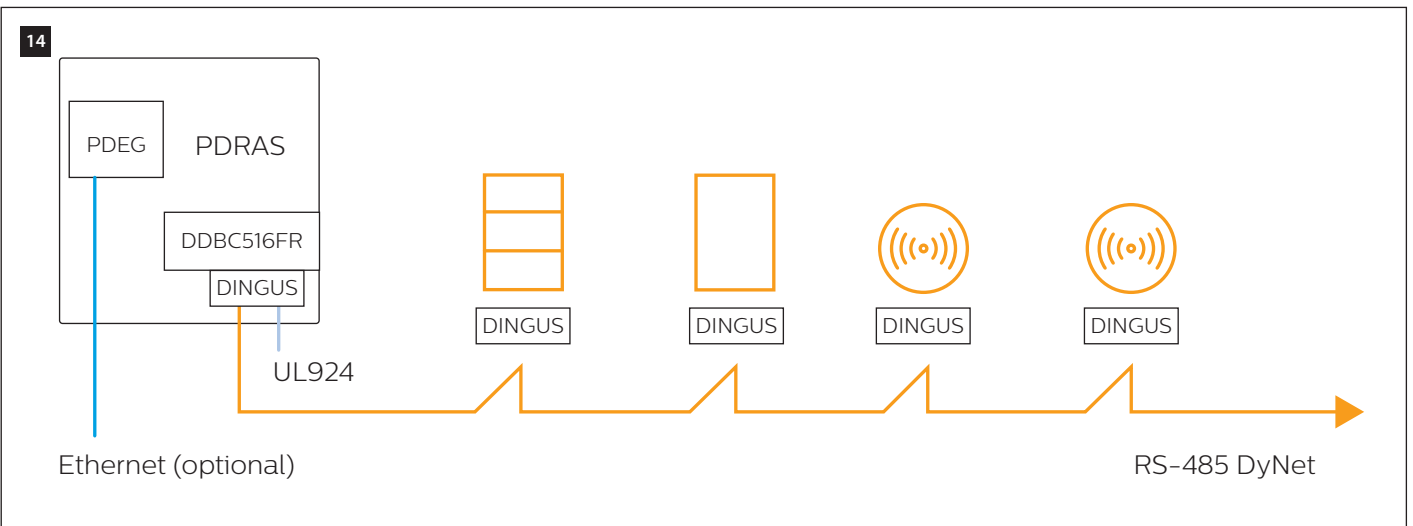
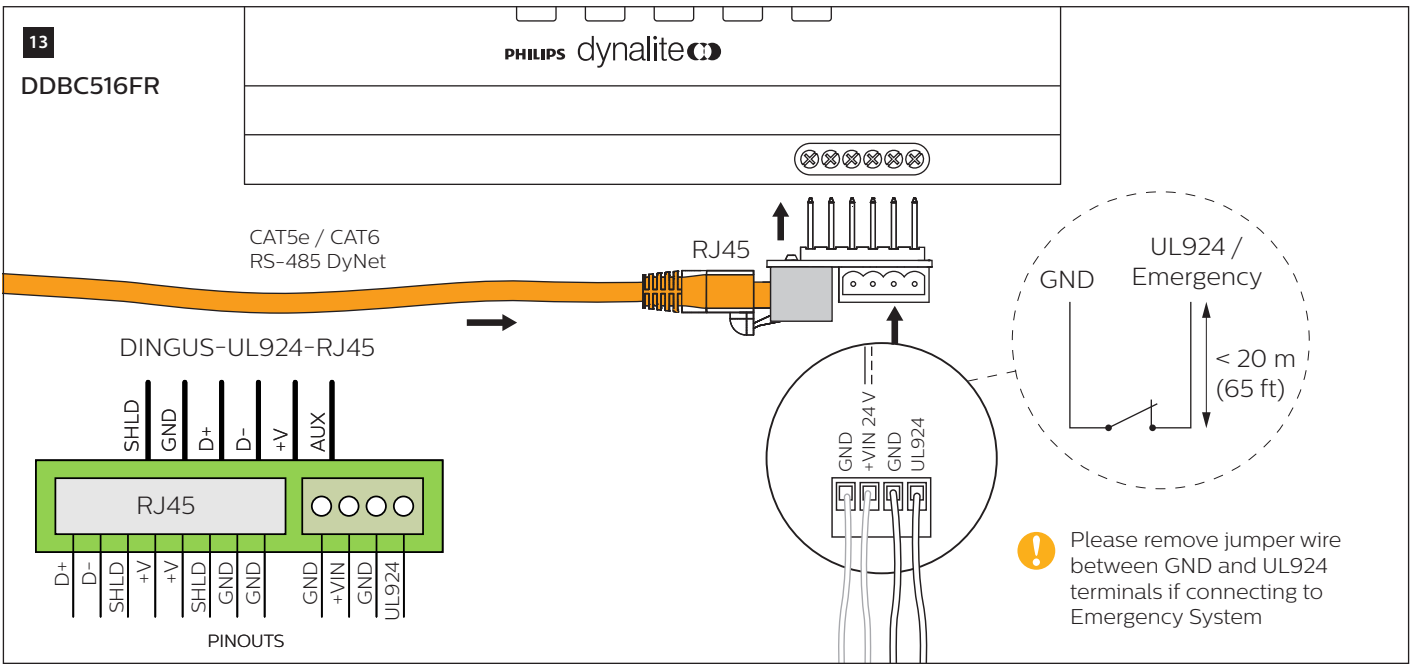
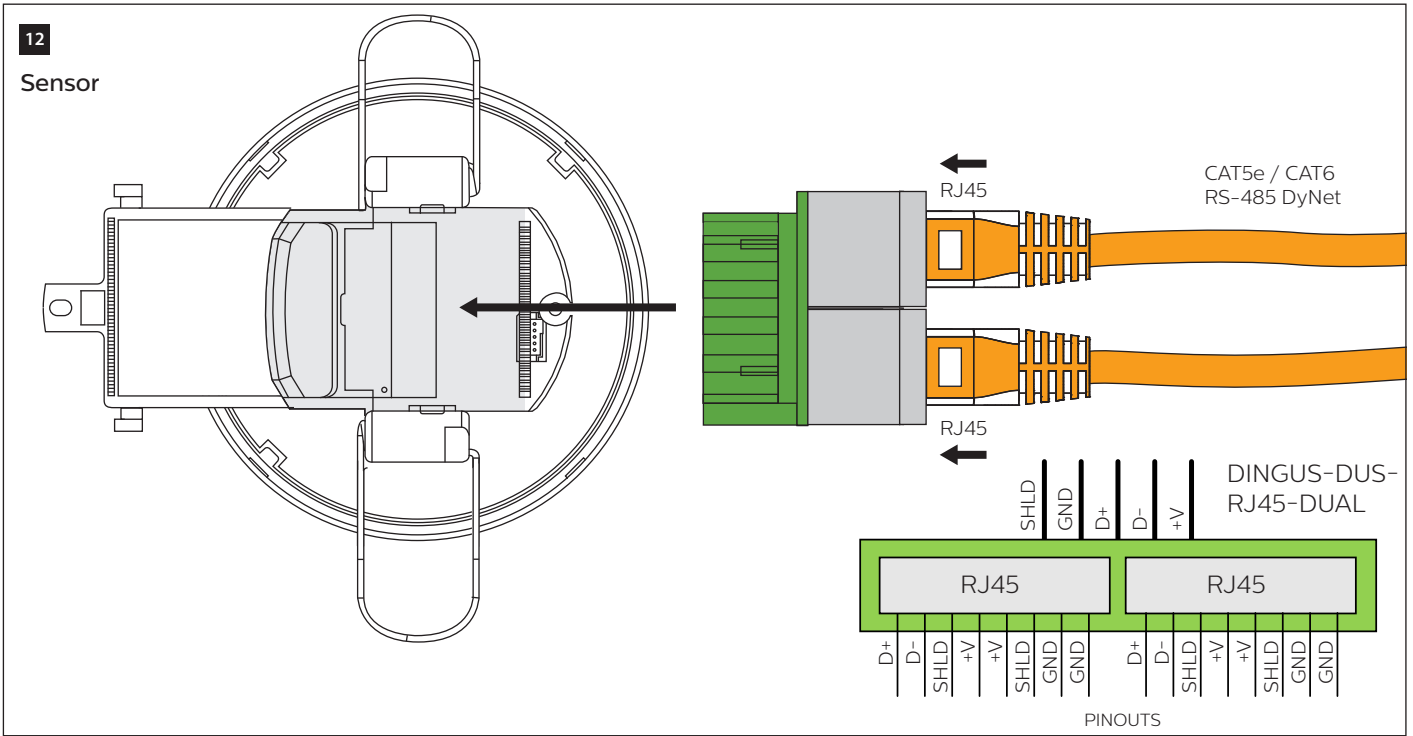

15

347 V only

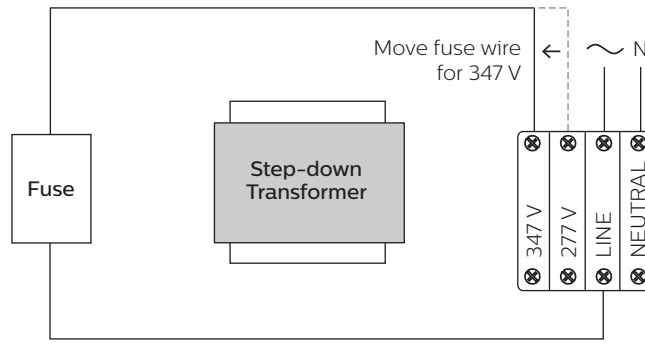

16

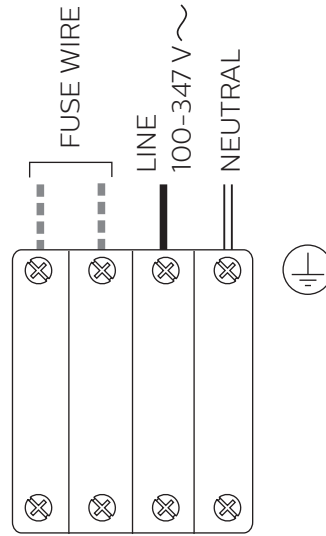
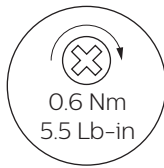
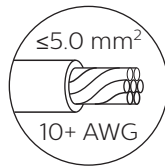

Federal Communications Commission (FCC) Compliance Notice: Radio Frequency Notice – This equipment has been tested and found to comply with the limits for a Class B digital device, pursuant to part 15 of the FCC Rules. These limits are designed to provide reasonable protection against harmful interference in a residential installation. This equipment generates, uses, and can radiate radio frequency energy and, if not installed and used in accordance with the instructions, may cause harmful interference to radio communications. However, there is no guarantee that interference will not occur in a particular installation. If this equipment does cause harmful interference to radio or television reception, which can be determined by turning the equipment off and on, the user is encouraged to try to correct the interference by one or more of the following measures: Reorient or relocate the receiving antenna. Increase the separation between the equipment and receiver. Connect the equipment into an outlet on a circuit different from that to which the receiver is connected. Consult the dealer or an experienced radio/TV technician for help. Any modifications not approved by the manufacturer of this device could void the user's authority to operate this device.

This Class B digital apparatus complies with Canadian ICES-003: CAN ICES-3(B)/NMB-3(B). Cet appareil numérique de la classe B est conforme à la norme NMB-003 du Canada: CAN ICES-3(B)/NMB-3(B).

Suitable for plenum install per NEC 300.22(C)(3).

© 2021 Signify Holding. All rights reserved. Specifications are subject to change without notice. No representation or warranty as to the accuracy or completeness of the information included herein is given and any liability for any action in reliance thereon is disclaimed. Philips and the Philips Shield Emblem are registered trademarks of Koninklijke Philips N.V. All other trademarks are owned by Signify Holding or their respective owners.

