



Dynalite Relay Controllers

DMRC210DA-RJ12

2 channel compact Relay Controller for use with the DUS804C-RJDA occupancy sensor.

2 channel compact Relay Controller for use with the DUS804C-RJDA occupancy sensor.

Product data

| General Information | |
|---------------------------|---|
| CE mark | CE mark |
| Remarks | Please download the Lighting - Product Data Sheet for more information and ordering options |
| RoHS mark | RoHS mark |
| Application Conditions | |
| Ambient temperature range | 0 to +50 °C |
| Product Data | |
| Full product code | 871016352252400 |

| | |
|---------------------------------|----------------|
| Order product name | DMRC210DA-RJ12 |
| EAN/UPC - Product | 8710163522524 |
| Order code | 913703050109 |
| Numerator - Quantity Per Pack | 1 |
| Numerator - Packs per outer box | 1 |
| Material Nr. (12NC) | 913703050109 |
| Net Weight (Piece) | 188.000 g |

Dynalite Relay Controllers

Dimensional drawing

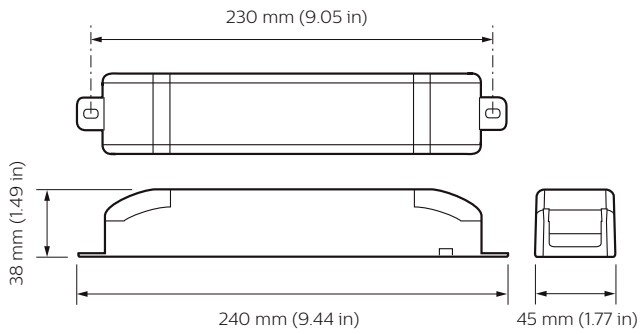

Dynalite Relay Controllers

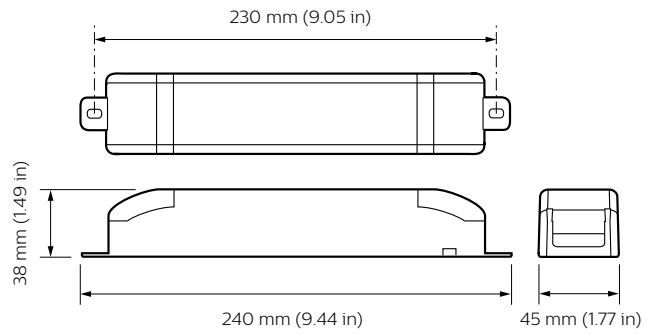

Dynalite Relay Controllers

