



# Dynalite Sensors

## DUS30CS

Wall/ceiling mount 30° multifunction sensor

Wall/ceiling mount 30° multifunction sensor

### Product data

General Information	
CE mark	CE mark
Remarks	Please download the Lighting - Product Data Sheet for more information and ordering options
EU RoHS compliant	Yes

Approval and Application	
Ingress protection code	IP54/20 [ Dust accumulation protected, splash-proof/finger protected]
IP Classification	IP 54 [ Ingress Protection 54]
UL Recognized	Yes

  

Application Conditions	
Ambient temperature range	-20 to +45 °C

Product Data	
Full product code	871869688808700
Order product name	DUS30CS
EAN/UPC - Product	8718696888087
Order code	913703244309
Numerator - Quantity Per Pack	1
Numerator - Packs per outer box	1
Material Nr. (12NC)	913703244309
Net Weight (Piece)	214.000 g

## Dynalite Sensors

### Dimensional drawing

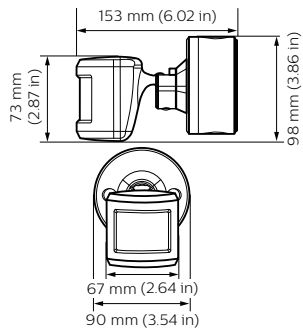

Dynalite Sensors

