



MASTER LEDspot LV

MASTER LED 8-50W+ 830 MR16 36D Dim

Delivering an intense accent beam, the MASTER LEDspot LV is an ideal retrofit solution for spot-lighting. The MASTER LEDspot LV is designed to replace halogen or incandescent spots. It achieves natural colours, enables cosy and comfortable ambience for residential and hospitality usage, and emphasises the beauty of merchandise in retail. A new smaller housing provides perfect fitting with the majority of luminaires on the market with a MR16 GU 5.3 holder. It not only employs Philips's patented solution to guarantee the broadest possible compatibility with standard 12 V halogen electronic transformers, it also delivers high beam intensity which is equivalent to halogen MR16 spots. The dimming function enables users to create the desired atmosphere and it works with broad selection of dimmers. Its high SDCM ensures stricter colour consistency, that is maintained over product life. The MASTER LEDspot LV delivers huge energy savings and minimises maintenance costs without any compromise on light quality and lifetime, enabling residential and business owners to achieve a return on their investment within a short time period.

Product data

General Information		Colour Designation	
Cap base	GU5.3 [GU5.3]	Colour Designation	White (WH)
RoHS mark	RoHS mark	Rated beam angle	36 °
Nominal lifetime (nom.)	40000 h	Colour Temperature, horizontal (Nom)	3000 K
Switching cycle	50000X	Lamp Luminous Efficacy EM (Nom)	82.00 lm/W
Technical type	8-50W	Colour consistency	<4
		Colour Rendering Index,horiz (Nom)	80
		LLMF at end of nominal lifetime (nom.)	70 %
Light Technical		Operating and Electrical	
Colour Code	830 [CCT of 3,000 K]	Power (Rated) (Nom)	8 W
Technical Beam Angle (Nom)	36 °	Lamp current (nom.)	960 mA
Lamp Luminous Flux 25°C EL (Nom)	660 lm	Wattage equivalent	50 W
Lamp Luminous Flux (Nom)	660 lm	Starting time (nom.)	0.5 s
Luminous intensity (nom.)	1700 cd		

MASTER LEDspot LV

Warm-up time to 60% light (nom.)	0.5 s
Power factor (nom.)	0.7
Voltage (Nom)	12 V
Temperature	
T-Case maximum (nom.)	100 °C
Controls and Dimming	
Dimmable	Yes
Approval and Application	
Energy efficiency label (EEL)	A+
Suitable for accent lighting	Yes

Energy Consumption kWh/1000 h	9 kWh
Product Data	
Full product code	871869681301000
Order product name	MASTER LED 8-50W+ 830 MR16 36D Dim
EAN/UPC – product	8718696813010
Order code	929001881708
Numerator – quantity per pack	1
Numerator – packs per outer box	10
Material no. (12NC)	929001881708
Net weight (piece)	0.052 kg

Dimensional drawing

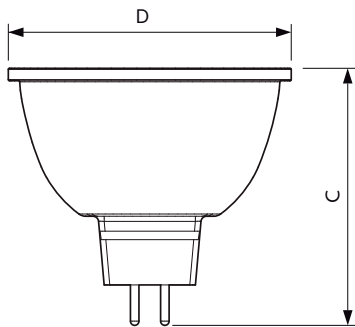

MR16 12V 8-50W 621lm 36D 3000K GU5.3 D

Product	D	C
MASTER LED 8-50W+ 830 MR16 36D Dim	50.5 mm	46.5 mm

Photometric data

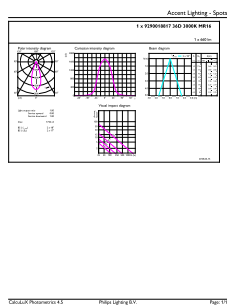

8-50W GU5-3 MR16 36D 830 3000K

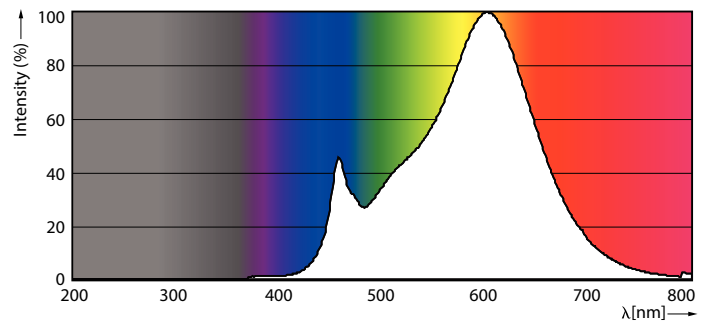

8-50W GU5-3 MR16

MASTER LEDspot LV

Photometric data

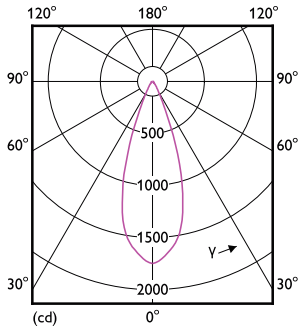

8-50W GU5-3 MR16 36D 827 2700K

Lifetime

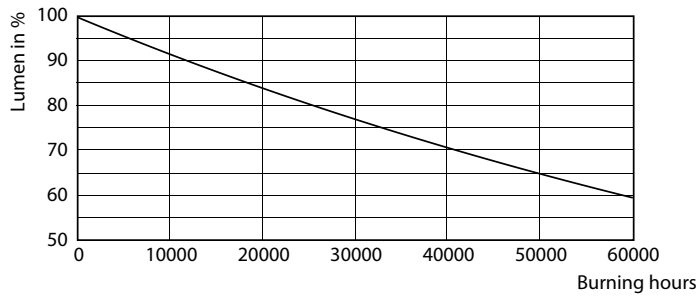

7-50W GU5-3 MR16

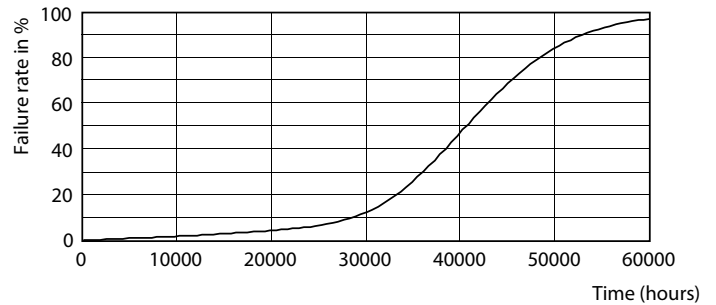

7-50W GU5-3 MR16

