

PHILIPS
hue

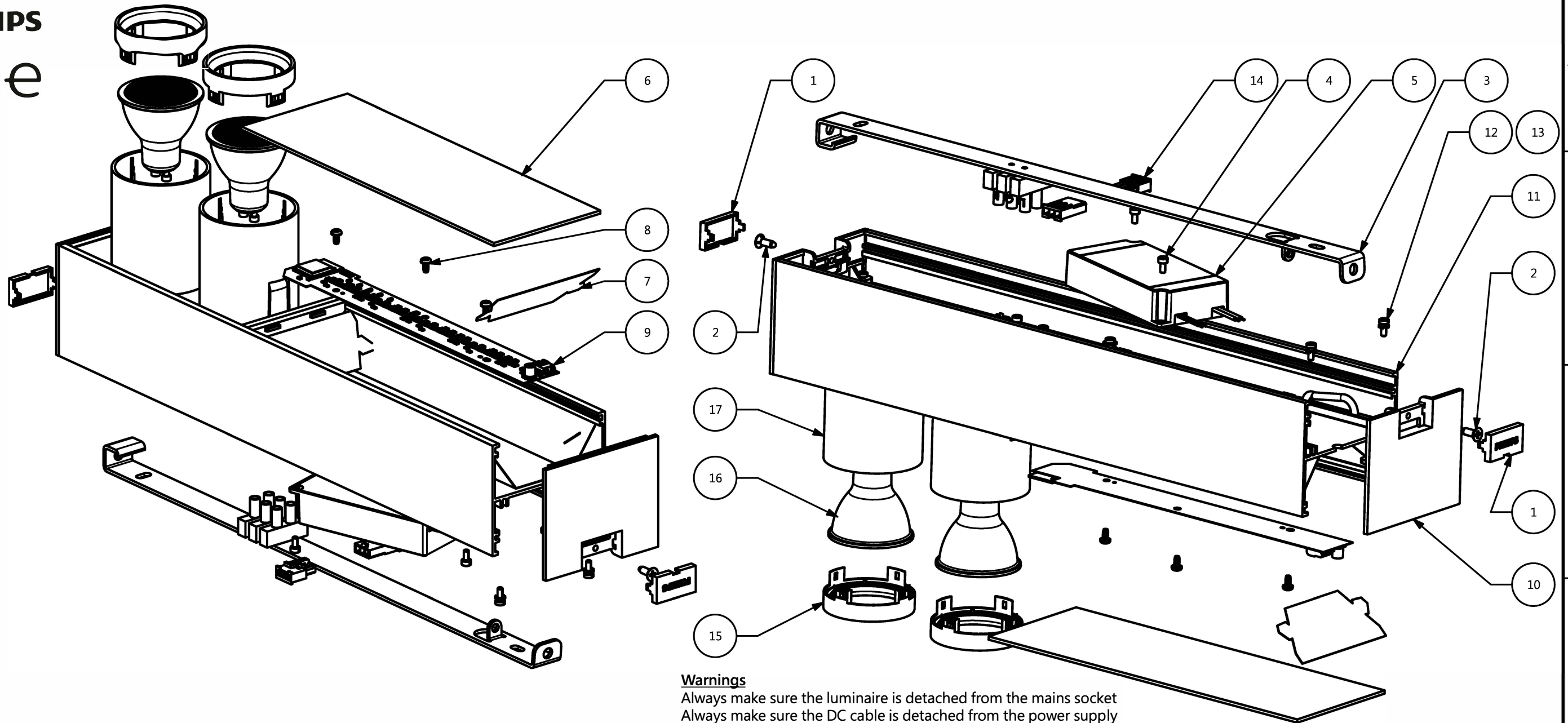

Warnings

Always make sure the luminaire is detached from the mains socket
Always make sure the DC cable is detached from the power supply
Staring at the operating light source may cause eye injury

#	COMPONENT	QTY
1	COVER	2
2	SCREW	2
3	BRACKET	1
4	SCREW	2
5	CONTROL GEAR - PSU	1
6	DIFFUSER	1
7	REFLECTOR	1
8	SCREW	3
9	LIGHT SOURCE - LED MODULE	1
10	END CAP	1
11	PROFILE	1
12	SCREW	2
13	WASHER	2
14	TERMINAL BLOCK	1
15	COVER	2
16	GU 10 BULB	2
17	TUBE	2

SKU	Color	Country
915005928301	WHITE	EU/UK
915005928101	BLACK	EU/UK

#	Disassembly Instructions	Tools needed
a	REMOVE BOTH COVERS (1) GENTLY LIFTING THEM OUT	FLATHEAD SCREWDRIVER
b	UNSCREW BOTH SCREWS (2)	CROSSHEAD SCREWDRIVER PZ
c	DISCONNECT TERMINAL BLOCK (14) SLIDING IT OUT AT THE SAME TIME PUSHING SAFETY LEVER ON IT	-
d	TAKE A SIDE BRACKET (3) UNHOOKING IT FROM END CAPS	-
e	REMOVE MARKED END CAP (10) BY UNSCREWING BOTH SCREWS (12)	TORXHEAD SCREW DRIVER T10
f	SLIDE OUT DIFFUSER (6)	
g	PULL OUT REFLECTOR (7)	
h	UNPLUG WIRES FROM LIGHT SOURCE-LED MODULE (9)	WAGO TOOL #2060
i	REMOVE LIGHT SOURCE-LED MODULE (9) BY UNSCREWING 3x SCREWS (8)	TORXHEAD SCREW DRIVER T10
j	CUT OUT MAIN WIRES OF CONTROL GEAR PSU (5)	CUTTING PLIERS
k	REMOVE CONTROL GEAR PSU (5) BY UNSCREWING SCREWS (4)	ALLEN KEY
l	REMOVE BOTH COVERS (15) ROTATING THEM AND PULLING OUT FROM TUBES (17)	
m	REMOVE GU 10 BULBS (15) ROTATING THEM OUT	

STATUS	DESCRIPTION	DESIGN ID	03	2021-08-04
Centris Hue special form 2x5.7W white/black - Disassembly instruction		DOC 12NC		
NAME	T.O	LOCAL PART ID 096936	SH. 1	SH. 511
CHECKED	DATE	2021-08-04		A3-L