



MASTER MHN-FC

MASTER MHN-FC 2000W/740 400V XW

Compact quartz metal halide lamps with double pinch

Warnings and Safety

- Use only in totally enclosed luminaire, even during testing (IEC61167, IEC 62035, IEC60598)
- The luminaire must be able to contain hot lamp parts if the lamp ruptures
- A lamp breaking is extremely unlikely to have any impact on your health. If a lamp breaks, ventilate the room for 30 minutes and remove the parts, preferably with gloves. Put them in a sealed plastic bag and take it to your local waste facilities for recycling. Do not use a vacuum cleaner.

Product data

General Information	
Cap base	Double Ended
Operating position	P5 [Parallel +/-5D or Horizontal(HOR)]
Life to 50% failures (nom.)	12,000 h

Light Technical	
Colour Code	740 [CCT of 4000K]
Colour designation	White (WH)
Chromaticity Coordinate X (Nom)	380
Chromaticity Coordinate Y (Nom)	419
Correlated Colour Temperature (Nom)	4200 K
Luminous efficacy (rated) (nom.)	102 lm/W
Colour rendering index (CRI)	60
Arc Length O (Nom)	108 mm

Operating and Electrical	
Power Consumption	2,050 W
Voltage (nom.)	222 V

Controls and Dimming	
Dimmable	No

Mechanical and Housing	
Lamp Finish	Clear
Net Weight (Piece)	0.190 kg

Approval and Application	
Mercury (Hg) content (nom.)	105 mg
Energy consumption kWh/1,000 hours	2,235 kWh

Product Data	
Order product name	MASTER MHN-FC 2000W/740 400V XW
Full product name	MASTER MHN-FC 2000W/740 400V XW
Full EOC	871150021349500
Order code	928070405130
Material no. (12 NC)	928070405130
Local order code	2000MHNFC740
Numerator – quantity per pack	1

MASTER MHN-FC

EAN/UPC – Product/Case	8718291548195
Numerator – packs per outer box	1
EAN/UPC - Case	8711500213495

Dimensional drawing

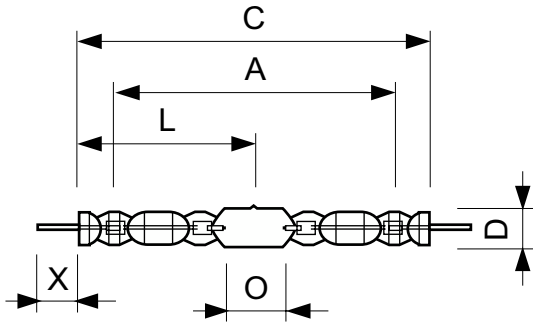

Product	D (max)	D	O	X	L	A	C (max)
MASTER MHN-FC 2000W/740 400V XW	33 mm	25.5 mm	108 mm	58 mm	177 mm	290 mm	357 mm

Photometric data

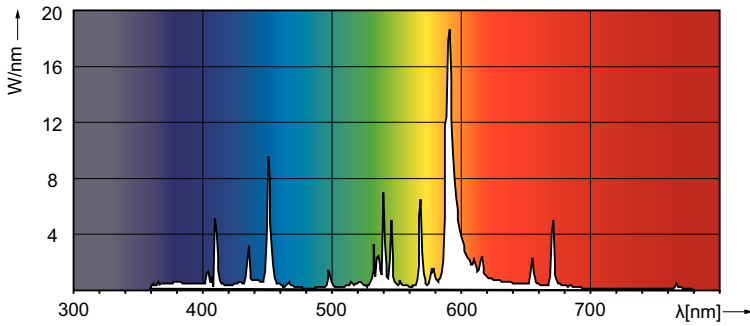

Spectral Power Distribution Colour - MASTER MHN-FC 2000W/740 400V XW

Lifetime

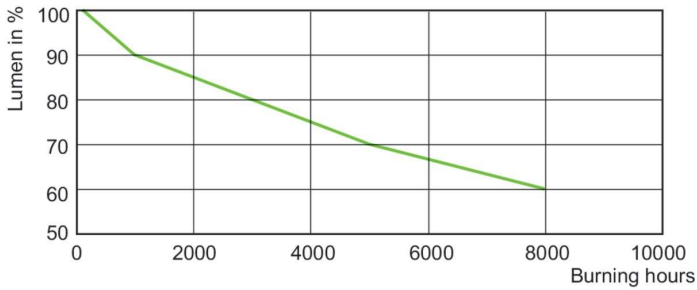

Lumen Maintenance Diagram - MASTER MHN-FC 2000W/740 400V XW

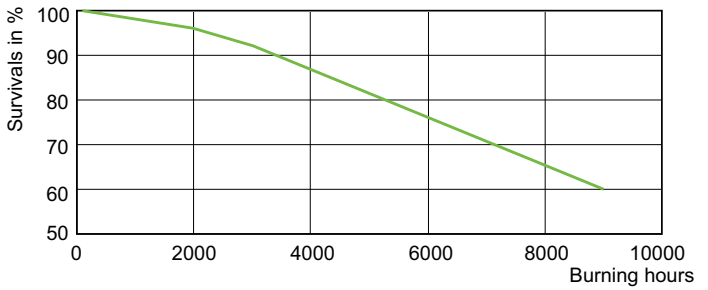

LDLE_MHN-FC_2000W_740-Life expectancy diagram

