



EasyAir SNM212 MC

System Description and Technical Specifications

The EasyAir SNM212 MC mid-bay sensor is the ideal solution for per-fixture control of new light luminaires in applications with mounting heights between 4 m and 12.2 m. The sensor comes in a compact, appealing shape for mounting to the front side of a luminaire. It combines occupancy sensing, daylight harvesting and task tuning in a single package. EasyAir SNM212 MC operates with Xitanium SR or D4i certified drivers via a simple two-wire connection between sensor and driver, thus eliminating the need for multiple components and auxiliary devices. The result is a cost-effective and easy-to-design-in solution ideal for energy-savings. An intuitive app makes configuration and commissioning during and after installation fast and easy using the Philips MasterConnect app.

EasyAir SNM212 MC is commissioned and configured via Bluetooth available on modern smartphones. The sensors do not require gateways, network connections or dashboards. The sensors in the group communicate to each other via Zigbee for simple area-based control. It is an easy way to achieve energy savings in mid-bay applications while maintaining aesthetics in the space.

Product features

- 4 m to 12.2 m mounting height; IP66 rated
- Occupancy sensing, daylight harvesting and task tuning in one device
- Groups/networks up to 120 lights
- Out-of-the-box light regulation with preset sensor parameters
- Zigbee 3.0 and D4i certified
- Operates with Philips Xitanium SR drivers, D4i certified drivers and qualified wireless switches
- 2-wire connection, with Xitanium SR drivers or SR bridge
- Selection of luminaires using a list based on BLE or pointing with a flashlight
- Energy reporting capability using actual driver energy consumption
- Configuration of sensor parameters- if desired - using Philips MasterConnect app, available on Google PlayStore and in Apple App Store for free.

Benefits

- Combines functionality to reduce need for multiple components
- Quick task tuning in the field to optimize light and power levels
- Cost-effective solution for energy-savings
- 5-year limited system warranty with Philips Xitanium LED drivers
- Configuration and commissioning from the floor via Bluetooth
- Compatibility with qualified gateways

Applications

- Warehouses
- Assembly areas
- Cold storage

MasterConnect System

https://www.signify.com/global/prof/led-electronics/masterconnect-system/SMC_LEDELECTRCONN_CA/category



EasyAir SNM212 MC

Product data

Physical Information

Overall Dimensions	Refer to drawing
Net Weight per Piece	44g (without shield)
Housing (Luminaire Hole)	Diameter 22 mm
Color	White or grey
Wiring	(2) 18AWG wires, unpolarized; 8mm strip length

Electrical Information

Input Voltage	Powered by SR driver low voltage interface
Current Consumption	9.5mA at 15V (average)
Nominal Power Consumption	140mW (average)
Standby Power	<0.6W at fixture level including driver standby power
Activation	Sensors regulate light output out of the box with default settings

Occupancy Sensing

Type	Passive infrared (PIR)
Occupancy Based Control	Default enabled
Occupancy Mode	Auto-on/auto-off; Manual-on/auto-off ; Manual-on / manual-off
Group/Zone Occupancy Sharing	Enabled/disabled
Group/Zone Lighting Behavior	Background level/Eco-on level
Eco-On Level	1% - 100%
Hold Time	2 minutes - 100 minutes
Viewing Angle	± 51 °
Background Light Level	1% - 100%
Prolong Time	2 minutes - 100 minutes, or infinite
Grace Fading	1 second - 25 seconds
Response Time/Fading to Switch On/Off	1 second

Daylight Sensing

Daylight based control	Enabled/disabled. Default Enabled with target light level of “~100lux X Eco-ON%”.
Calibration	Selectable. Light Level calibrated to “Max light output from fixture X Eco-ON%”.
Viewing Angle	110° (half value sensitivity)
Light sensing sensitivity	2 - 2000 lux

Task Tuning

Full light setting	0% - 100%
Tunable White	With Philips FlexTune driver, default factory setting: 4000K

EasyAir SNM212 MC

Product data

Environment & Approbation

Operating Ambient Temperature Range	-30°C to +55°C
Operating Humidity Range	20% to 85% relative humidity
Ingress Protection (IP) Rating	Tested for compliance to IP66 (front side) by Dekra
Storage Temperature Range	-30°C to +80°C
Max Case Temperature (Tcase)	+60°C
Agency Approbations	CE, ENEC, CB, UKCA, RED, RCM
Warranty	5 years
Digital Interface	Xitanium SR, D4i

Other

Wireless Protocol	Zigbee, IEEE 802.15.4, Bluetooth Low Energy
Encryption	AES-128
Energy reporting	Group-level using the Philips MasterConnect App or project-, group-, and zone-level using the MasterConnect gateway
No. SR-Drivers per Sensor	4 max
Max Distance Switch-to-First Sensor	15m line-of-sight
Max Distance Sensor-to-Sensor	15m line-of-sight
Max no. Sensors per Group	120
No. of Zones per Group	15 max.
No. Switches per Group	15 max, 5 max per zone
Mounting Height	4 m to 12.2 m
Field Configuration	via Bluetooth with Philips MasterConnect app

Ordering information

Commercial product name	Colour	Description	EOC	12NC	MOQ
EasyAir SNM212/w MC	White	Mid-bay luminaire integrated sensor in white	872110311454900	9290 034 55606	10
EasyAir SNM212/g MC	Grey	Mid-bay luminaire integrated sensor in grey	872110308699000	9290 039 18306	10

EasyAir SNM212 MC

Compatible LED drivers

Easy Air SNM212 MC can be operated with Philips Xitanium SR drivers and with D4i certified drivers. The following Xitanium drivers are compatible:

Logistic code 12NC	Description
9290 034 23706	Xitanium SR Bridge built-in
9290 034 23806	Xitanium SR Bridge independent
9290 016 95806	Xitanium 150W 0.2-0.7A 300V SR 230V iXt
9290 016 95706	Xitanium 100W 0.15-0.5A 300V SR 230V iXt
9290 028 80406	Xitanium 12W 0.08-0.5A 25V SR 230V
9290 028 80506	Xitanium 23W 0.15-0.7A 41V SR 230V
9290 034 10806	Xitanium 90W 0.25-0.7A 220V SR 230V G2
9290 034 10506	Xitanium 35W 0.08-0.35A 220V SR 230V G2
9290 034 10606	Xitanium 60W 0.15-0.5A 220V SR 230V G2
9290 016 93706	Xitanium 36W 0.08-0.4A 220V SR FlexTune 230V
9290 016 93806	Xitanium 75W 0.15-0.7A 220V SR FlexTune 230V
9290 028 61106	Xitanium 20W WH 0.15-0.5A 54V SR Is 230V
9290 028 61206	Xitanium 36W WH 0.3-1.05A 54V SR Is 230V
9290 028 61306	Xitanium 50W WH 0.7-1.5A 54V SR Is 230V
9290 029 33606	Xitanium 36W 0.3-1.0A 54V SR 230V G2
9290 029 33706	Xitanium 75W 0.7-2.0A 54V SR 230V G2
9290 021 78906	Xi SR 22W 0.3-1.0A SNEMP 230V C133 sXt
9290 021 78806	Xi SR 22W 0.2-0.7A SNEMP 230V C133 sXt
9290 021 79006	Xi SR 40W 0.2-0.7A SNEMP 230V C133 sXt
9290 021 79106	Xi SR 40W 0.3-1.0A SNEMP 230V C133 sXt
9290 021 71906	Xi SR 75W 0.2-0.7A SNEMP 230V S240 sXt
9290 021 72006	Xi SR 75W 0.3-1.0A SNEMP 230V S240 sXt
9290 028 27206	Xi SR 75W 0.2-1.0A SNEMP 230V C150 sXt
9290 021 72106	Xi SR 150W 0.2-0.7A SNEMP 230V S240 sXt
9290 021 72206	Xi SR 150W 0.3-1.0A SNEMP 230V S240 sXt

EasyAir SNM212 MC

Sensor dimensions

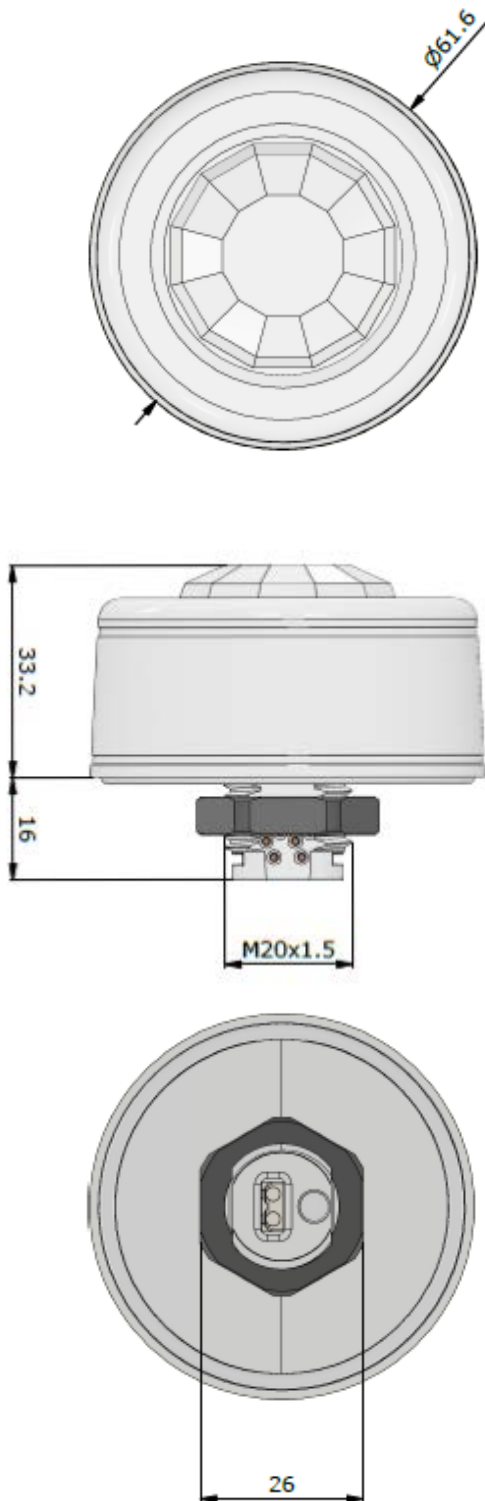

Mounting

SNM212 MC is mounted in the luminaire via a 22mm hole in the housing and fixed with a nut.

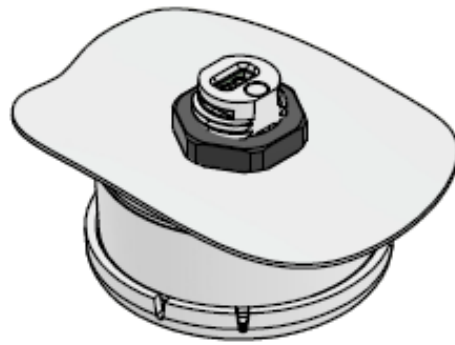

Shield for field of view occupancy detection

Sections can be cut and removed to open the field of view for occupancy detection according to the needs of the application (e.g. aisle, view to one side only).

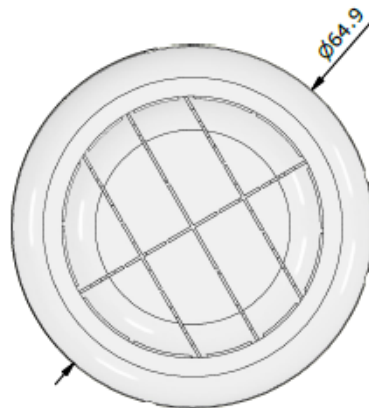

Colours



White



Grey

EasyAir SNM212 MC

Wiring diagram

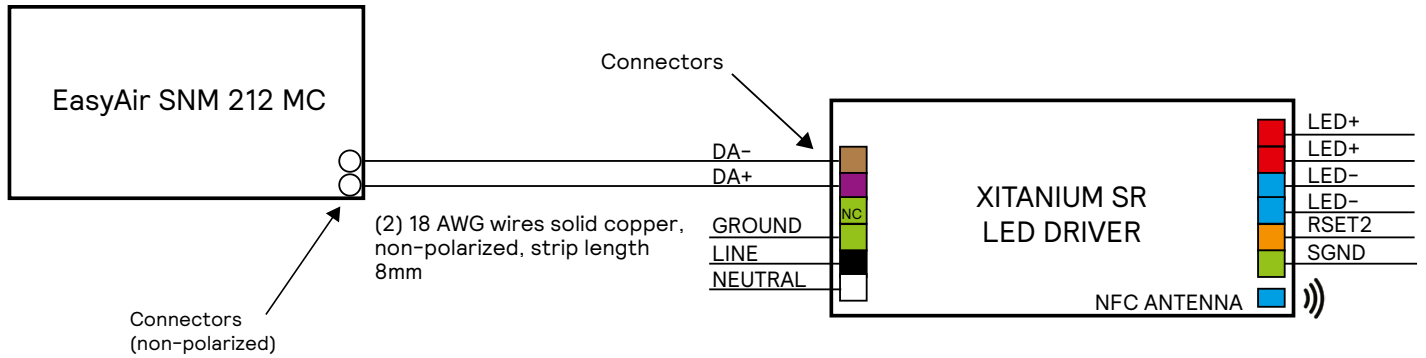

EasyAir SNM212 MC

Occupancy sensing detection patterns

The plots below show the top and side view of the occupancy coverage based on NEMA test, an industry standard.

In the side view, it is visible that coverage ratio of mounting height: diameter at ground level is at maximum 2.5:1. For example if the mounting height is 12m, the maximum diameter coverage is 30m.

Disclaimer:

1. In these plots, the white areas are blind spots and the detection is based on subject's motion. An idle subject may not continue to trigger occupancy detection once the hold time expires.
2. As PIR based sensing works on temperature difference between the subject and the ground level, the occupancy detection could vary due to clothing and size of subject.

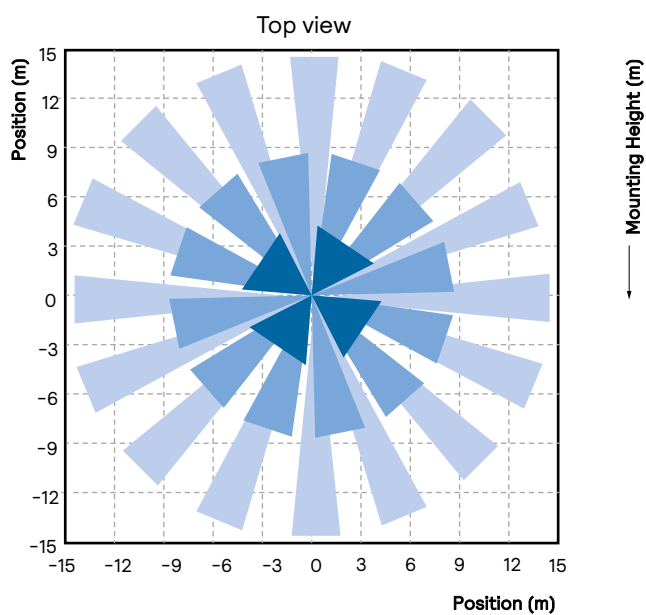
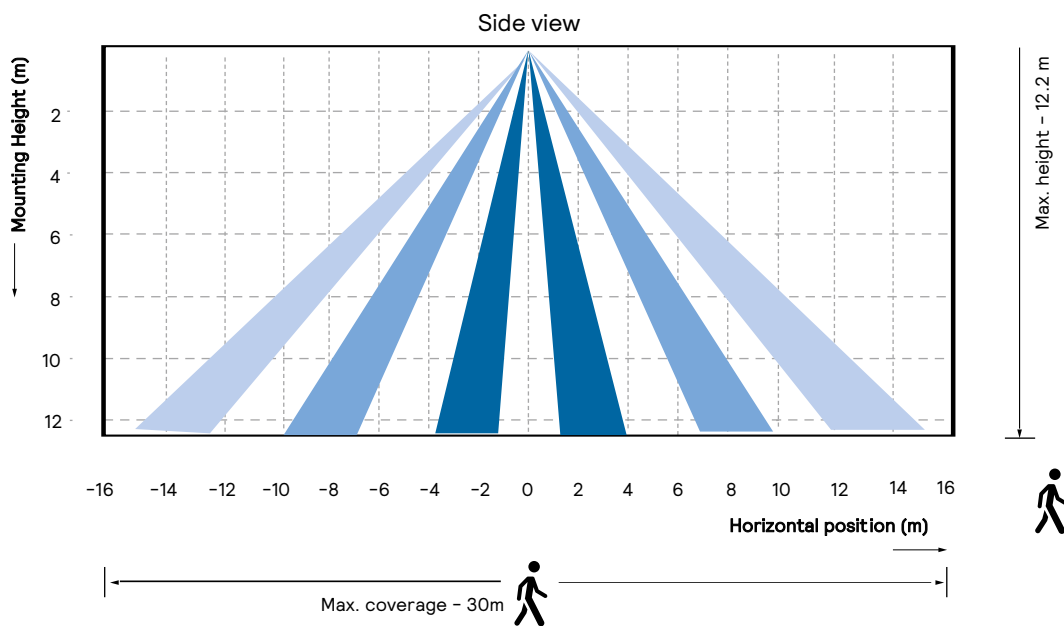

Warning:

Place heat radiating devices outside of the monitoring cone.
Avoid drafts (e.g. from ventilators or heating systems).

EasyAir SNM212 MC

Daylight sensor

The light sensor measures the total amount of light with an opening angle of 55° whereas PIR has 51°, all calculated from normal. The following aspects should be observed during installation:

- Minimum distance from the window - refer below graph
- Sensor should not be mounted lower than the top of the window
- Prevent light reflections from outside entering the sensor (for example sunlight reflection from a car/truck bonnet) as this will lead to incorrect light regulation.

As a guideline the formula $0.8 \times H$ can be used to calculate the minimum horizontal distance between the window and sensor whereby H is the height measured from the bottom of the window to the sensor.

Photosensor spatial response

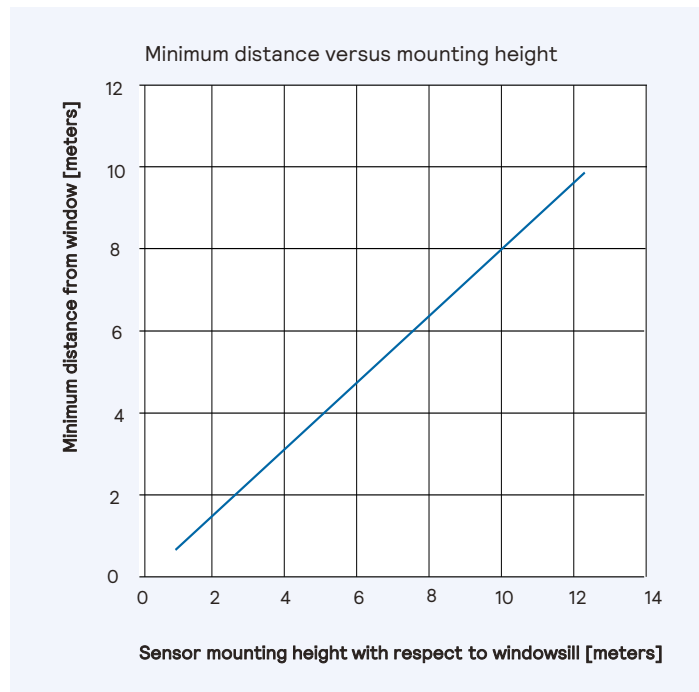
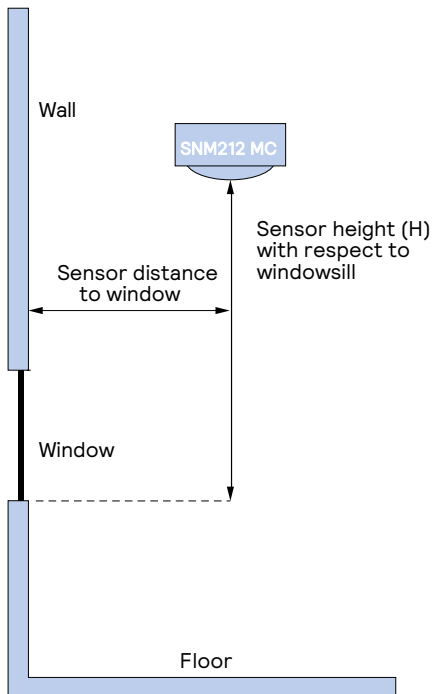

Photosensor spectral response

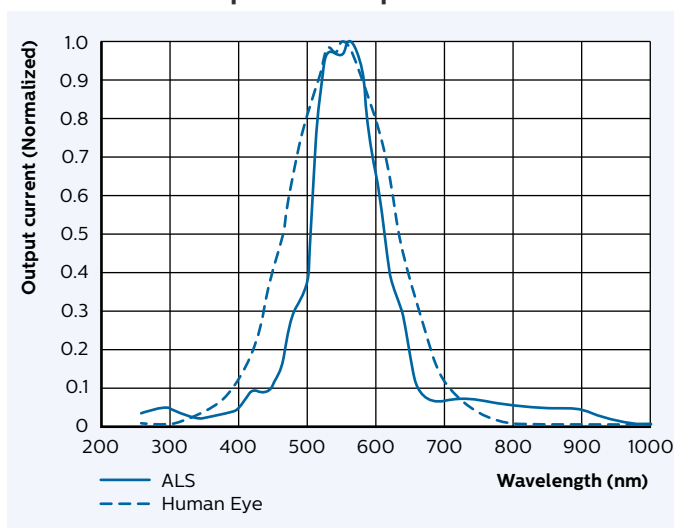

EasyAir SNM212 MC

Philips MasterConnect app

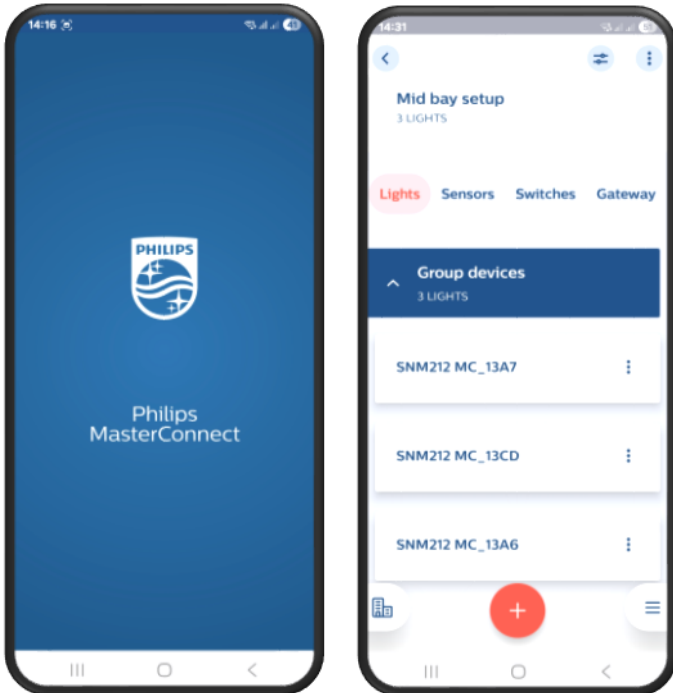

EasyAir SNM212 MC parameters can be commissioned and configured with the Philips MasterConnect app.

This app allows grouping of luminaires and adding switches along with easy configuration of EasyAir SNM212 MC parameters.

Download Philips MasterConnect app from the Google Play Store or the Apple App Store. For details see the app manual on our website:

https://www.lighting.philips.com/prof/led-electronics/masterconnect-system/masterconnect-sensors/LP_CF_9218075_EU/family

Default factory settings

Occupancy based control	Enabled
Daylight Based Control	Enabled
Occupancy Mode	Auto-on/off
Group/Zone Occupancy Sharing	Enabled
Group/Zone Lighting Behaviour	Background level
Zone Occupancy Sharing	Disabled
Field Task Tuning	100%
Eco-On Level	100%
Background Light Level	20%
Hold Time	10 minutes
Prolong Time	10 minutes
Grace Fading	10 seconds
Fade to Switch On	1 second (fixed value)
Fade to Switch Off	1 second (fixed value)

Radio Equipment Directive (RED)

This device meets the EU requirements (2014/53/EU) on the limitation of exposure of the general public to electromagnetic fields by way of health protection. The device complies with RF specifications when the device used at 20cm from your body.

EasyAir SNM212 MC

License notice

This product includes software licensed under terms that require Signify B.V. to display the following notice:

CmBacktrace 1.3

armink/CmBacktrace is licensed under the MIT License (MIT)

Copyright (c) 2016–2019 Armink (armink.ztl@gmail.com)

Permission is hereby granted, free of charge, to any person obtaining a copy of this software and associated documentation files (the 'Software'), to deal in the Software without restriction, including without limitation the rights to use, copy, modify, merge, publish, distribute, sublicense, and/or sell copies of the Software, and to permit persons to whom the Software is furnished to do so, subject to the following conditions:

The above copyright notice and this permission notice shall be included in all copies or substantial portions of the Software.

THE SOFTWARE IS PROVIDED 'AS IS', WITHOUT WARRANTY OF ANY KIND, EXPRESS OR IMPLIED, INCLUDING BUT NOT LIMITED TO THE WARRANTIES OF MERCHANTABILITY, FITNESS FOR A PARTICULAR PURPOSE AND NONINFRINGEMENT. IN NO EVENT SHALL THE AUTHORS OR COPYRIGHT HOLDERS BE LIABLE FOR ANY CLAIM, DAMAGES OR OTHER LIABILITY, WHETHER IN AN ACTION OF CONTRACT, TORT OR OTHERWISE, ARISING FROM, OUT OF OR IN CONNECTION WITH THE SOFTWARE OR THE USE OR OTHER DEALINGS IN THE SOFTWARE.

EasyAir SNM212 MC

MasterConnect

Disclaimer

©2025 Signify Holding B.V. All rights reserved.

Note that the information provided in this document is subject to change.

This document is not an official testing certificate and cannot be used or construed as a document authorizing or otherwise supporting an official release of a luminaire. The user of this document remains at all times liable and responsible for any and all required testing and approbation prior to the manufacture and sale of any luminaire.

The recommendations and other advice contained in this document, are provided solely for informational purposes for internal evaluation by the user of this document. Signify does not make and hereby expressly disclaims any warranties or assurances whatsoever as to the accuracy, completeness, reliability, content and/or quality of any recommendations and other advice contained in this document, whether express or implied including, without limitation, any warranties of satisfactory quality, fitness for a particular purpose or noninfringement. Signify has not investigated, and is under no obligation or duty to investigate, whether the recommendations and other advice contained in this document are, or may be, in conflict with existing patents or any other intellectual property rights. The recommendations and other advice contained herein are provided by Signify on an "as is" basis, at the user's sole risk and expense.

Specifically mentioned products, materials and/or tools from third parties are only indicative and reference to these products, materials and/or tools does not necessarily mean they are endorsed by Signify. Signify gives no warranties regarding these and assumes no legal liability or responsibility for any loss or damage resulting from the use of the information thereto given here.

07/2025

Data subject to change