

### Electrical Specifications at 120-208-240-277V

DIMENSIONS AND DATA		120	208	240	277
<p>4 1/4 X 4 3/4 CORE - 2 COIL UNIT</p> 					
<p>Capacitor: 7C240P40-R</p>  <p>Capacitance: 24 Dia/Oval Dim: 1.75 Height: 4.8 Temp Rating: 105°C</p>					
<p>Ignitor: NA</p> <p>This ballast does not require the use of an ignitor.</p>					
<p>INPUT VOLTS</p> <p>CIRCUIT TYPE CWA</p> <p>POWER FACTOR (min) 90%</p> <p>REGULATION</p> <p>Line Volts ±10%</p> <p>Lamp Watts ±10%</p> <p>LINE CURRENT (Amps)</p> <p>Operating..... 4.00 2.30 2.00 1.75</p> <p>Open Circuit..... 3.00 1.80 1.50 1.35</p> <p>Starting..... 3.25 1.90 1.65 1.45</p> <p>UL TEMPERATURE RATINGS</p> <p>Insulation Class H(180°C)</p> <p>Coil Temperature Code 1029 D E D E</p> <p>MIN. AMBIENT STARTING TEMP. -20°F or -30°C</p> <p>NOM. OPEN CIRCUIT VOLTAGE 305</p> <p>INPUT VOLTAGE AT LAMP DROPOUT..... 50 85 100 120</p> <p>INPUT WATTS 455</p> <p>RECOMMENDED FUSE (Amps)..... 10 7 5 5</p> <p>CORE and COIL</p> <p>Dimension (A) 2.13</p> <p>Dimension (B) 4.00</p> <p>Weight (lbs.) 10.5</p> <p>Lead Lengths 12"</p> <p>CAPACITOR REQUIREMENT</p> <p>Microfarads 24.0</p> <p>Volts (min.) 400</p> <p>Fault Current Withstand (amps)</p> <p>60 Hz TEST PROCEDURES (Refer to Advance Test Procedure for HID Ballasts - Form 1270)</p> <p>High Potential Test (Volts)</p> <p>1 minute 2000</p> <p>2 seconds 2500</p> <p>Open Circuit Voltage Test (Volts) 275-335</p> <p>Short-Circuit Current Test (Amps)</p> <p>Secondary Current 3.40-4.20</p> <p>Input Current..... 2.55-3.80 1.45-2.20 1.30-1.90 1.10-1.65</p>					
<p>Wiring Diagram:</p>  <p>Fig. A1</p>					
Ordering Information					
Order Suffix		Description			
500DA		Ballast w/Dry Film Capacitor			
<p>Data is based upon tests performed by Advance Transformer in a controlled environment and representative of relative performance. Actual performance can vary depending on operating conditions. Specifications are subject to change without notice.</p>					

# Metal Halide 71A6091A

The information presented in this document is not intended as any commercial offer and does not form part of any quotation or contract.

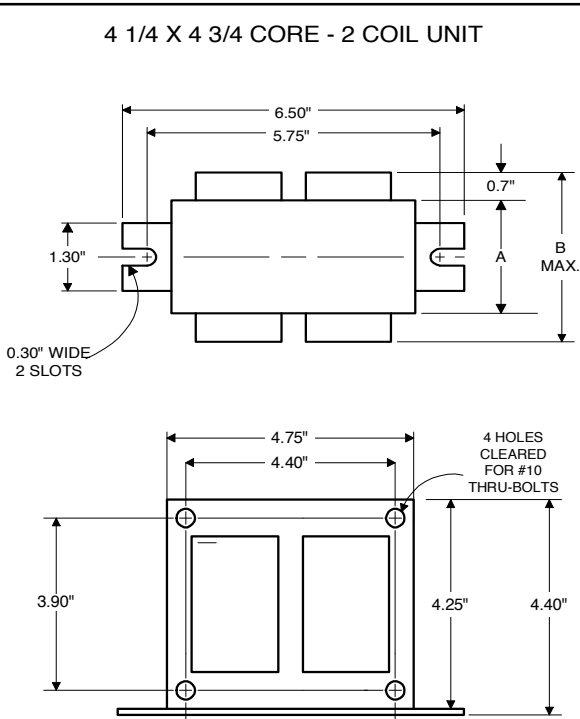
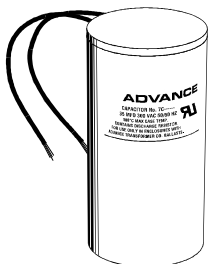
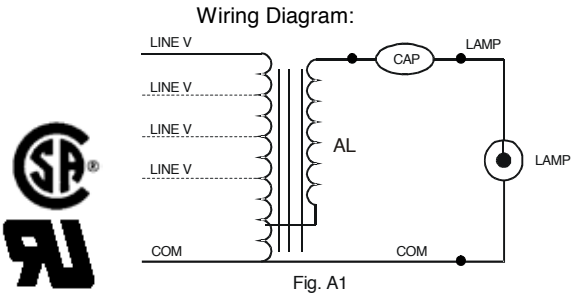

© 2019 Signify Holding. All rights reserved. This document contains information relating to the product portfolio of Signify which information may be subject to change. No representation or warranty as to the accuracy or completeness of the information included herein is given and any liability for any action in reliance thereon is disclaimed. All trademarks are owned by Signify Holding or their respective owners.

Signify North America Corporation  
200 Franklin Square Drive,  
Somerset, NJ 08873  
Telephone 855-486-2216

Signify Canada Ltd.  
281 Hillmount Road,  
Markham, ON, Canada L6C 2S3  
Telephone 800-668-9008