

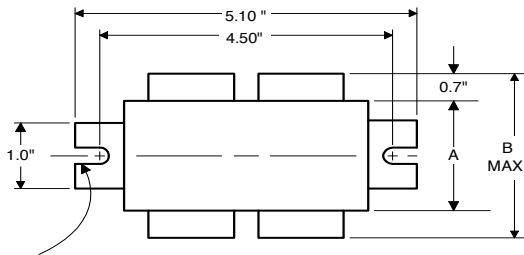

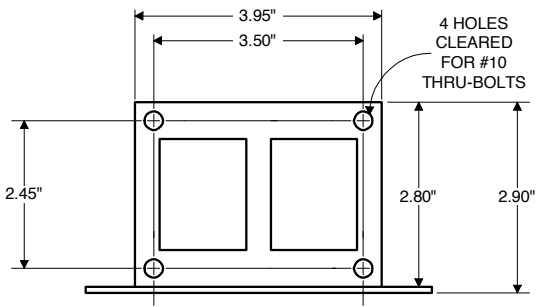

### Electrical Specifications at 120-277-347V

DIMENSIONS AND DATA		120	277	347						
<p><b>3 X 4 CORE - 2 COIL UNIT</b></p>  <p>0.25" WIDE 2 SLOTS</p> 	<p><b>INPUT VOLTS</b></p> <p>CIRCUIT TYPE HX-HPF</p> <p>POWER FACTOR (min) 90%</p> <p>REGULATION</p> <p>Line Volts ±5%</p> <p>Lamp Watts WITHIN TRAPEZOID</p> <p><b>LINE CURRENT (Amps)</b></p> <p>Operating.....</p> <p>Open Circuit.....</p> <p>Starting.....</p>									
	<p><b>UL TEMPERATURE RATINGS</b></p> <p>Insulation Class H(180°C)</p> <p>Coil Temperature Code 1029</p> <p>MIN. AMBIENT STARTING TEMP. -40°F or -40°C</p> <p>NOM. OPEN CIRCUIT VOLTAGE 120</p> <p>INPUT VOLTAGE AT LAMP DROPOUT.....</p> <p>INPUT WATTS 130</p> <p>RECOMMENDED FUSE (Amps).....</p> <p><b>CORE and COIL</b></p> <p>Dimension (A) 2.25</p> <p>Dimension (B) 3.60</p> <p>Weight (lbs.) 7.5</p> <p>Lead Lengths 12"</p> <p><b>CAPACITOR REQUIREMENT</b></p> <p>Microfarads 10.0</p> <p>Volts (min.) 280</p> <p>Fault Current Withstand (amps)</p> <p>60 Hz TEST PROCEDURES (Refer to Advance Test Procedure for HID Ballasts - Form 1270)</p> <p>High Potential Test (Volts)</p> <p>1 minute 2000</p> <p>2 seconds 2500</p> <p>Open Circuit Voltage Test (Volts) 110-130</p> <p>Short-Circuit Current Test (Amps)</p> <p>Secondary Current 2.60-3.20</p> <p>Input Current.....</p>									
<p>Capacitor: 7C100M33-R</p>  <p>Capacitance: 10</p> <p>Dia/Oval Dim: 1.5</p> <p>Height: 2.9</p> <p>Temp Rating: 105°C</p>	<p><b>Wiring Diagram:</b></p>  <p>Fig. K</p>									
<p>Ignitor: LI551-H4</p>  <p>Ballast to Lamp Distance (BTL) = 2 feet</p> <p>Temp Rating: 105°C</p>	<p><b>Ordering Information</b></p> <table border="1"> <thead> <tr> <th>Order Suffix</th> <th>Description</th> </tr> </thead> <tbody> <tr> <td> </td> <td> </td> </tr> </tbody> </table>	Order Suffix	Description							
Order Suffix	Description									
<p>Data is based upon tests performed by Advance Transformer in a controlled environment and representative of relative performance. Actual performance can vary depending on operating conditions. Specifications are subject to change without notice.</p>										

# High Pressure Sodium 71A80A1

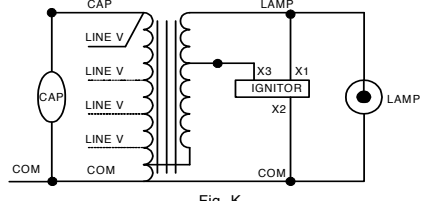
The information presented in this document is not intended as any commercial offer and does not form part of any quotation or contract.



© 2019 Signify Holding. All rights reserved. This document contains information relating to the product portfolio of Signify which information may be subject to change. No representation or warranty as to the accuracy or completeness of the information included herein is given and any liability for any action in reliance thereon is disclaimed. All trademarks are owned by Signify Holding or their respective owners.

Signify North America Corporation  
200 Franklin Square Drive,  
Somerset, NJ 08873  
Telephone 855-486-2216

Signify Canada Ltd.  
281 Hillmount Road,  
Markham, ON, Canada L6C 2S3  
Telephone 800-668-9008