

### Electrical Specifications at 347V

Lamp Type	No. of Lamps	Rated Lamp Watts	Min. Start Temp (°F/C)	Input Current (Amps)	Input Power (ANSI Watts)	Ballast Factor	MAX THD %	Power Factor	MAX Lamp Current Crest Factor	B.E.F.
F17T8	1	17	-20/-29	0.07	23	1.15	15	0.97	2.1	5.11
F17T8	2	17	-20/-29	0.08	27	0.79	10	0.98	1.5	2.95
F25T8	1	25	-20/-29	0.09	30	1.16	10	0.98	2.1	3.83
F25T8	2	25	-20/-29	0.11	38	0.78	10	0.99	1.5	2.05
F32T8	1	32	-20/-29	0.11	38	1.16	10	0.99	2.1	3.04
* F32T8	2	32	-20/-29	0.14	49	0.78	10	0.99	1.4	1.60
F32T8/ES (25W)	1	25	60/16	0.09	32	1.12	10	0.99	2.1	3.52
F32T8/ES (25W)	2	25	60/16	0.12	40	0.77	10	0.99	1.5	1.91
F32T8/ES (28W)	1	28	60/16	0.09	33	1.16	10	0.99	2.1	3.54
F32T8/ES (28W)	2	28	60/16	0.13	43	0.77	10	0.99	1.5	1.78
F32T8/ES (30W)	1	30	60/16	0.10	35	1.12	10	0.99	2.1	3.24
F32T8/ES (30W)	2	30	60/16	0.13	45	0.77	10	0.99	1.5	1.71
F40T8	1	40	32/00	0.13	46	1.21	10	0.99	2.1	2.66

### Enclosure

	(")	(in.)	(cm.)
Overall (L)	9.5"	9 1/2	24.1 cm
Width (W)	1.3"	1 3/10	3.3 cm
Height (H)	1"	1	2.5 cm
Mounting (M)	8.9"	8 9/10	22.6 cm

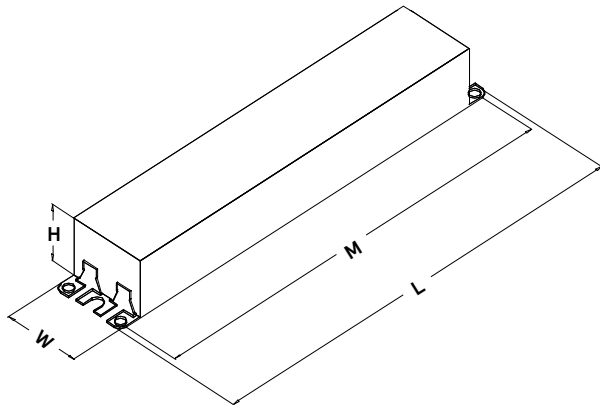

### Wiring Diagram

	(in.)	(cm.)		(in.)	(cm.)
Black	24	61	Yellow/Blue		0
White	24	61	Blue/White		0
Blue	28	71.1	Brown		0
Red	43	109.2	Orange		0
Yellow		0	Orange/Black		0
Gray		0	Black/White		0
Violet		0	Red/White		0

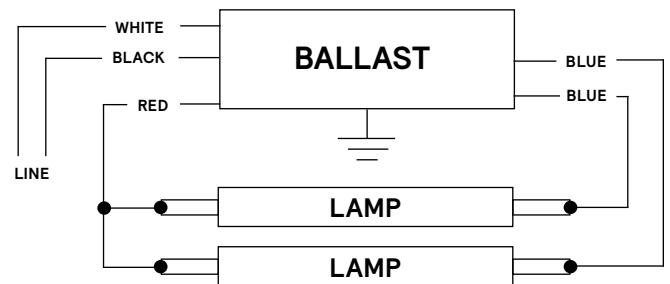

Diag. 64

The wiring diagram that appears above is for the lamp type denoted by the asterisk \* (F32T8).

# Optanium GOPA2P32LWN

## Physical Characteristics

- 1.1 Ballast shall be physically interchangeable with standard electro-magnetic or standard electronic ballasts, where applicable.
- 1.2 Ballast shall be provided with integral leads color-coded per ANSI C82.11.

## Performance

- 2.1 Ballast shall be \_\_\_\_\_ (Instant or Programmed) Start.
- 2.2 Ballast shall provide Independent Lamp Operation (ILO) for Instant Start or Programmed Start Parallel ballasts allowing interference remaining lamp(s) to maintain full light output when one or more lamps fail.
- 2.3 Ballast shall contain auto restart circuitry in order to restart lamps without resetting power.
- 2.4 Ballast shall operate from 50/60 Hz input source of \_\_\_\_\_ (120V through 277V or 347V) with sustained variations of +/- 10% (voltage and frequency).
- 2.5 Ballast shall be high frequency electronic type and operate lamps at a frequency between 42 kHz and 52 kHz to avoid interference with infrared devices, eliminate visible flicker and avoid Article Surveillance System, such as anti-theft devices.
- 2.6 Ballast shall have a Power Factor greater than 0.98 for primary lamp.
- 2.7 Ballast shall have a minimum ballast factor for primary lamp application as follows: 0.77 for Low Watt, 0.87 for Normal Light Output, and 1.18 for High Light for Instant Start ballasts or 0.71 for Low Watt and 0.88 for Normal Light Output for Programmed Start ballasts.
- 2.8 Ballast shall provide for a Lamp Current Crest Factor of 1.7 or less when operating the maximum number of primary lamps.
- 2.9 Ballast input current shall have Total Harmonic Distortion (THD) of less than 10% when operated at nominal line voltage with primary lamp.
- 2.10 Ballast shall have a Class A sound rating for all 4-foot lamps and smaller.
- 2.11 Ballast shall have a minimum starting temperature of -29C (-20F) on Instant Start ballasts or -18C (0F) on Programmed Start ballasts for standard T8 lamps and 16C (60F) for energy-saving T8 lamps. Consult lamp manufacturer for temperature versus light output characteristics.
- 2.12 Ballast shall tolerate sustained open circuit and short circuit output conditions.
- 2.13 Ballast shall have lamp striation-reduction circuitry.
- 2.14 Programmed Start ballast shall provide lamp EOL protection circuitry.
- 2.15 Maximum distance for Energy Saving Lamps in Remote/Tandem wiring applications shall be 6 feet for Instant Start and Programmed Start models.

GOPA2P32LWN	
Brand Name	OPTANIUM
Ballast Type	Electronic
Starting Method	Instant Start
Lamp Connection	Parallel
Input Voltage	347
Input Frequency	50/60 HZ
Status	Active

## Regulatory

- 3.1 Ballast shall not contain any Polychlorinated Biphenyl (PCB).
- 3.2 Ballast shall be Underwriters Laboratories (UL) listed, Class P and Type 1 Outdoor; and Canadian Standards Association (CSA) certified where applicable.
- 3.3 Ballast shall comply with ANSI C62.41 Category A for Transient protection.
- 3.4 Ballast shall comply with ANSI C82.11 where applicable.
- 3.5 Ballast shall comply with applicable requirements of the Federal Communications Commission (FCC) rules and regulations, Title 47 CFR part 18, for Non-Consumer equipment.
- 3.6 Ballast shall meet NEMA Premium/CEE High Performance T8 Lighting System Specifications.
- 3.7 IOP or GOP ballast shall comply with UL Type CC rating.
- 3.8 Ballast shall comply with NEMA 410 for in-rush current limits.
- 3.9 Ballast shall meet RoHS Compliance Standards

## Other

- 4.1 Ballast shall be manufactured in an ISO 9001 Qualified factory.
- 4.2 Ballast shall carry a five-year warranty from date of manufacture against defects in material or workmanship, including replacement, for operation at a maximum case temperature of 70C. Ballasts with a "90C" designation in their catalog number shall also carry a three-year warranty at maximum case temperature of 90C.
- 4.3 Manufacturer shall have a twenty-year history of producing electronic ballasts for the North American market.
- 4.4 Energy-saving T8 lamps (25W, 28W or 30W) may experience lamp striations if operated on ballasts not rated for their use.

The information presented in this document is not intended as any commercial offer and does not form part of any quotation or contract.



© 2021 Signify Holding. All rights reserved. The information provided herein is subject to change, without notice. Signify does not give any representation or warranty as to the accuracy or completeness of the information included herein and shall not be liable for any action in reliance thereon. The information presented in this document is not intended as any commercial offer and does not form part of any quotation or contract, unless otherwise agreed by Signify.

Signify North America Corporation  
200 Franklin Square Drive,  
Somerset, NJ 08873  
Telephone 855-486-2216

Signify Canada Ltd.  
281 Hillmount Road,  
Markham, ON, Canada L6C 2S3  
Telephone 800-668-9008

All trademarks are owned by Signify Holding or their respective owners.