

**PHILIPS**

PowerBalance Elite

 Smart

 Scalable

 Sustainable

**interact** ready.



**Future ready** your  
business with **smart**  
**office lighting**

# Professionals **count** on the **new** **PowerBalance Elite**

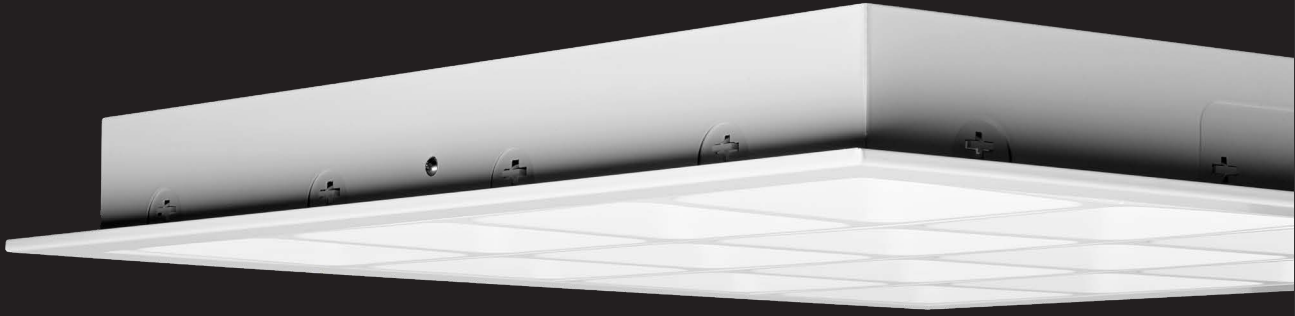

Whether you're looking to reduce energy costs or improve your building's lighting flexibility, PowerBalance is all you need to create a first class LED lighting installation. By balancing horizontal and vertical brightness and combining it with low glare, PowerBalance creates an attractive environment in which both the entire space, plus the individual workspaces are perfectly lit.

Lighting controls play an important part in providing complete office lighting solutions. Signify is able to offer both Wireless and Wired scalable solutions such as Dali and Zigbee connectivity. See page 4 for more information

- ✓ High quality CRI 90 / R9  $\geq$  50 LED chips with SDCM 3 specification ensure the best colour quality and minimal colour shift
- ✓ Choice of 2 lumen outputs per colour temperature to suit all office needs
- ✓ Multiple choices of control interfaces are available to make lighting control simple
- ✓ Three colour temperature options are available to enhance the working environment
- ✓ Best in class luminaire efficacy of 135lm/W, ensures the lowest TCO payback

 • 135lm/W efficacy

 • 100,000hrs at L70

 • Dali  
• Connected  
• Interact Pro  
• Tunable White

 • IP20

 • CRI 90 / R9  $\geq$  50  
• COI compliant

Open Plan Offices

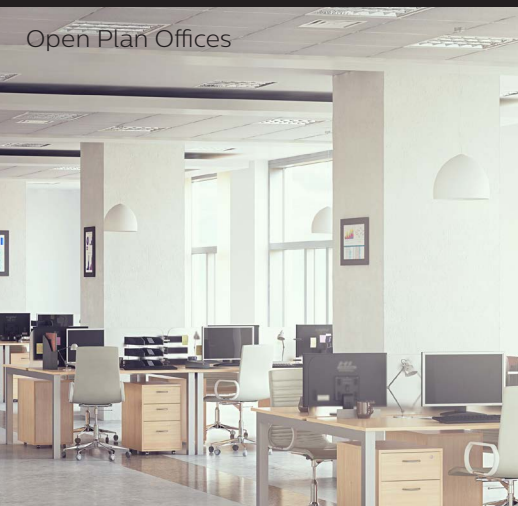

Meeting Rooms



Lecture Theatres



# Specifications

MODEL	POWERBALANCE (RC650B X)					
Type	LED30	LED29	LED25	LED40	LED38	LED33
Power (PSD)	22W	22W	22W	29W	29W	29W
System Lumens	3000lm	2900lm	2500lm	4000lm	3800lm	3350lm
System Efficacy	136lm/W	132lm/W	114lm/W	138lm/W	131lm/W	115lm/W
Colour Temperature	4000K	3500K	3000K	4000K	3500K	3000K
Size (mm)	1,200x300 & 600x600					
Mounting	Recessed					
Input Voltage	220-240V					
Electrical Class	I					
Driver Type	PSD-Dali, WIA-Wireless, SR-System Ready, Tunable White DALI 209 (DALI Type 8)					
Driver Lifetime	**100,000hrs / max 10% Failures					
Electrical Connection	1.5m pre-wired flex & plug (CAU)					
Lumen Maintenance	100,000hrs/L70 - 65,000hrs/L80 - 50,000hrs/L85 - (Based on TM21 Calculations)					
SDCM	<3					
CRI	CRI 90 / R9 ≥ 50, Cyanosis Observation Compliant					
IP Rating	IP20					
UGR Rating	UGR19					
Optical Type	Smart Pyramid Optics					
Finish	White (RAL 9003)					
Warranty	5 Years					

\* Tunable White Available Q2 2020 \*\* Based on PSD-Dali model

## Flicker free

Philips Office Elite Products utilise industry best LED drivers that deliver flicker<sup>1</sup> free performance and no stroboscopic effect<sup>2</sup>.

<sup>1</sup> Additionally the Dali standard specifies 8 bit (256 discrete light levels) that can introduce the appearance of Flicker during transitions (dynamic dimming). Dimming performance is improved with Elite Luminaires by the addition of further bits totalling 32,000 (15bit). These interpolated dimming levels protect against flicker artefacts during light level transitions.

<sup>2</sup> In the absence of compulsory standards Philips Lighting opted to use the accepted test methods according to IEC TR 61547-1 [1] (Flicker) and IEC TR 61547-1 [5] (Stroboscopic Effect) with the following limits: PstLM ≤ 0.5 and SVM ≤ 1.

## Polar intensity

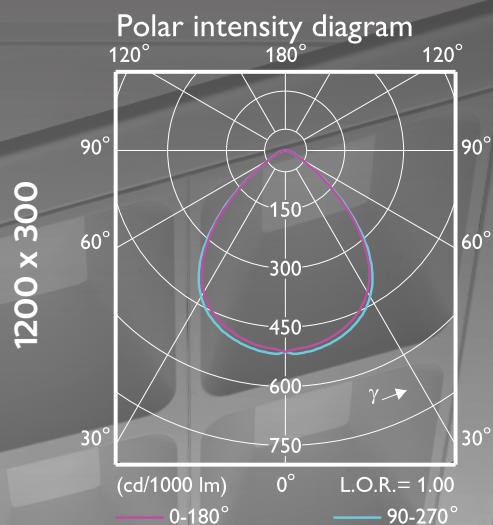
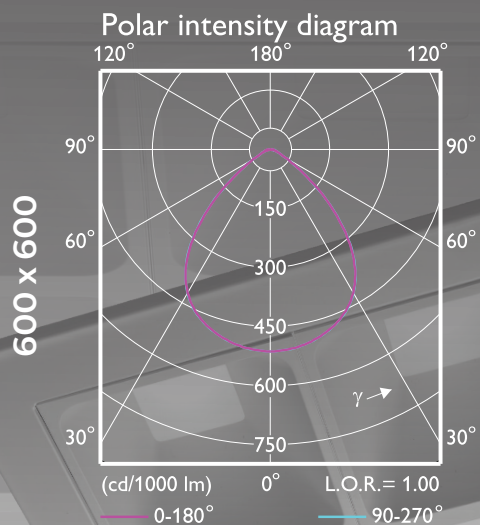





# Control Options

## Dali

A reliable constant current Dali Driver is supplied standard with the PowerBalance Elite to provide stable lumen output and light quality that lighting specifiers and architects demand. The dimming range is between 1-100%, the nominal life is 100,000 hours, and the driver interfaces with DALI and Touch & Dim control systems.

## Lighting control made easy with Dynalite

The Philips Dynalite control platform benefits from 30 years of experience in delivering superior lighting control solutions. Dynalite manages all DALI luminaires, Tunable White recipes to create better environments, and occupancy strategies to maximise the efficiency of workspaces. This takes place seamlessly through multiple control components and the distributed intelligence defining relationships within the system architecture. Reporting and monitoring of the network via Dynalite System Manager software not only provides insights into the operation but also DALI reporting - giving the client the necessary tools to effectively manage the intelligent building.

## Tunable WHITE (Dali 208/209)

Human Centric Lighting can lead to enhanced concentration and increased productivity. When indoor lighting is matching natural circadian rhythms, this can enhance a sense of well-being, and Melanopic Light can be shown to improve sleep patterns. The CCT range is (2700°k to 6500°k). The Tunable White concepts are set to revolutionise the way we work.

## interact Pro scalable system

Connectivity is everything...it is everywhere...it is the future



Interact Pro scalable system allows you to safeguard your day 1 investment and scales up easily with your growing business needs, all without reworking your luminaires.

- Truly straightforward
- No restrictions on light points or building size
- Just add a gateway anytime and unlock more capabilities
- No need to change or swap sensors

# Dimensions & Weights

Dimensions shown below are nominal measurements. Slight variations in dimensions may occur in production.

## RC650B W60L60

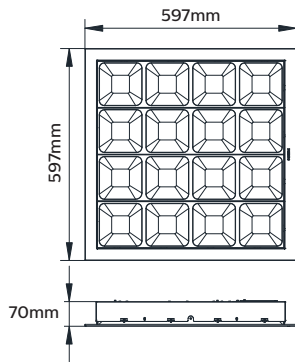

wt. 5.3KG

## RC650B W30L120

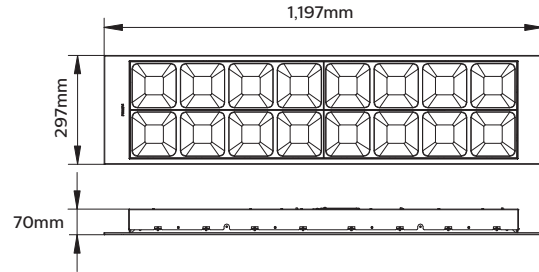

wt. 5.3KG

## Order codes

12NC	Description	Specification
ETO	RC650B LED25S930 PSD W60L60 CAU	Recessed, 22W, 2500lm, 3000K, CRI90, Dali, Square
ETO	RC650B LED25S930 PSD W30L120 CAU	Recessed, 22W, 2500lm, 3000K, CRI90, Dali, Rectangle
ETO	RC650B LED33S930 PSD W60L60 CAU	Recessed, 29W, 3350lm, 3000K, CRI90, Dali, Square
ETO	RC650B LED33S930 PSD W30L120 CAU	Recessed, 29W, 3350lm, 3000K, CRI90, Dali, Rectangle
ETO	RC650B LED29S935 PSD W60L60 CAU	Recessed, 22W, 2900lm, 3500K, CRI90, Dali, Square
ETO	RC650B LED29S935 PSD W30L120 CAU	Recessed, 22W, 2900lm, 3500K, CRI90, Dali, Rectangle
ETO	RC650B LED38S935 PSD W60L60 CAU	Recessed, 29W, 3800lm, 3500K, CRI90, Dali, Square
ETO	RC650B LED38S935 PSD W30L120 CAU	Recessed, 29W, 3800lm, 3500K, CRI90, Dali, Rectangle
ETO	RC650B LED30S940 PSD W60L60 CAU	Recessed, 22W, 3000lm, 4000K, CRI90, Dali, Square
ETO	RC650B LED30S940 PSD W30L120 CAU	Recessed, 22W, 3000lm, 4000K, CRI90, Dali, Rectangle
911401558161	RC650B LED40S940 PSD W60L60 CAU	Recessed, 29W, 4000lm, 4000K, CRI90, Dali, Square
911401558361	RC650B LED40S940 PSD W30L120 CAU	Recessed, 29W, 4000lm, 4000K, CRI90, Dali, Rectangle
ETO	RC650B LED45S940 PSD W60L60 TWN CAU	Recessed, 36W, 4500lm, 208/209 Tunable White, CRI90, Dali, Square
ETO	RC650B LED45S940 PSD W30L120 TWN CAU	Recessed, 36W, 4500lm, 208/209 Tunable White, CRI90, Dali, Rectangle
TBA	RC650X LED40/940 W30L120 WIA CAU	PowerBalance Elite, Recessed, 4000lm, CRI90, 4000K, 300x1,200mm, Interact Ready, no sensor, flex & plug
TBA	RC650X LED40/940 W60L60 WIA CAU	PowerBalance Elite, Recessed, 4000lm, CRI90, 4000K, 600x600mm, Interact Ready, no sensor, flex & plug



© 2021 Signify Holding. All rights reserved. Signify reserves the right to make changes in specifications and/or to discontinue any product at any time without notice or obligation and will not be liable for any consequences resulting from the use of this publication. Application images shown may not reflect actual products advertised.

Version: December 2021

**Signify New Zealand Limited**

Level 3, 123 Carlton Gore Road  
Newmarket, Auckland 1023  
New Zealand  
T: 0800 454 448 / 0800 4 LIGHT

[lighting.philips.co.nz](http://lighting.philips.co.nz)

**Signify Australia Limited**

65 Epping Road, North Ryde  
NSW 2113  
Australia  
T: 1300 110 500

[philips.com.au/lighting](http://philips.com.au/lighting)