

**PHILIPS**

Lighting



## UNISTREET GEN2 MICRO

**BGP281 LED-HB/740 II DM32 6650 lm**

### Introduction

Designed for large-scale ledification projects, the UniStreet gen2 is the ideal 1:1 luminaire replacement for municipalities. Thanks to its high efficiency and low initial cost, the UniStreet gen2 luminaire enables a fast payback and significant savings in terms of energy consumption within a short period of time. The ease of installation and maintenance is enabled by the Philips Service tag and the Philips SR (System Ready) socket makes it future-ready and you can pair this luminaire with lighting control and software applications such as Interact City.; Available with a number of different optics and lumen packages that can even be tuned further to fit exact project requirements, UniStreet gen2 is a true point-to-point replacement solution for conventional light sources. The compact luminaire, using high-quality materials is also easy to dismantle and recycle at the end of its lifetime.

## Product Information

<b>Product Family Code</b>	BGP281
<b>Mechanical and Housing</b>	
<b>Housing Material</b>	Aluminum die cast
<b>Fixation material</b>	Aluminum
<b>Ingress protection code</b>	IP66
<b>Mech. impact protection code</b>	IK08
<b>Corrosion resistance</b>	500 hours Salt Spray Test for standard version, 1.000 hours. Salt Spray Test optional Marine Salt Protection (MSP)
<b>Certification</b>	
<b>CE mark</b>	CE mark
<b>ENEC mark</b>	ENEC plus mark
<b>RoHS mark</b>	-
<b>WEEE mark</b>	-
<b>Protection class IEC</b>	II
<b>Service</b>	
<b>Warranty period</b>	5 years
<b>Serviceability</b>	Class A, luminaire is equipped with serviceable parts (when applicable): LED board, driver, control units, surge protection device, optics, front cover and mechanical parts
<b>Light source replaceable</b>	Yes
<b>Operating ambient temperature range Tamb</b>	-40 to +50 °C
<b>Performance ambient temperature (Tq)</b>	25 °C
<b>L-Value</b>	L90
<b>Lifetime</b>	100000 h
<b>Surge protection</b>	6KV in Common or Differential mode as standard, 10KV with optional Surge Protector Device (SPD)

### IPEA - Energy classification

Road		Large area		Historical centers		Green areas		Cycle & pedestrian	
IPEA	Class	IPEA	Class	IPEA	Class	IPEA	Class	IPEA	Class
1.93	A8+	2.02	A9+	2.35	A12+	1.88	A7+	1.88	A7+

**Dimensional drawing(s) - mm**

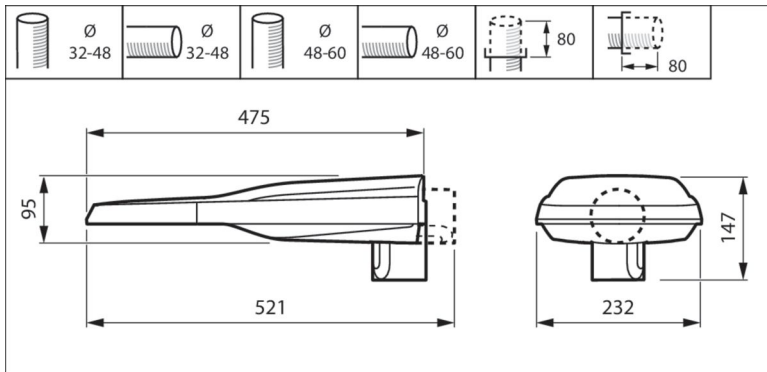

**Additional text**

*Optical cover/lens material: Tempered glass*

# Light technical Report

## Drivers

<b>Description</b>	Xi FP 75W 0.3-1.0A SNLDAE 230V C133 sXt
<b>12NC</b>	929002872906
<b>Number of driver(s)</b>	1
<b>Number of driver per MCB 16A</b>	10
<b>Inrush current</b>	43 A
<b>Inrush time</b>	260 $\mu$ s
<b>Input Voltage</b>	220V-240V
<b>Input Frequency</b>	50/60 Hz
<b>Current</b>	677 mA
<b>System power (minimum)</b>	43 W
<b>System power (maximum)</b>	43 W
<b>System power (average)</b>	43 W
<b>Power consumption tolerance</b>	+/-10%
<b>Power Factor (100%)</b>	0.98
<b>Power Factor (50%)</b>	0.94
<b>Connectivity</b>	No connectivity
<b>Dimming</b>	No dimming

## Light engine

<b>Light source engine type</b>	LED
<b>Number of LED</b>	20
<b>Initial LED luminaire efficacy (source)</b>	155 lm/W
<b>Initial LED luminaire efficacy (system)</b>	141 lm/W
<b>Light source colour</b>	740 (Neutral White)
<b>Init. colour Rendering Index</b>	70
<b>Init. CRI tolerance</b>	+/-2
<b>Init. Corr. colour Temperature</b>	4000 K
<b>Initial tolerance</b>	+/- 180 K (5 SDCM)
<b>End of life tolerance</b>	+/- 255 K
<b>Initial luminous flux (source)</b>	6650 lm
<b>Luminous flux tolerance</b>	+/-7%
<b>Initial luminous flux (system)</b>	6068 lm
<b>Photobiological risk</b>	Risk group 0 (exempt) according to EN IEC 62471

## Optics

<b>Optical configuration</b>	DM32
<b>LOR</b>	0.91
<b>ULR at tilt=0°</b>	0.00%
<b>G* at tilt=0°</b>	G*4
<b>Imax (at 90° and above)</b>	0 cd/klm
<b>CIE code</b>	37 77 99 100 91

## Dimming range

Current percentage	Current (mA)	System power (minimum) (W)	System power (maximum) (W)	System power (average) (W)	Source flux (lm)	System flux (lm)
100	677	43	43	43	6650	6068
95	644	41	41	41	6372	5815
90	610	39	39	39	6085	5553
85	576	37	37	37	5792	5285
80	542	34.5	34.5	34.5	5494	5014
75	508	32.5	32.5	32.5	5191	4737
70	474	30.5	30.5	30.5	4883	4456
65	441	28.5	28.5	28.5	4569	4169
60	407	26.5	26.5	26.5	4251	3879
55	373	24.5	24.5	24.5	3927	3584
50	339	22.5	22.5	22.5	3599	3284
45	305	20.5	20.5	20.5	3267	2981
40	271	18.4	18.4	18.4	2930	2674
35	237	16.4	16.4	16.4	2588	2362
30	204	14.2	14.2	14.2	2242	2046
25	170	12.4	12.4	12.4	1892	1727
20	136	10.6	10.6	10.6	1537	1403
15	102	8.4	8.4	8.4	1179	1076

# Maintenance factor

Maintenance factor according ISO/CIE 22012 TS (2019)

The maintenance factor MF is determined using:

$$MF = LLMF \cdot SF \cdot LMF \cdot SMF$$

where

LLMF is the luminous flux factor

SF is the survival factor (=1 due to spot replacement regime)

LMF is the luminaire maintenance factor

SMF is the surface maintenance factor (=1 for outdoor lighting)

MF for 100000 hours (24.4 years) = 0.78

With

LLMF = 0.9

LMF = 0.87

and based on a cleaning cycle of 1 years and 4100 burning hours / year

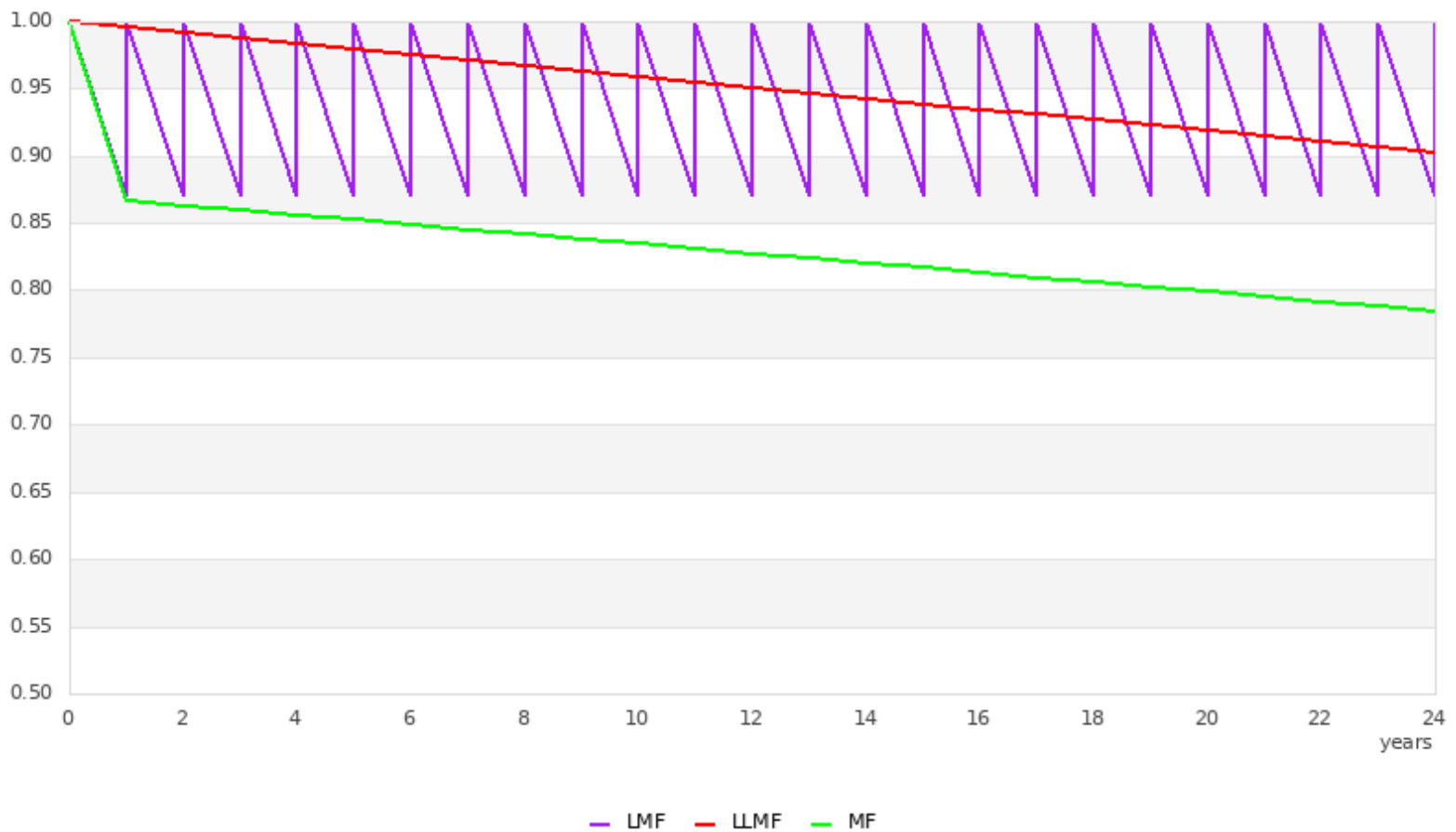





# Photometric Graphs

## Polar intensity diagram

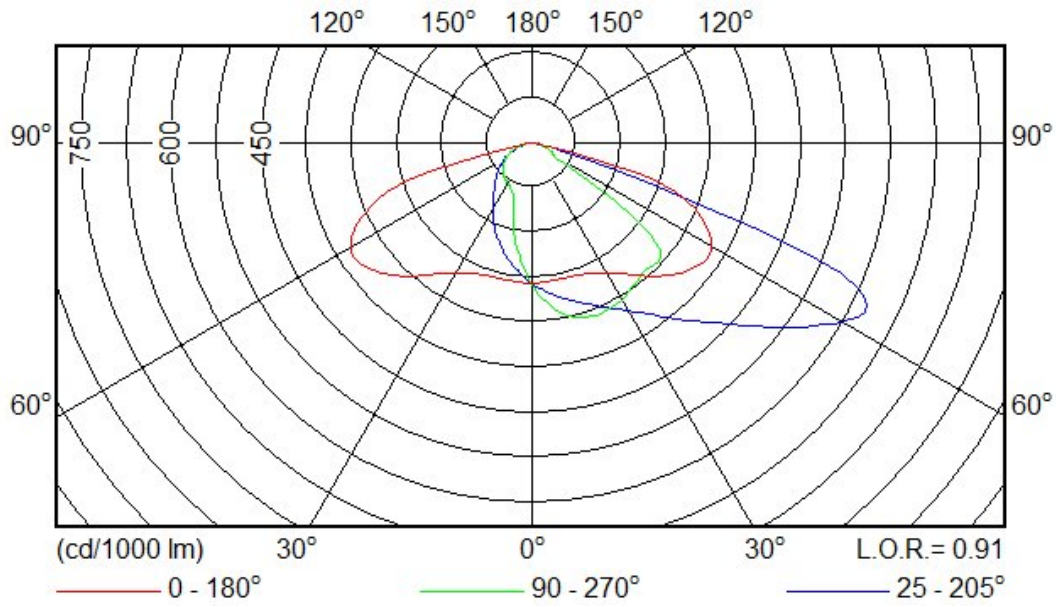

## Utilisation factor curve and luminance yield diagram    Relative isolux diagram

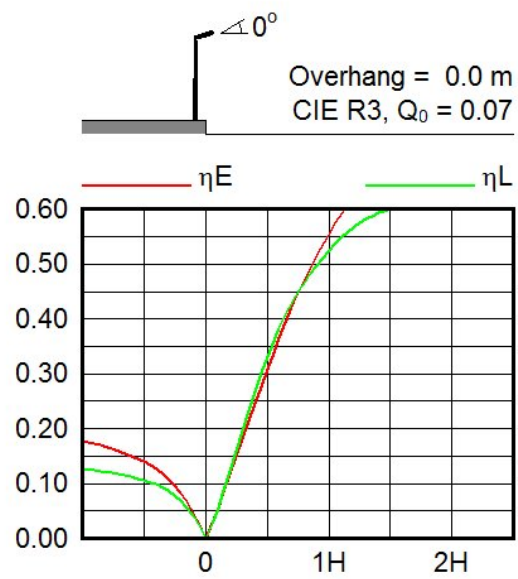

Horizontal Illuminance  $\triangle 0^\circ$

H (m)	$E_{max}$ (lux)
4.0	114
6.0	51
8.0	29

M.F. = 1.0

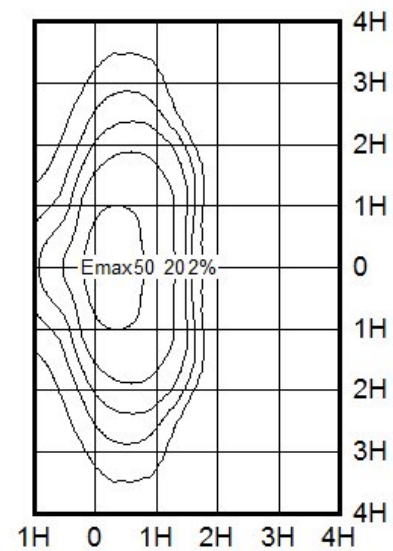

# Lab Information & Certification

## Lab Information

### Test standards

<b>EN 13032-4:2015</b>	Light and lighting. Measurement and presentation of photometric data of lamps and luminaires. Part 4: LED lamps, modules and luminaires
<b>EN 13032-1:2014</b>	Light and lighting. Measurement and presentation of photometric data of lamps and luminaires. Part 1: Measurement and file format
<b>IEC 62717:2014+AMD1:2015</b>	LED modules for general lighting - performance requirements
<b>IES LM-79-08</b>	IES Approved Method: Electrical and Photometric Measurements of Solid-State Lighting Products
<b>IEC / EN 62722-1:2014</b>	Luminaire performance - Part 1: General requirements
<b>IEC / EN 62722-2-1:2014</b>	Luminaire performance - Part 2-1: Particular requirements for LED luminaires

### Test equipment

LMT GO-DS 2000 Goniometer (C/G)	<input type="checkbox"/>
Yokogawa WT3000 power analyzer	<input type="checkbox"/>
Chroma 6415 programmable AC source	<input type="checkbox"/>
Agilent 6675A system DC power supply	<input type="checkbox"/>
Integrating sphere U-101-A	<input type="checkbox"/>
EM TEST NetWave3 AC/DC source	<input type="checkbox"/>
FLUKE Norma 4000 power analyzer	<input type="checkbox"/>
Sonopan L-100 luxmeter	<input type="checkbox"/>
Gigahertz X1-3 hazard lightmeter	<input type="checkbox"/>
Gigahertz XD-45-HB-4 Head	<input type="checkbox"/>
Gigahertz XD-45-HUV-4 head	<input type="checkbox"/>

### MEASUREMENT UNCERTAINTIES

Type of test	Uncertainties
Luminous flux	+/- 2.2 %
Power	+/- 0.5 %
Imax	+/- 2.2 %
Beam angle of Imax	+/- 0.1°
Ambient temperature 0-50°C	+/- 0.1°C

.....  
Signed-off by  
Dariusz Pierzchanowski

**DISCLAIMER:** This photometry report is compiled based on real measurement done in Signify Laboratories during development and release of new products and calculation data pulled from PPS web-based tool and internal data. The values present in this report may differ from real values measured for specific product, but not more than +/-10 % on power and +/- 7% on lumen.

Certification



# APPENDIX TO CERTIFICATE

SMT/CTF-3/0001/3/2018

## Supervised Manufacturers' Testing SMT Customer's Testing Facility CTF - Stage 3

### List of products

for which the Laboratory of Quality Philips Lighting Poland Sp. z o.o. Pila O/Kętrzyn  
is authorized to perform testing  
for ITE PREDOM Division as a certification body in the framework  
ENEC an CCA agreements and IECEE CB Scheme

CATEGORY	PRODUCTS*)	STANDARDS**)		
		For ENEC and CCA	For IECEE CB Scheme	For national certification
LITE	Fixed general purpose luminaires	EN 60598-1 EN 60598-2-1	IEC 60598-1 IEC 60598-2-1	EN 60598-1 EN 60598-2-1
LITE	Recessed luminaires	EN 60598-1 EN 60598-2-2	IEC 60598-1 IEC 60598-2-2	EN 60598-1 EN 60598-2-2
LITE	Luminaires for road and street lighting	EN 60598-1 EN 60598-2-3	IEC 60598-1 IEC 60598-2-3	EN 60598-1 EN 60598-2-3
LITE	Floodlights	EN 60598-1 EN 60598-2-5	IEC 60598-1 IEC 60598-2-5	EN 60598-1 EN 60598-2-5
LITE	Luminaires for emergency lighting	EN 60598-1 EN 60598-2-22	IEC 60598-1 IEC 60598-2-22	EN 60598-1 EN 60598-2-22
LITE	Luminaires with limited surface temperatures	EN 60598-1 EN 60598-2-24	IEC 60598-1 IEC 60598-2-24	EN 60598-1 EN 60598-2-24
LITE	LED modules for general lighting	EN 62031	IEC 62031	EN 62031
LITE (ENEC+)	LED modules for general lighting	EPRS 001/ IEC 62717	-	-
LITE (ENEC+)	Luminaires	EPRS 002 / IEC 62722-1	-	-
LITE (ENEC+)	LED Luminaires	EPRS 003/ IEC 62722-2-1	-	-
LITE	Lamp and luminaires	-	-	EN 13032-1
LITE	Lamp and luminaires	-	-	EN 13032-2
LITE	Lamp and luminaires	-	-	EN 13032-3
LITE	LED lamps, modules and luminaires	-	-	EN 13032-4
LITE	Solid-State Lighting Products	-	-	LM-79

\*) - Name and address of manufacturing place of the products: Philips Lighting Poland Sp. z o.o. Pila, ul. Kossaka 150, O/Kętrzyn ul. Chrobrego 8, 11-400 Kętrzyn, Poland

\*\*) - newest edition of the standards/documents

Manager of Certification Office  
ITE PREDOM Division

Joanna Walczak- Zlotkowska

Deputy Director of ITE PREDOM Division

Aleksander Piotrowski

Warsaw, 2018-11-28



Instytut Technologii Elektronowej Oddział PREDOM  
Institute of Electron Technology PREDOM Division  
ul. Krakowiaków 53, 02-255 WARSZAWA, POLSKA - POLAND

**POLSKIE CENTRUM AKREDYTACJI**  
POLISH CENTRE FOR ACCREDITATION



Sygnatariusz EA MLA  
EA MLA Signatory

**CERTYFIKAT AKREDYTACJI**  
**LABORATORIUM BADAWCZEGO**  
ACCREDITATION CERTIFICATE OF TESTING LABORATORY  
**Nr AB 003**

Potwierdza się, że: / This is to confirm that:

**INSTYTUT TECHNOLOGII ELEKTRONOWEJ**  
Al. Lotników 32/46, 02-668 Warszawa  
**INSTYTUT TECHNOLOGII ELEKTRONOWEJ ODDZIAŁ PREDOM**  
**LABORATORIUM BADAWCZE**  
ul. Krakowiaków 53, 02-255 Warszawa

spełnia wymagania normy PN-EN ISO/IEC 17025:2005  
meets requirements of the PN-EN ISO/IEC 17025:2005 standard

Akredytowana działalność jest określona w Zakresie Akredytacji Nr AB 003  
Accredited activity is defined in the Scope of Accreditation No AB 003

Akredytacja pozostaje w mocy pod warunkiem przestrzegania  
wymagań jednostki akredytującej określonych w kontrakcie Nr AB 003  
This accreditation remains in force provided the Laboratory observes  
the requirements of Accreditation Body defined in the Contract No AB 003

Akredytacji udzielono dnia 27.04.1993 r.  
Accreditation was granted on 27.04.1993



DYREKTOR  
POLSKIEGO CENTRUM AKREDYTACJI

  
LUCYNA OLBORSKA

Warszawa, 10 grudnia 2018 roku

# Intensity Table

FORMAT=PHILLUM  
VERSION=2.0  
STATUS=R  
MCO=LVE170908C  
DATE=2018-01-26  
TXTS="L-TUNE 2022-10-05"  
ORIG=WLD  
BRAND=PHILIPS  
FAMILY=UniStreet gen2 Micro  
FAMCOD=BGP281  
HOUSING=BGP281 T25  
OPTICS=DM32  
BLID=-  
LAMP=LED-HB 6650 lm-4S L90@100kh  
LAFLUX=6650  
NLPS=1  
LAMPVOL=740  
INPW=43  
INVO=230  
GEOTYPE=3  
GEOL1=0.095  
GEOL2=0.232  
GEOL3=0.52  
OPTTYPE=3  
OPTL1=0  
OPTL2=0.198  
OPTL3=0.173  
SURF76=0.008  
SURF85=0.003  
PTYP=C  
BANGLE=0.00  
TLME=0.00  
LUBA=1000  
CORR=1  
SYMCON=4  
SYMPANE=4  
NCON=62  
NPLA=145  
CONA= 0 2 4 6 8 10 12 14 16 18 20 22 24 26 28 30 32 34 36 38 40 42 44 46 48 50 52 54 56 58 59 60 61 62 63 64  
65 66 67 68 69 70 71 72 73 74 75 76 77 78 79 80 81 82 83 84 85 86 87 88 89 90  
PLANA= 0 2.5 5 7.5 10 12.5 15 17.5 20 22.5 25 27.5 30 32.5 35 37.5 40 42.5 45 47.5 50 52.5 55 57.5 60 62.5 65  
67.5 70 72.5 75 77.5 80 82.5 85 87.5 90 92.5 95 97.5 100 102.5 105 107.5 110 112.5 115 117.5 120 122.5 125  
127.5 130 132.5 135 137.5 140 142.5 145 147.5 150 152.5 155 157.5 160 162.5 165 167.5 170 172.5 175 177.5 180  
182.5 185 187.5 190 192.5 195 197.5 200 202.5 205 207.5 210 212.5 215 217.5 220 222.5 225 227.5 230 232.5 235  
237.5 240 242.5 245 247.5 250 252.5 255 257.5 260 262.5 265 267.5 270 272.5 275 277.5 280 282.5 285 287.5 290  
292.5 295 297.5 300 302.5 305 307.5 310 312.5 315 317.5 320 322.5 325 327.5 330 332.5 335 337.5 340 342.5 345  
347.5 350 352.5 355 357.5 360  
ITABLE= 234.4 234 233 232.3 232.1 232.1 232.2 232.3 232.5 233.1 234.3 236.1 238.6 241.7 245.3 250 255.6 262.4  
270.2 279 289.3 299.2 308.4 317.5 326.2 333.9 340.9 346.8 350.7 350.9 349.5 347 343.9 339.3 333.6 326.5 318  
308.9 299.5 291 282.7 271.3 254.7 232.4 208.9 177.6 129.1 72.5 28.9 11.8 7.9 5.9 4.2 2.7 1.6 0.9 0.6 0.4 0.2  
0.2 0.2 0  
234.4 234.6 234.3 234.3 234.5 235.2 236.1 236.8 237.5 238.8 240.6 243.3 246.5 250.5 255 260.6 267.2 274.9  
283.9 293.8 305.7 317 328 338.6 348.6 359.8 370.4 380.5 388.4 393.2 394.3 394.3 393 390.8 387 381.4 374.1  
364.5 354.7 345.6 337 326.3 307.9 281.7 256.9 225.7 163.2 83.9 30.8 12.7 7.8 5.8 4 2.5 1.5 0.8 0.5 0.4 0.2  
0.2 0.2 0  
234.4 235.3 235.6 236.1 236.9 238 239.6 240.8 242.2 244 246.4 249.4 253.3 257.9 263.2 269.3 276.6 284.8 294.6  
305.1 318.1 331 343.1 355.5 366.9 379.8 393.2 406.6 419 428.7 432.3 435 436.4 436.6 435.1 431.5 425.6 417.3  
406.8 396 385.3 374.5 358.2 332.3 304.2 272.4 206.6 118.1 52.5 20.6 10 6.5 4.3 2.9 2 1.1 0.7 0.4 0.2 0.2 0.2 0  
234.4 235.6 236.7 237.6 239 240.9 243 245 246.9 249.4 252.4 256.1 260.7 266.1 272 279.2 287.2 296.4 307.2  
318.5 332.8 346.1 359.8 373 385.6 400.7 416.5 433.1 448.5 461.6 467.3 471.6 475 476.3 475.6 472.1 465.8 455.5  
443.1 429.9 416 401.7 380.9 351.2 317.7 270.2 186.4 100.1 45.1 18.9 9.2 6 4 2.5 1.5 1 0.5 0.4 0.2 0.2 0.2 0  
234.4 236.4 237.9 239.7 241.5 243.9 246.4 248.9 251.4 254.3 257.8 262 267.1 272.8 279.3 286.8 295.4 304.9  
316.2 327.9 342.2 356.8 371 385.4 399.1 415.4 433 451.9 470.9 487.9 495.6 502.5 507.9 511.5 512.8 511.2 505.5  
495.8 482.2 465.7 448 429.9 409 380.4 342 298.8 223.7 133.8 65.9 28.8 12.4 7.1 4.6 3 1.8 1.1 0.7 0.4 0.2 0.2  
0.2 0  
234.4 236.9 238.9 241.2 243.7 246.7 249.6 252.7 255.7 259.3 263.2 268.1 273.9 280.2 287.4 295.4 304.4 314.7  
326.8 338.9 353.7 368.7 384 399.2 414.3 432.4 451.9 473.1 494.3 514.1 523.8 531.9 538.8 543.3 544.8 542.5  
535.7 522.8 504.7 484.3 462.4 439.5 411.7 373.5 324.5 276 206.1 119.3 55.1 24.4 10.9 6.7 4.2 2.7 1.5 1 0.5  
0.3 0.2 0.1 0.2 0  
234.4 237.5 240.2 243 246.1 249.5 253.2 256.5 260.1 263.8 268.4 273.6 279.5 286.3 293.7 302 311.2 321.5 333.6  
346.1 360.4 376.4 392.1 408.5 424.8 443.4 464.2 486.8 510.6 533.8 544.9 555.5 564.2 570.6 574 573.6 568.2  
556.4 537.5 513.6 487.1 452.8 421.2 377.6 326.8 277.6 226.9 157.2 85.7 38.4 16.8 8.6 5.6 3.6 2 1.1 0.7 0.4  
0.2 0.2 0.2 0  
234.4 237.9 241.2 244.7 248.2 252.1 256.1 260.1 264.1 268.5 273.4 279.2 285.5 292.6 300.5 309.2 318.7 329.4  
341.7 354.6 369.5 385.7 402.4 419 435.8 456.2 478.8 503 528.1 552.5 564.6 575.6 585.1 591.6 595.2 594.9 588.6  
573.9 550.9 520.5 480.6 434.9 382.7 329.3 271.1 219.2 172.8 122.4 72.4 36.9 16.2 8.5 5.3 3.4 1.8 1 0.6 0.3  
0.2 0.2 0.1 0  
234.4 238.6 242.5 246.4 250.5 254.6 259.1 263.6 268.1 272.8 278 283.9 290.5 297.7 305.5 314.2 323.7 334.1  
346.3 360.3 374.5 391.1 407.1 423.9 442 462.6 485.8 510.2 535.9 561.7 574.2 586.3 597.1 605.9 612.1 614.4  
611.2 599.8 577.1 539.7 485 419.1 352 287.3 225.2 167.9 117.1 80.6 57.1 40.3 25.5 13 6.9 4.3 2.5 1.4 0.8 0.4  
0.2 0.1 0.1 0  
234.4 239 243.6 247.9 252.3 257 261.9 266.8 271.7 276.8 282.3 288.4 295.4 302.9 310.8 319.5 329 339.8 352  
366.7 381 396.8 413.3 430.3 449 471.1 495 520 545.4 570.4 583.1 594.9 606 614.6 620.3 620.5 613.9 595.6 560.4











234.4 228.1 221.1 214.1 207.4 201.1 194.5 187.6 180.4 173.3 166.1 159 151.7 144.1 136.2 128.6 120.8 113.5  
 106.5 100.5 95.2 90.4 85.7 81.2 76.7 71.8 66.9 62.3 57.7 53.4 51.3 49.1 46.9 44.6 42.2 39.8 37.1 33.7 30.6  
 27.7 24.8 21.9 19.3 16.7 14.3 12.5 10.7 9.3 7.8 6.4 5 3.9 2.9 1.9 1.3 0.8 0.5 0.4 0.3 0.2 0.3 0  
 234.4 228.6 222.2 216.1 209.9 204 198.2 192.2 185.8 179.4 173.2 166.8 160.6 154.1 147.2 140.5 133.6 126.9  
 120.2 113.8 108.1 102.9 97.9 92.9 87.9 82.6 77.4 71.9 66.2 61 58.4 55.8 53.6 51 48.5 45.8 43 40 36.6 31.5  
 27.5 23.7 20.7 17.5 15 12.7 10.9 9.4 7.9 6.3 5.2 4.1 3.1 2 1.3 0.8 0.5 0.4 0.3 0.2 0.2 0  
 234.4 229.1 223.5 217.7 212.3 207 201.9 196.4 190.8 185.4 180 174.7 169.3 163.7 158.2 152.6 146.8 141.2 135.3  
 129.5 123.8 118.5 113.1 107.9 102.7 97.2 91.4 84.9 78.2 71.6 68.7 65.7 62.6 59.9 56.9 54.1 51 47.6 43.4 38  
 32.2 26.5 22 18.5 15.4 12.8 10.6 8.7 7.3 6.1 4.9 3.9 2.8 1.7 1.1 0.7 0.5 0.4 0.3 0.2 0.3 0  
 234.4 229.6 224.7 219.7 214.7 210.2 205.6 201 196.1 191.4 187.2 182.7 178.6 174.2 169.9 165.4 161.2 156.9  
 152.6 147.8 142.9 137.6 132.5 127 121.6 116.4 110.3 103.6 95.8 87.6 84 79.6 76 72.2 68.6 65 61.4 57.9 53.9  
 47.9 40.8 33 26.1 21 17.7 15 12.5 10.5 8.5 6.7 5.4 4.2 3.1 2 1.3 0.8 0.5 0.4 0.3 0.2 0.2 0  
 234.4 230.2 225.9 221.4 217 213.3 209.5 205.4 201.3 197.5 194.2 190.7 187.6 184.5 181.5 178.7 175.8 173.2  
 170.6 167.7 164.4 160.1 154.8 149.5 144.6 139.3 132.8 125 116 106.5 101.6 96.5 91.6 87 82.4 78.2 74.3 70.1  
 65.7 59.8 51.6 41 30.8 23 18.2 15.1 12.6 10.5 8.8 7.2 5.6 4.2 2.9 1.8 1.2 0.7 0.5 0.4 0.3 0.2 0.3 0  
 234.4 230.8 227.1 223.1 219.6 216.4 213.2 209.9 206.6 203.6 200.9 198.5 196.5 194.8 192.9 191.5 190.3 189.5  
 188.6 187.7 187.1 184.9 181.2 176.9 172.3 167.4 160.8 152.8 143.1 132.2 126.8 120.5 114.9 108.8 103.5 98.1  
 93.1 88.7 84.4 79.2 72 61.1 47.4 33.8 23.7 17.4 14 11.9 9.7 7.9 6.3 4.8 3.4 2.2 1.4 0.9 0.5 0.4 0.3 0.2 0.2 0  
 234.4 231.5 228.2 225 222.1 219.7 217.2 214.4 211.8 209.6 207.9 206.5 205.4 204.9 204.5 204.6 205.2 206.2  
 207.3 208.9 210.6 210.7 209.5 207.5 204.6 199.6 192.7 184.2 174.1 162.7 156.3 149.6 142.7 135.8 128.9 122.6  
 116.9 111.7 106.6 101.3 93.7 82 65.3 47.3 31.6 20.4 14.6 11.8 9.5 7.8 6.3 4.6 3.2 2 1.3 0.7 0.5 0.4 0.3 0.2  
 0.2 0  
 234.4 232.1 229.4 226.9 224.6 222.7 220.8 219.1 217 215.5 214.5 213.9 213.9 214.3 215 216.4 218.4 221 224.1  
 227.8 231.9 234.9 236.6 237.9 238.6 236.3 231.1 224.1 214.9 203.7 195.8 190 183.1 175 167.3 159.5 152.3 145.9  
 140.1 134 127.5 116.2 100.8 80.6 60.5 38.1 21.2 13.7 10.8 8.7 7 5.3 3.8 2.4 1.4 0.9 0.5 0.4 0.3 0.2 0.2 0  
 234.4 232.6 230.6 228.7 227.1 226 224.9 223.5 222.3 221.6 221.4 221.7 222.7 224.1 226.1 228.8 232.2 236.6  
 241.5 247.2 253.6 259.2 263.4 267.7 271.4 272.7 271.7 268.2 261.7 251.8 245.8 238.9 231.3 223.4 214.8 206.2  
 197.9 189.9 182.4 175.8 167.6 154.8 136.4 115.4 92.4 62.9 34.3 16.9 11.1 8.7 7 5.2 3.6 2.3 1.3 0.7 0.5 0.4  
 0.3 0.2 0.2 0  
 234.4 233.4 232.1 230.6 229.6 229.2 228.7 228.1 227.5 227.5 228 229.1 230.6 233 236 239.5 244.2 249.6 255.8  
 263.4 271.9 279.9 286.7 293.6 300 304.9 308.3 310 309.1 304.3 300.7 295.5 290.2 283.4 276.3 267.8 258.7 249.8  
 241 232.3 224.5 212.8 196.3 173.1 152.2 122.7 79.2 41.7 17.6 10 7.8 6 4.1 2.6 1.5 0.9 0.5 0.4 0.3 0.2 0.2 0  
 234.4 234 233 232.3 232.1 232.1 232.2 232.3 232.5 233.1 234.3 236.1 238.6 241.7 245.3 250 255.6 262.4 270.2  
 279 289.3 299.2 308.4 317.5 326.2 333.9 340.9 346.8 350.7 350.9 349.5 347 343.9 339.3 333.6 326.5 318 308.9  
 299.5 291 282.7 271.3 254.7 232.4 208.9 177.6 129.1 72.5 28.9 11.8 7.9 5.9 4.2 2.7 1.6 0.9 0.6 0.4 0.2 0.2  
 0.2 0

