

PHILIPS

Recessed

EvoKit Click LED Retrofit Kit 2x2



Project: _____
 Location: _____
 Cat.No: _____
 Type: _____
 Lamps: _____ Qty: _____
 Notes: _____

Philips EvoKit click LED retrofit kit is an aesthetically pleasing and energy efficient LED retrofit kit designed to deliver a refreshed sleek and modern look with minimal material waste. Not only does it offer energy savings¹, it also helps reduce maintenance and installation costs due to its modular design, bulk packaging, and long LED lifetime. Additional information can be found at www.philips.com/evokit.

Products can be found on the DLC QPL by searching the 6 digit product number. Additional information can be found at www.philips.com/evokit.

EvoKit Click 2x2 with 0-10V Dimming ordering guide

Product Number	Description	Watts ³	Volts	Lumen Maint. (Hrs.) ²	Approx. Lumens ³	Color Temp. (K)	Efficacy	Dim	Pkg	DLC Code
CLK										
◆ 523589	EvoKit CLK 2x2 32L 29W 835 UNV 0-10 P4	29W	120-277	70,000	3200	3500	117	0-10	4 Pack	P5ZOVZ5C
523597	EvoKit CLK 2x2 32L 29W 840 UNV 0-10 P4	29W	120-277	70,000	3200	4000	119	0-10	4 Pack	P2B98AZY
521211	EvoKit CLK 2x2 32L 29W 835 UNV 0-10 P1	29W	120-277	70,000	3200	3500	117	0-10	Single Pack	PL1BNA6C
520221	EvoKit CLK 2x2 32L 29W 840 UNV 0-10 P1	29W	120-277	70,000	3200	4000	119	0-10	Single Pack	PAW881FC
CLKE (Energy Efficient)										
523621	EvoKit CLKE 2x2 32L 24W 835 UNV 0-10 P4	24W	120-277	70,000	3200	3500	141	0-10	4 Pack	PBBL99UF
◆ 523647	EvoKit CLKE 2x2 32L 24W 840 UNV 0-10 P4	24W	120-277	70,000	3200	4000	143	0-10	4 Pack	PCGIVN5U
521336	EvoKit CLKE 2x2 23L 16W 835 UNV 0-10 P1	16W	120-277	70,000	2300	3500	140	0-10	Single Pack	PMGH05VR
521344	EvoKit CLKE 2x2 23L 16W 840 UNV 0-10 P1	16W	120-277	70,000	2300	4000	142	0-10	Single Pack	P1ILMDP2
521377	EvoKit CLKE 2x2 32L 24W 835 UNV 0-10 P1	24W	120-277	70,000	3200	3500	141	0-10	Single Pack	P1IM1REQ
◆ 520247	EvoKit CLKE 2x2 32L 24W 840 UNV 0-10 P1	24W	120-277	70,000	3200	4000	143	0-10	Single Pack	PL4YK0DF
524363	EvoKit CLKE 2x2 23L 16W 850 UNV 0-10 P4	16W	120-277	70,000	2300	5000	142	0-10	4 Pack	PXHL577W
524371	EvoKit CLKE 2x2 32L 24W 850 UNV 0-10 P1	24W	120-277	70,000	3200	5000	143	0-10	Single Pack	PPIUJ9HB
525295	EvoKit CLKE 2x2 32L 24W 830 UNV 0-10 P1	24W	120-277	70,000	3200	3000	135	0-10	Single Pack	PLW3E21B

See footnotes on the last page.

◆ Made to stock product (Contact your Philips sales representative for stock availability and lead time).

Buy American Act Compliant** Evokit click 2x2 with 0-10V Dimming ordering guide

Product Number	Description	Watts ³	Volts	Lumen Maint. (Hrs.) ²	Approx. Lumens ³	Color Temp. (K)	Efficacy	Dim	Pkg	DLC Code
CLK										
*	EvoKit CLK 2x2 32L 29W 835 0-10 P4 BAC	29W	120-277	70,000	3200	3500	117	0-10	4 pack	*
	EvoKit CLK 2x2 32L 29W 840 0-10 P4 BAC	29W	120-277	70,000	3200	4000	119	0-10	4 pack	
	EvoKit CLK 2x2 32L 29W 835 0-10 P1 BAC	29W	120-277	70,000	3200	3500	117	0-10	Single pack	
	EvoKit CLK 2x2 32L 29W 840 0-10 P1 BAC	29W	120-277	70,000	3200	4000	119	0-10	Single pack	

Not all product variations listed on this page are DLC qualified. To ensure that a specific model is qualified, visit www.designlights.org/search



interact ready.

EvoKit Click LED retrofit kit 2x2

Product Number	Description	Watts ³	Volts	Lumen Maint. (Hrs.) ²	Approx. Lumens ³	Color Temp. (K)	Efficacy	Dim	Pkg	DLC Code
CLKE (Energy Efficient)										
*	EvoKit CLKE 2x2 32L 24W 835 0-10 P4 BAC	24W	120-277	70,000	3200	3500	141	0-10	4 pack	*
	EvoKit CLKE 2x2 32L 24W 840 0-10 P4 BAC	24W	120-277	70,000	3200	3500	143	0-10	4 pack	
	EvoKit CLKE 2x2 23L 16W 835 0-10 P1 BAC	16W	120-277	70,000	2300	3500	140	0-10	Single pack	
	EvoKit CLKE 2x2 23L 16W 840 0-10 P1 BAC	16W	120-277	70,000	2300	4000	142	0-10	Single pack	
	EvoKit CLKE 2x2 32L 24W 835 0-10 P1 BAC	24W	120-277	70,000	3200	3500	141	0-10	Single pack	
	EvoKit CLKE 2x2 32L 24W 840 0-10 P1 BAC	24W	120-277	70,000	3200	4000	143	0-10	Single pack	
	EvoKit CLKE 2x2 23L 16W 850 0-10 P4 BAC	16W	120-277	70,000	2300	5000	142	0-10	4 pack	
	EvoKit CLKE 2x2 32L 24W 850 0-10 P1 BAC	24W	120-277	70,000	3200	5000	143	0-10	Single pack	
	EvoKit CLKE 2x2 32L 24W 830 0-10 P1 BAC	24W	120-277	70,000	3200	3000	135	0-10	Single pack	

* for Product No. and Model No. please contact Philips Account Manager

** Failure to properly select the "BAC" suffix could result in you receiving product that is not BAA compliant product with no recourse for an RMA or refund. This BAC designation hereunder does not address (i) the applicability of, or availability of a waiver under, the Trade Agreements Act, or (ii) the "Buy America" domestic content requirements imposed on states, localities, and other non-federal entities as a condition of receiving.

EvoKit Click 2x2 with Interact Pro scalable SWZCS ordering guide

Product Number	Description	Watts ³	Volts	Lumen Maint. (Hrs.) ²	Approx. Lumens ³	Color Temp. (K)	Efficacy	Dim	Pkg	DLC Code
CLKE SWZCS (Energy Efficient Interact Pro scalable)										
◆ 114140	EvoKit CLKE 2x2 32L 24W 840 UNV SWZCS P4	24W	120-277V	70,000	3200	4000	138	SWZCS	4 Pack	PJHZ10F4
114157	EvoKit CLKE 2x2 32L 24W 835 UNV SWZCS P1	24W	120-277V	70,000	3200	3500	136	SWZCS	Single Pack	PYFQUQV4
◆ 121376	EvoKit CLKE 2x2 32L 24W 840 UNV SWZCS P1	24W	120-277V	70,000	3200	4000	138	SWZCS	Single Pack	P2WPWOM3
267674	EvoKit CLKE 2x2 32L 24W 835 UNV SWZCS P4	24W	120-277V	70,000	3200	3500	136	SWZCS	4 Pack	PG2IVTS2

See footnotes on the last page.

Buy American Act Compliant** EvoKit click 2x2 with Interact Pro scalable SWZCS ordering guide

Product Number	Description	Watts ³	Volts	Lumen Maint. (Hrs.) ²	Approx. Lumens ³	Color Temp. (K)	Efficacy	Dim	Pkg	DLC Code
CLKE SWZCS (Energy Efficient Interact Pro scalable)										
*	EvoKit CLKE 2x2 32L 24W 840 SWZCS P4 BAC	24W	120-277	70,000	3200	4000	137	SR	4 pack	*
	EvoKit CLKE 2x2 32L 24W 835 SWZCS P1 BAC	24W	120-277	70,000	3200	3500	132	SR	Single pack	
	EvoKit CLKE 2x2 32L 24W 840 SWZCS P1 BAC	24W	120-277	70,000	3200	4000	137	SR	Single pack	
	EvoKit CLKE 2x2 32L 24W 835 SWZCS P4 BAC	24W	120-277	70,000	3200	3500	136	SR	4 pack	

* for Product No. and Model No. please contact Philips Account Manager

** Failure to properly select the "BAC" suffix could result in you receiving product that is not BAA compliant product with no recourse for an RMA or refund. This BAC designation hereunder does not address (i) the applicability of, or availability of a waiver under, the Trade Agreements Act, or (ii) the "Buy America" domestic content requirements imposed on states, localities, and other non-federal entities as a condition of receiving.

Interact Pro scalable sensor for Foundation, Advanced & Enterprise tiers (SWZCS and an evolution of SpaceWise)

- SWZCS is a connected sensor with integral occupancy and daylight sensing and supports wireless mesh connectivity.
- The sensor works in the Foundation mode (similar to SpaceWise) when configured without a gateway or in an Interact Pro Advanced or Enterprise mode if a compatible gateway is used.
- Interact Pro includes an App, a portal and a broad portfolio of wireless luminaires, lamps and retrofit kits all working on the same system.
- Startup is implemented via Interact Pro App (Android or iPhone) & Bluetooth connectivity. The App provides flexibility to choose between a gateway or non gateway mode for setup.
- Setup with the gateway requires wired internet access to the gateway. It is possible to add a gateway at a later point.
- Prepare project configuration steps remotely and use IRT9015 remote onsite to identify and group devices together.
- Compatible with:
 - UID8451/10 wireless dimmer switch
 - SWS200 wireless scene switch
 - IRT9015 – handheld remote for grouping and configuration (at least one remote required for any SWZCS installation)
- For more information on Interact Pro visit: www.interact-lighting.com/interact-proscalablesystem
- For more information on Interact Ready visit: www.philips.com/interact-ready

EvoKit Click LED retrofit kit 2x2

Interact Pro scalable system			
	Foundation	Advanced	Enterprise
Dimming, grouping, and zoning	✓	✓	✓
Bluetooth and ZigBee enabled	✓	✓	✓
Motion sensing and daylight harvesting	✓	✓	✓
Integration with 0-10V and phase dimming fixtures	✓	✓	✓
Code compliance	✓	✓	✓
Granular dimming and dwell time	✓	✓	✓
Energy reporting and monitoring		✓	✓
Scheduling		✓	✓
Demand response		✓	✓
BMS integration (BACnet)			✓
Floor plan visualization			✓
IoT sensors for wellness			✓
IoT Apps for productivity			✓

Currently supported maximum system size

To be able to design the lighting system correctly for the customer, it is important to know the prime characteristics of the system, its possibilities and limitations.

System level	
Total number of gateways	Unlimited
Total number of devices	200 per network
• luminaires with integrated sensors	150
• smart TLEDs	150
Total number of ZGP devices (sensors and switches)	50
• sensors	30
• switches	50
• zones and groups	64
Group level	
Recommended number of lights	40 (recommended 25)
Number of ZGP devices	5
Number of scenes	16

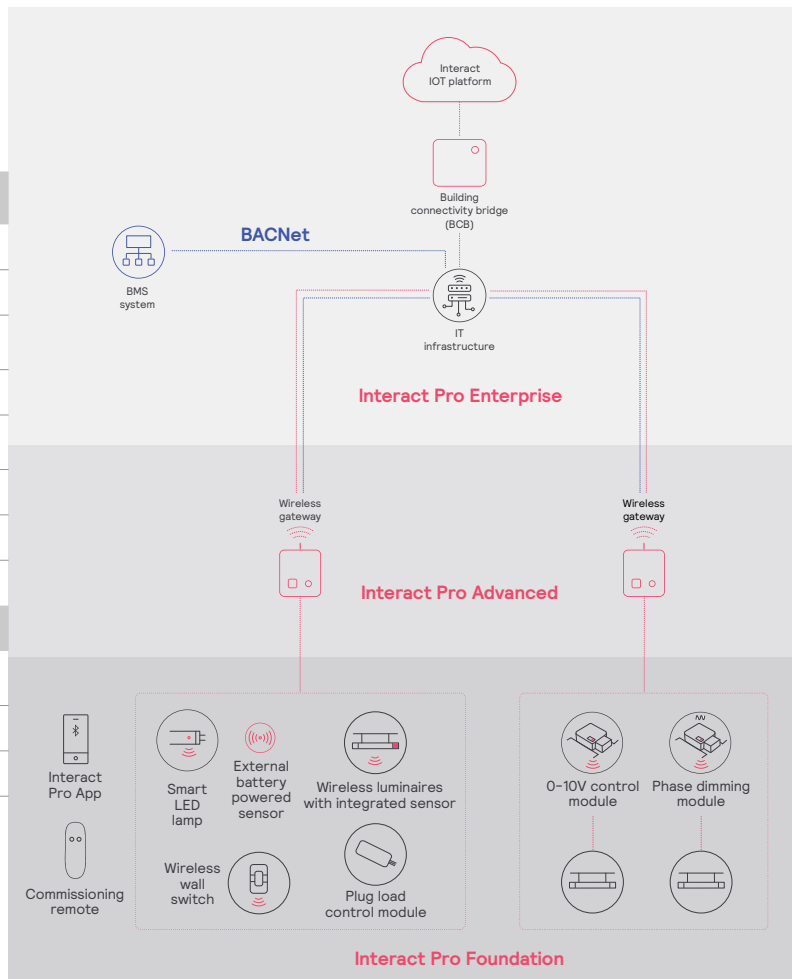

EvoKit Click LED retrofit kit 2x2

EvoKit Click 2x2 with Spacewise SWZDT ordering guide

Product Number	Description	Watts ³	Volts	Lumen Maint. (Hrs.) ²	Approx. Lumens ³	Color Temp. (K)	Efficacy	Dim	Pkg	DLC Code
CLKE SWZDT (Energy Efficient SpaceWise DT)										
◆ 523878	EvoKit CLKE 2x2 32L 24W 840 UNV SWZ P4	24W	120-277	70,000	3200	4000	138	SWZDT	4 Pack	PAV1FT8Y
◆ 523464	EvoKit CLKE 2x2 32L 24W 835 UNV SWZ P1	24W	120-277	70,000	3200	3500	136	SWZDT	Single Pack	PIT3B0KJ
◆ 523472	EvoKit CLKE 2x2 32L 24W 840 UNV SWZ P1	24W	120-277	70,000	3200	4000	138	SWZDT	Single Pack	PJOW6RSK

See footnotes on the last page.

◆ Made to stock product (Contact your Philips sales representative for stock availability and lead time).

Buy American Act Compliant** Evokit click 2x2 with Spacewise SWZDT ordering guide

Product Number	Description	Watts ³	Volts	Lumen Maint. (Hrs.) ²	Approx. Lumens ³	Color Temp. (K)	Efficacy	Dim	Pkg	DLC Code
CLKE SWZDT (Energy Efficient Spacewise DT)										
*	EvoKit CLKE 2x2 32L 24W 840 SWZ P4 BAC	24W	120-277	70,000	3200	4000	138	SWZDT	4 pack	*
	EvoKit CLKE 2x2 32L 24W 835 SWZ P1 BAC	24W	120-277	70,000	3200	3500	136	SWZDT	Single pack	
	EvoKit CLKE 2x2 32L 24W 840 SWZ P1 BAC	24W	120-277	70,000	3200	4000	138	SWZDT	Single pack	

* for Product No. and Model No. please contact Philips Account Manager

** Failure to properly select the "BAC" suffix could result in you receiving product that is not BAA compliant product with no recourse for an RMA or refund. This BAC designation hereunder does not address (i) the applicability of, or availability of a waiver under, the Trade Agreements Act, or (ii) the "Buy America" domestic content requirements imposed on states, localities, and other non-federal entities as a condition of receiving.

SpaceWise SWZDT

- Standalone daylight and occupancy sensing with advanced grouping, wireless mesh networking and dwell time.
- Commissioning via compatible Android phone and Philips Field App
- Dimming via compatible Zigbee wireless wall switch only (see link below for details)
- Register for the commissioning app at <http://registration.componentcloud.philips.com/appregistration/>
- Integral sensing options may not be combined
- For more information including recommended switches, refer to the following: –
SWZDT – www.usa.lighting.philips.com/systems/lighting-systems/spacewise

EvoKit Click LED retrofit kit 2x2

EvoKit Click 2x2 Sensor Ready ordering guide

Product Number	Description	Watts ³	Volts	Lumen Maint. (Hrs.) ²	Approx. Lumens ³	Color Temp. (K)	Efficacy	Dim	Pkg	DLC Code
CLKE SR (Energy Efficient Sensor Ready)										
523639	EvoKit CLKE 2x2 32L 25W 835 UNV SR P4	25W	120-277	70,000	3200	3500	136	SR	4 Pack	PUB299A2
523654	EvoKit CLKE 2x2 32L 25W 840 UNV SR P4	25W	120-277	70,000	3200	4000	138	SR	4 Pack	PEKKEW6M
521385	EvoKit CLKE 2x2 32L 25W 835 UNV SR P1	25W	120-277	70,000	3200	3500	136	SR	Single Pack	PZUA74W7
520254	EvoKit CLKE 2x2 32L 25W 840 UNV SR P1	25W	120-277	70,000	3200	4000	138	SR	Single Pack	PYOVOK5S

See footnotes on the last page.

Buy American Act Compliant** Evokit click 2x2 Sensor Ready ordering guide

Product Number	Description	Watts ³	Volts	Lumen Maint. (Hrs.) ²	Approx. Lumens ³	Color Temp. (K)	Efficacy	Dim	Pkg	DLC Code
CLKE SR (Energy Efficient Sensor Ready)										
*	EvoKit CLKE 2x2 32L 25W 835 SR P4 BAC	25W	120-277	70,000	3200	3500	136	SR	4 pack	*
	EvoKit CLKE 2x2 32L 25W 840 SR P4 BAC	25W	120-277	70,000	3200	4000	138	SR	4 pack	
	EvoKit CLKE 2x2 32L 25W 835 SR P1 BAC	25W	120-277	70,000	3200	3500	136	SR	Single pack	
	EvoKit CLKE 2x2 32L 25W 840 SR P1 BAC	25W	120-277	70,000	3200	4000	138	SR	Single pack	

* for Product No. and Model No. please contact Philips Account Manager

** Failure to properly select the "BAC" suffix could result in you receiving product that is not BAA compliant product with no recourse for an RMA or refund. This BAC designation hereunder does not address (i) the applicability of, or availability of a waiver under, the Trade Agreements Act, or (ii) the "Buy America" domestic content requirements imposed on states, localities, and other non-federal entities as a condition of receiving.

EvoKit Sensor Ready (SR) with Philips Advance Xitanium SR for connected lighting solutions

EvoKit SR is a new platform that allows users to choose different control platforms to suit their needs and budget; from simple occupancy and daylight sensing to cloud-connected data-reporting sensing. This empowers users to fine-tune their energy use for reduced energy costs. Various Interact, Philips SpaceWise, and EasySense controls are available. Please refer to Philips.com/Evokit for details. Contact your Philips representative for a current list of additional approved sensors. Sensors are connected in the field with just a few simple steps:

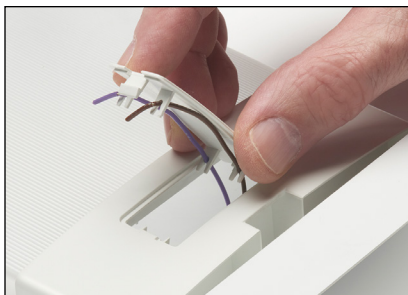

Step 1: EvoKit click SR is shipped with a plate covering the sensor hole. There are two wires secured to the back of the plate. The plate can be removed before or after you install the EvoKit click SR in the ceiling.

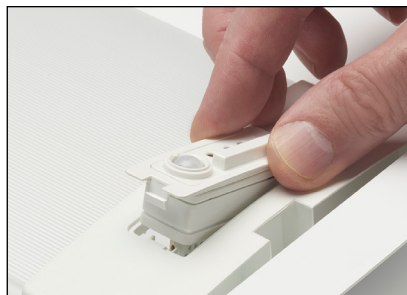

Step 2: Remove the two wires that were secured to the back of the plate and insert them in an approved sensor for use with EvoKit. They are not polarity sensitive.



Step 3: An adapter bracket is shipped with every EvoKit click SR. Install this adapter ring to the sensor and make sure it is securely fit. Then place the sensor and adapter bracket into the EvoKit SR endcap.

EvoKit bulk pack

EvoKit click is designed to reduce the hidden environmental costs of lighting retrofits. With newly designed multi-unit packaging for EvoKit click, cardboard waste from the 2x4 and 2x2 troffer kits has been reduced by 66% and 77% respectively compared to its predecessor, EvoKit Gen4.

Previously, only 24 kits were able to fit on a single pallet, but, with the new multi-unit packaging, 60 2x4 kits fit on one pallet. This allows for 3,840 units to be fully loaded onto a 53' truck compared to 1,536 units of the previous generation. This results in 2.5x better transportation utilization and storage capacity with the EvoKit click.



Commercial Product Name	Order Code
EasySense EVO200	516575
Philips single rocker self powered wireless switch	UID8451/10

* EVO200 comes pre-installed in the Gen4 bracket. To install in EvoKit click, this bracket will need removed in the field. Please see www.philips.com/evokit for instructions on removing bracket.

EvoKit Click LED retrofit kit 2x2

Application

- A highly efficient, visually comfortable, architecturally styled LED retrofit kit designed to replace recessed linear fluorescent troffers.
- Unique modular design offers refreshing new look in the ceiling when compared to traditional fluorescent luminaires.
- Single light bar combined with slanted troffer helps reflect light to reduce glare and provide uniform light distribution making it ideal for applications such as offices, schools, healthcare and retail.
- Excellent color rendering with a CRI above 80.
- Extremely high efficacies up to 149 lumens per watt.
- LEDs are an excellent source for use with controls since dimming or frequent switching does not degrade the performance or life of the source.
- Designed for use with standard grid (NEMA "G") or Narrow Grid (NEMA "NFG") ceiling T-Grids.
- High efficiency source and luminaire design help significantly reduce energy consumption and more easily comply with known energy codes.
- Helps meet regulation requirements such as ASHRAE 90.1 and Title 24 when matched with suitable controls.
- EvoKit click is designed for use in most recessed troffers. Some existing fixtures may have features which interfere. Please refer to schematics below.

Enclosure Construction/Finish

- Simple design allows for quick installation in existing luminaire without the need to break the ceiling plenum.
- Constructed using galvanized steel which helps fight rust and makes for more durable product.
- Integrated securement tabs for securement to existing troffer housing.
- Minimum depth of only 3" necessary to allow proper clearance and installation of the EvoKit.
- Retrofit kit is powder coated after fabrication with high quality, durable finish to ensure no unfinished edges and avoid future potential of corrosion.
- Components fit together easily without the need for tools during installation. In addition the light module can be removed from below the ceiling for convenient maintenance and upgrades

Electrical

- Multiple driver options available
 - Philips Advance CertaDrive drivers with 0-10V dimming allow for maximum fixture efficiency and provide 10% dimming.
 - Philips Advance Xitanium SR drivers allow for connectivity options to multiple platforms.
- 5-year limited warranty includes all components of the retrofit kit, including driver, LED board and nonelectrical components."
- Listed with UL and Design Lights Consortium[®] to ensure quality performance and safety standards are met.
- High efficiency LEDs have a minimum 70,000 hour rated life (L₇₀).

Accessories

- Suitable for use with Philips 503441 emergency backup or with Philips ER100 UL924 emergency relay.
- Earthquake cables available for additional securement to the existing troffer for areas where required.
- EvoKit accessory replacement kit comes with quarter turns (51 pieces), quick disconnects (12 pieces), spare sensor brackets (12 pieces) and troffer retrofit labels (12 pieces).

Prod. No.	Description
502435	Earthquake cable 317mm
503441	EvoKit field installed emergency battery backup
522094	EvoKit accessory replacement kit
563569	EvoKit field installed ER100 UL924 emergency relay (requires the use of the ER100 field installation kit of wires and screws)
266833	EvoKit ER100 field install kit (comes in pack of 20). One pack needed per emergency relay

Dimensions 2x2

EvoKit click was designed to fit into most parabolic and lensed-recessed troffers with minimum dimensional requirements shown below. Philips recommends a sample installation prior to ordering project quantities to ensure compatibility. Philips EvoKit click retrofit kits are not compatible with air handling fixtures.

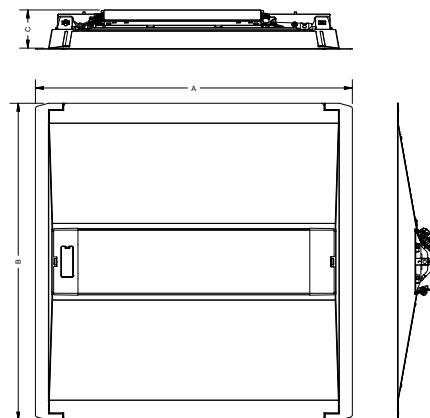

A Face Plate Length	B Face Plate Width	C Height
47.83"	23.9"	2.99"

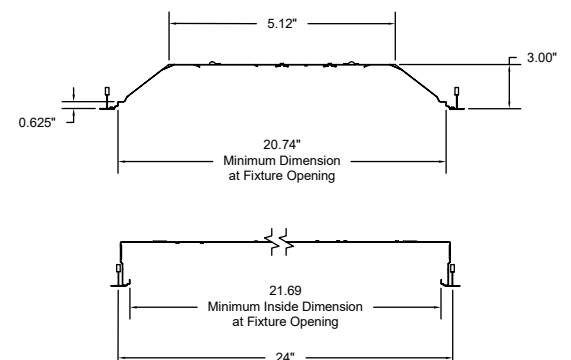

EvoKit Click LED retrofit kit 2x2

EvoKit CLK 2x2 32L 29W 835 UNV 0-10 P1, 3,206 delivered lumens

Catalog No.	521211	Candlepower				
Test No.	21211	Angle	End	45	Cross	Back-45
S/MH	1.4	0	1233	1233	1233	1233
Lamp Type	LED	5	1223	1227	1233	1227
Lumens/Watt	117	15	1181	1186	1193	1184
Input Watts	29	25	1083	1079	1088	1077
		35	923	918	930	915
		45	712	728	741	725
		55	499	539	545	535
		65	312	360	362	355
		75	155	212	224	208
		85	37	75	75	71

The photometric results were obtained in the Design Lights Consortium Test Lab which is NVLAP accredited by the National Institute of Standards and Technology

Photometric values based on tests performed in compliance with LM-79

Coefficients of Utilization									
EFFECTIVE FLOOR CAVITY REFLECTANCE 20 PER (pfc=0.20)									
pcc	80			70			50		
pw	70	50	30	70	50	30	50	30	
RCR									
0	119	119	119	116	116	116	111	111	
1	109	104	100	106	102	98	98	95	
2	99	91	85	97	89	83	86	81	
3	91	80	72	88	79	71	76	70	
4	83	72	63	81	70	62	68	61	
5	77	64	55	75	63	55	61	54	
6	71	58	49	69	57	49	55	48	
7	66	53	44	64	52	44	50	43	
8	62	48	40	60	48	40	46	39	
9	58	44	36	56	44	36	43	35	
10	54	41	33	53	40	33	39	33	

Light Distribution			Average Luminance			
Degrees	Lumens	% Luminaire	Angle	End	45°	Cross
0-30	947	29.9	45	3418	3498	3559
0-40	1520	48.0	55	2954	3191	3225
0-60	2550	80.5	65	2505	2891	2912
0-90	3169	100	75	2036	2780	2944
			85	1434	2926	2938

EvoKit CLKE 2x2 23L 16W 835 UNV 0-10 P1, 2,313 delivered lumens

Catalog No.	521336	Candlepower				
Test No.	21336	Angle	End	45	Cross	Back-45
S/MH	1.4	0	931	931	931	931
Lamp Type	LED	5	925	923	931	927
Lumens/Watt	140	15	885	885	891	885
Input Watts	16	25	804	799	797	801
		35	684	662	655	667
		45	536	514	511	518
		55	370	366	365	371
		65	219	238	232	242
		75	103	134	135	137
		85	21	43	41	47

The photometric results were obtained in the Design Lights Consortium Test Lab which is NVLAP accredited by the National Institute of Standards and Technology

Photometric values based on tests performed in compliance with LM-79

Coefficients of Utilization									
EFFECTIVE FLOOR CAVITY REFLECTANCE 20 PER (pfc=0.20)									
pcc	80			70			50		
pw	70	50	30	70	50	30	50	30	
RCR									
0	119	119	119	116	116	116	111	111	
1	109	105	101	107	102	99	98	95	
2	100	92	85	97	90	84	87	81	
3	91	81	73	89	80	72	77	71	
4	84	72	64	82	71	63	69	62	
5	78	65	56	75	64	56	62	55	
6	72	59	50	70	58	50	56	49	
7	67	54	45	65	53	45	51	44	
8	62	49	41	61	48	40	47	40	
9	58	45	37	57	45	37	43	36	
10	55	42	34	53	41	34	40	33	

Light Distribution			Average Luminance			
Degrees	Lumens	% Luminaire	Angle	End	45°	Cross
0-30	705	31.3	45	2040	1953	1944
0-40	1121	49.7	55	1732	1718	1709
0-60	1849	82	65	1391	1516	1475
0-90	2255	100	75	1065	1391	1406
			85	650	1328	1250

EvoKit CLKE 2x2 32L 25W 835 UNV SR P1, 3,255 delivered lumens

Catalog No.	521385	Candlepower				
Test No.	21385	Angle	End	45	Cross	Back-45
S/MH	1.4	0	1296	1296	1296	1296
Lamp Type	LED	5	1291	1287	1294	1287
Lumens/Watt	136	15	1234	1231	1240	1231
Input Watts	26	25	957	924	914	924
		35	957	924	914	924
		45	750	715	714	716
		55	520	513	509	513
		65	311	335	326	335
		75	148	189	191	190
		85	32	62	59	65

The photometric results were obtained in the Design Lights Consortium Test Lab which is NVLAP accredited by the National Institute of Standards and Technology

Photometric values based on tests performed in compliance with LM-79

Coefficients of Utilization									
EFFECTIVE FLOOR CAVITY REFLECTANCE 20 PER (pfc=0.20)									
pcc	80			70			50		
pw	70	50	30	70	50	30	50	30	
RCR									
0	119	119	119	116	116	116	111	111	
1	109	105	101	107	102	99	98	95	
2	100	92	85	97	90	84	86	81	
3	91	81	73	89	80	72	77	71	
4	84	72	64	82	71	63	69	62	
5	78	65	56	75	64	56	62	55	
6	72	59	50	70	58	50	56	49	
7	67	54	45	65	53	45	51	44	
8	62	49	41	61	48	40	47	40	
9	58	45	37	57	45	37	43	36	
10	55	42	34	53	41	34	40	33	

Light Distribution			Average Luminance			
Degrees	Lumens	% Luminaire	Angle	End	45°	Cross
0-30	979	31.2	45	2850	2720	2714
0-40	1558	49.6	55	2439	2407	2387
0-60	2569	81.9	65	1981	2133	2073
0-90	3138	100	75	1541	1967	1979
			85	993	1903	1815

EvoKit Click LED retrofit kit 2x2

Energy saving solution – EvoKit CLKE 2'x2'

Estimated lighting costs using a standard 2 lamp U bend 2x2 troffer

Present wattage	59	W
× Annual operating hours	4,380	hrs
	=	258,420 Watt-Hours
÷ 1,000	=	258.40 kWh per year
× kWh rate of \$0.10	=	\$25.84 per year
× 125 fixtures	\$3,230.25	annual energy cost per space

Estimated lighting costs using a using a Philips 32L 2x2 EvoKit CLKE

Present wattage	24	W
× Annual operating hours	4,380	hrs
	=	105,120 Watt-Hours
÷ 1,000	=	105.12 kWh per year
× kWh rate of \$0.10	=	\$10.51 per year
× 125 fixtures	\$1,314.00	annual energy cost per space

Total estimated annual savings[‡] \$1,916.25

[‡] Based on 125 fixtures per space operating 4,380 hours a year. 125 fixtures is roughly equivalent to a 10,000 square foot space. kWh rates will vary.

FOOTNOTES:

- 1) Please refer to the energy saving chart above for details.
 - 2) L₇₀ 72,000 hours @ 35°C based on TM21 and LM80.
 - 3) Based on photometric testing consistent with IES LM-79. Actual wattage may differ by +/- 10%. Actual initial lumen output may vary between -10 and +10% of the rated lumens.
- *** Please visit <http://www.usa.lighting.philips.com/support/support/warranty> for full details.
- † Restrictions on Hazardous Substances (RoHS) is a European directive (2002/95/EC) designed to limit the content of 6 substances [lead, mercury, cadmium, hexavalent chromium, polybrominated biphenyls (PBB), and polybrominated diphenyl ethers (PBDE)] in electrical and electrical products. For products used in North America, compliance with RoHS is voluntary and self-certified.
- ‡ Evokit luminaires are Design Lights Consortium qualified. Please see the DLC QPL list for exact catalog numbers (<http://www.designlights.org/QPL>).

