

BrightSites

by  Signify

BrightSites C7012 luminaire with Gbit technology

Time to unlock the wireless connectivity potential of the lighting grid.

Benefits:

- The wireless backhaul you need for fixed wireless access, 4G/5G densification, cameras and IoT broadband applications
- Avoids trenching and permits for high-capacity connectivity
- Self-optimizing, mesh network for high availability
- Good application coverage thanks to wide range of optics and tunable flux



BrightSites C7012 luminaire with Gbit technology

BrightSites C7012 luminaire with Gbit technology is a new point to multipoint 60GHz product that turns lighting grids into high-bandwidth communication infrastructures. It offers the advantages of a high-quality lighting system and mmWave spectrum - multi-gigabit capacity, immunity to interference and massive amounts of available spectrum. All in an easy-to-deploy solution for scalable, stress-free coverage extension and multi-path reliability across neighborhoods and business parks.

Lighting Specifications

Lumen output	6000lm – 20000lm
Color temperature	3000 K or 4000K, other CCT options on request
Optics	IES Type 2, 3, 4, 5
CRI	>70 or >80

RF Specifications

Topologies	PtP, PtMP, Mesh
Sectors	4x90° sector for 360° coverage Horizontal scanning: 90° Vertical scanning: 12°
Frequency & Duplexing	57-66 GHz, TDD/TDMA
Channels & Width	4x non-overlapping channels, 2,160 MHz wide
Network Synchronization	Onboard
Radio OTA Rate	Up to 3,800 Mbps per sector
Aggregate Throughput	Up to 3,800 Mbps per sector Up to 15 Gbps per node
Maximum Range	1,000ft / 300m
Ethernet Features	IEEE 802.1d transparent bridging. Provider bridge - VLAN & VLAN stacking.

Electrical Specifications

Input voltage	220/240VAC, 50-60 Hz (EU) 120-277VAC, 50-60Hz (NAM)
Power consumption	Lighting: 60W to 145W RF: 48W no PoE Out, 90W with 42W PoE Out
Protection class	Surge protection: 10kV
Dimming	Yes, via Interact City

Other Specifications

Operating Temperature	Lights ON -40° to 95°F (-40° to +35°C) Lights OFF -40° to 95°F (-40° to +40°C)
Weight	18kg
Dimension (diameter x height)	See next page
Material	Housing: Die cast aluminium Top Canopy: Injection Moulded Plastic
Impact Rating	IK08
Ingress Protection	Outdoor (IP65), rated for wet locations
Mounting Types	Standard Arm (AR) Wall (WS) Retrofit Arm (RAM) Slip fitter (SF)
PoE Out	M-12 socket for PoE Out up to 35W (IEEE 802.3bt)
Security	AES 128-bits OTA, GUI over HTTPS, CLI over SSH.

Drawings

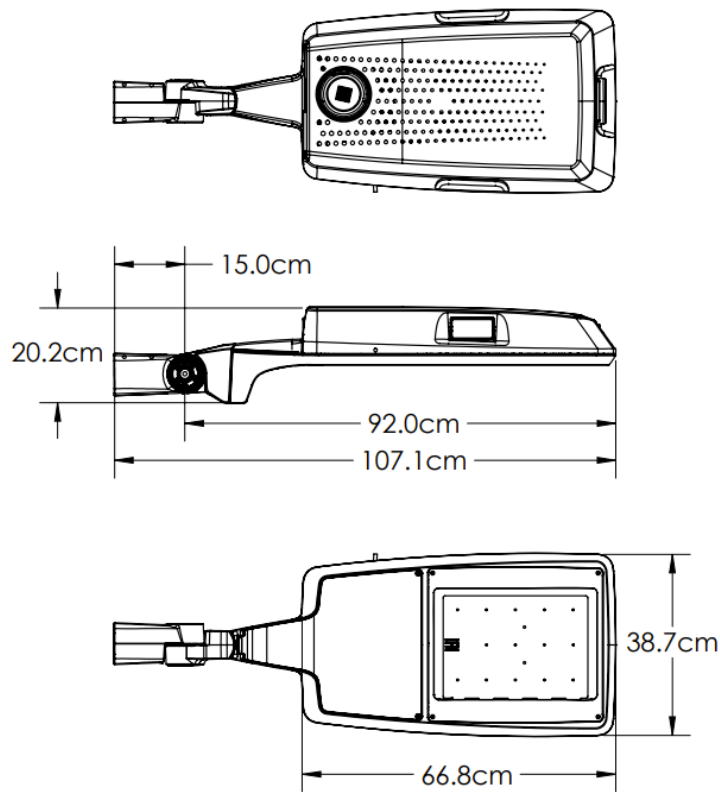

Network Architecture C

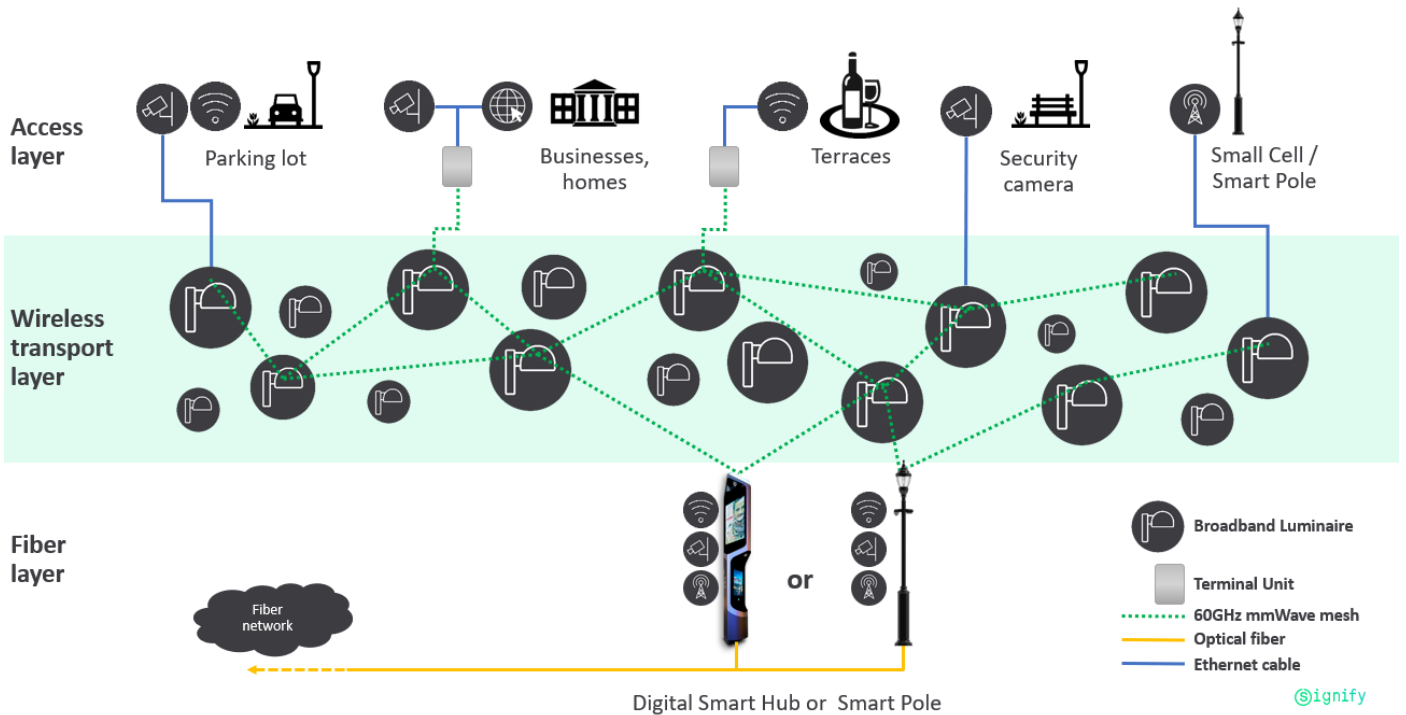

Additional Images

