

Signify

Sunstay Pro gen2

VGP726 Off Grid

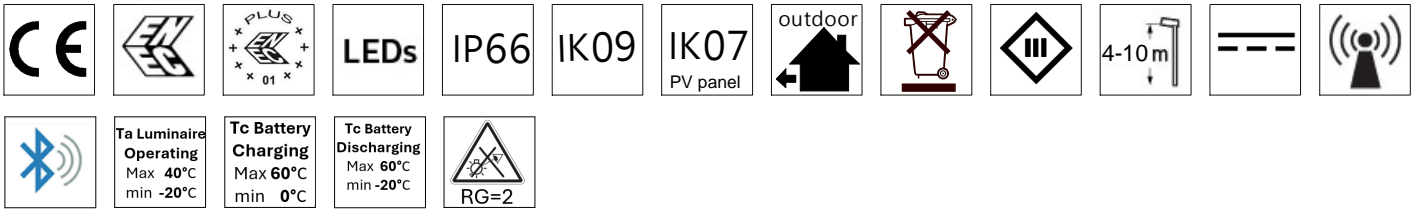

The luminaire should be positioned so that prolonged staring into the luminaire at a distance closer than 0,384 m is not expected

Connect the battery for luminaire operation

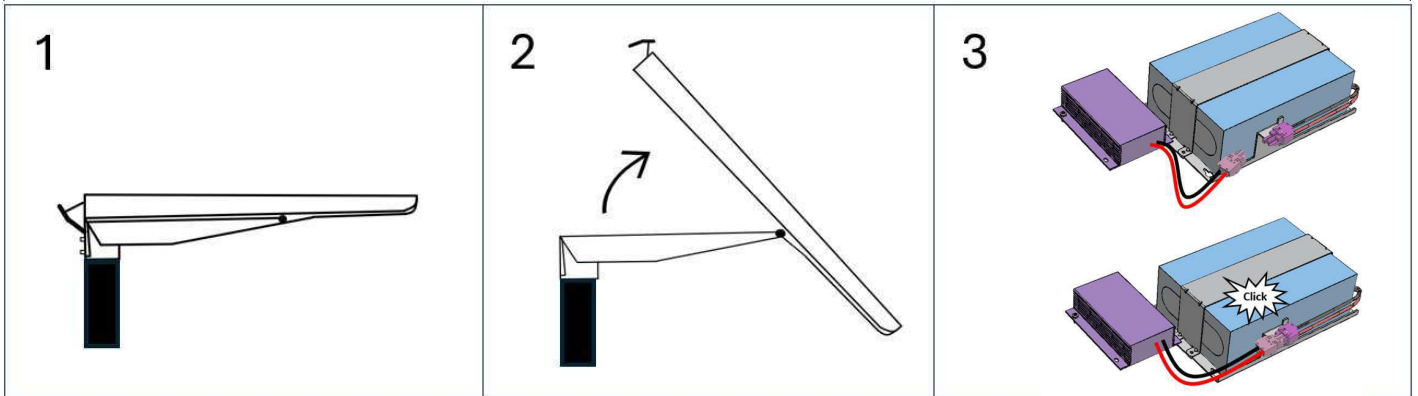

- This luminaire must be installed by qualified personnel only
- Disconnect battery and panel before servicing
- Use gloves to install/service the luminaire
- Always follow this mounting instructions to fix the luminaire
- Never modify the luminaire nor the fixation locations for installation
- Risk of accident due to incorrect tightening torque



583 - 443000022506

2025-08-26
© Signify Holding
All rights reserved

i Dimensions

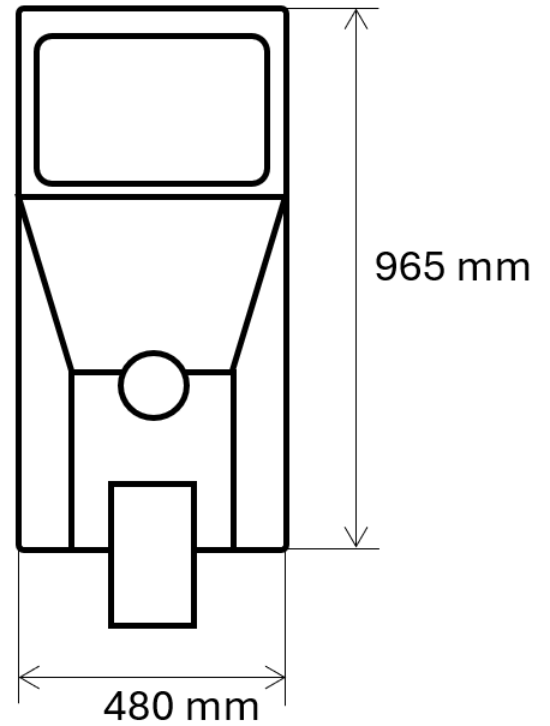
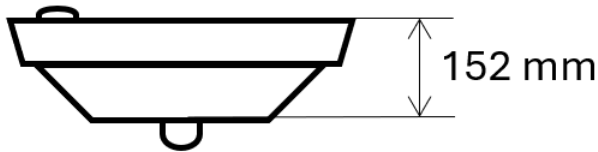
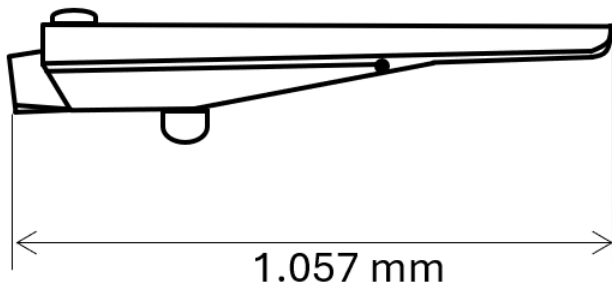

Weigth	
SunStay PRO Gen2 OG 12Ah	24,2 kg
SunStay PRO Gen2 OG 18Ah	25,5 kg
SunStay PRO Gen2 OG 30Ah	28,0 kg



i S.Cx values

	From 0 to 15°	20°
S (m ²)	0,11	0,21
S.Cx (m ²)	0,15	0,19

i Energy efficiency class

LED CRI	70	70	80
LED CCT	4000K	3000K	3000K
Energy Eff. Class	D	D	E

Inrush Current 65A
Inrush Current Time width 0.8ms

⚠ For optimal performance of the luminaire contact your local SIGNIFY employee for solar sizing and configuration.

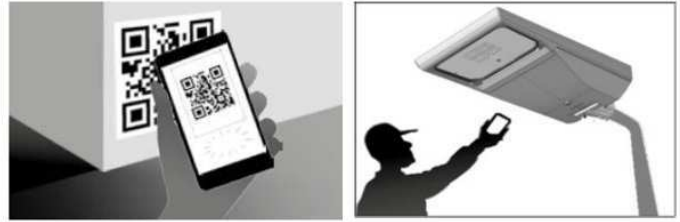
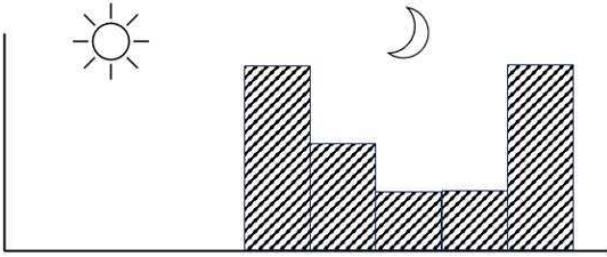

⚠ The installation of the luminaire is not recommended under these conditions:

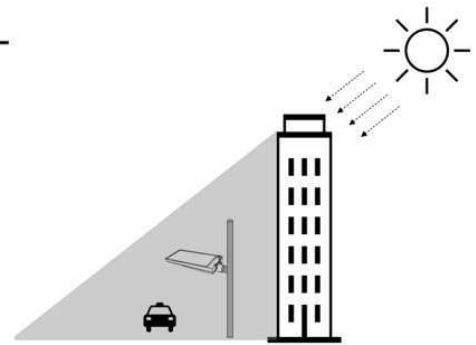
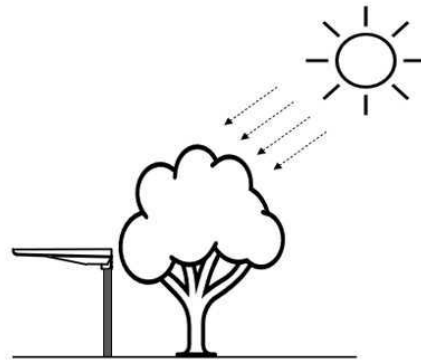
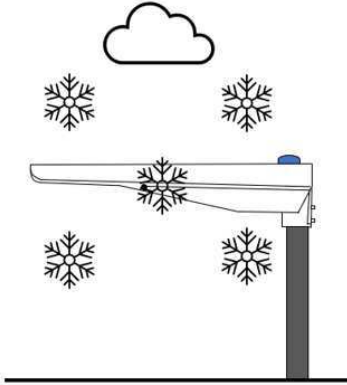

⚠ The luminaire performance and battery charging can be affected by external parameters.

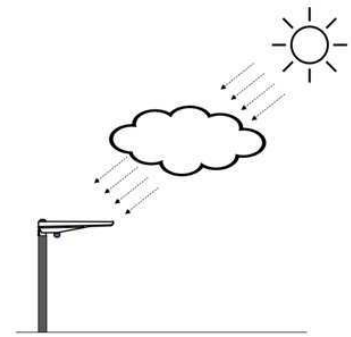
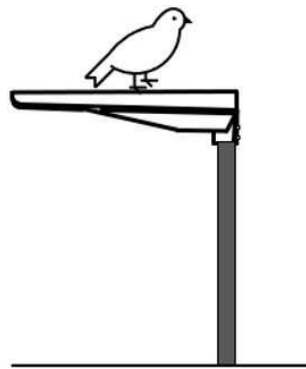
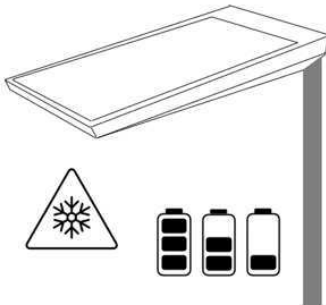

i Additional photovoltaic vertical panels can be fixed to the pole. Contact your local SIGNIFY employee for further information.

911401822202	200Wp Vertical Panel Subsystem Vmpp 36V
912300058711	Kit for installation of the PV Vertical Panel

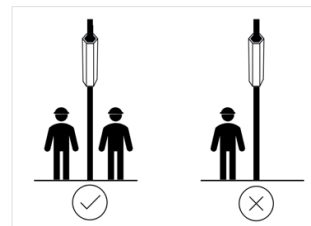
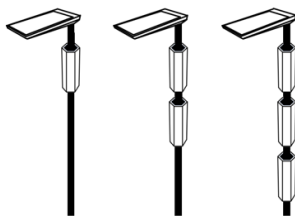

Please, refer to the specific *Vertical Panel Mounting Instructions* when ordering this option.

i Spigot fixation

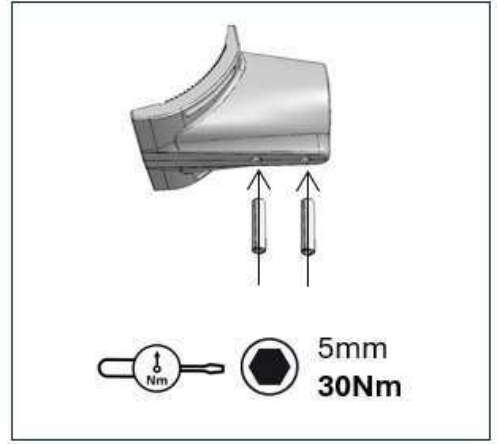
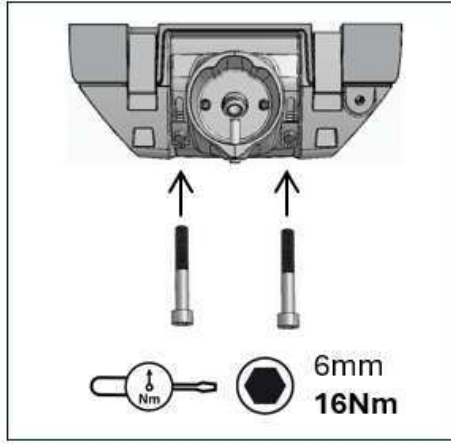
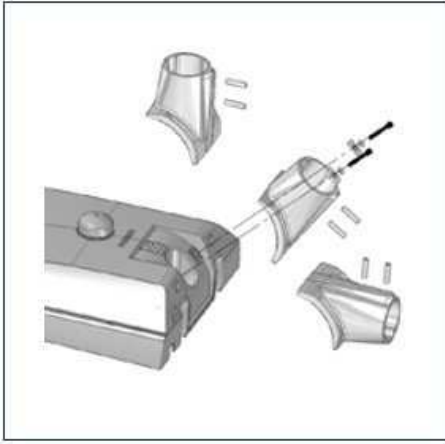

i Luminaire orientation

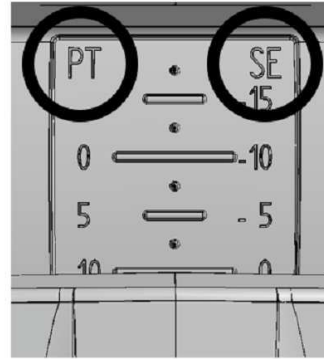
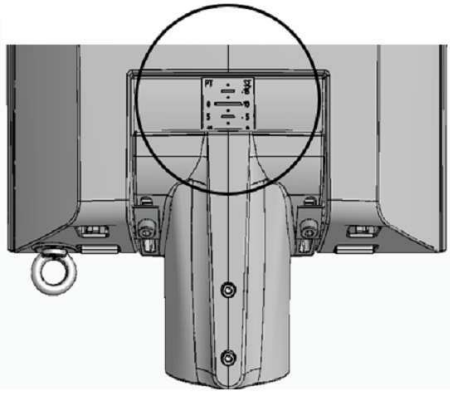

Post Top (PT):
Ø76mm or Ø60mm

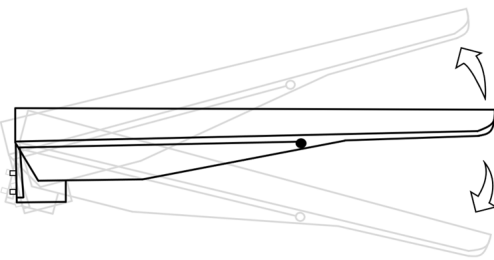

20°
17,5°
15°
12,5°
10°
7,5°
5°
2,5°
0°



Side Entry (SE):
Only Ø60mm

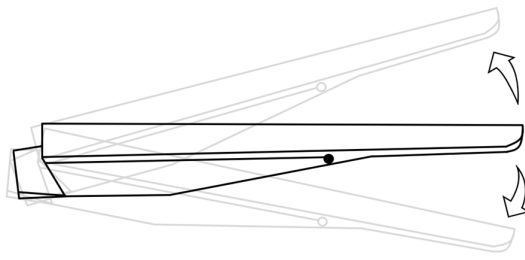

10°
7,5°
5°
2,5°
0°
-2,5°
-5°
-7,5°
-10°
-12,5°
-15°
-17,5°
-20°



Spigot into pole

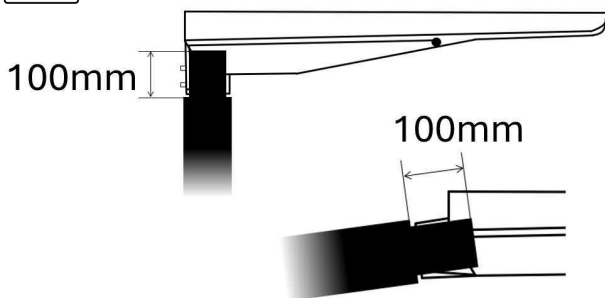

Open luminaire only if base is supported or if luminaire is installed on the pole

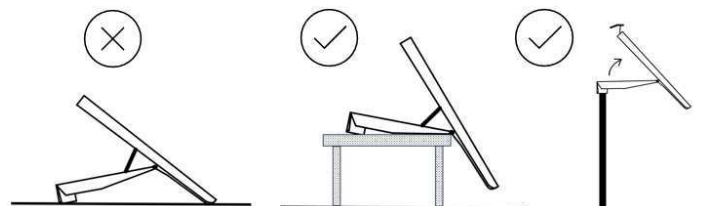

Sensors and type of luminaire

Luminaire	Version
No sensors	A
Bottom Sensor (OMS)	B
Top Sensor (OLC)	C
Top & Bottom Sensor (OLC & OMS)	D

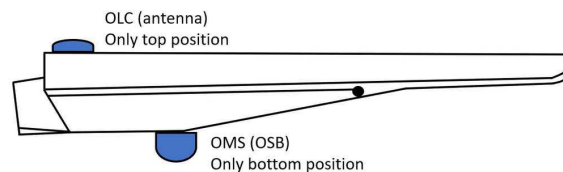

Sensors and type of luminaire

Description	Spare Part Code
AGP725 LLC7852/00 CT NODE ZHAGA DC EU4VF LG (Light Grey)	912300060696
AGP725 LLC7853/00 CT NODE ZHAGA DC EU4VF DG (Dark Grey)	912300060395

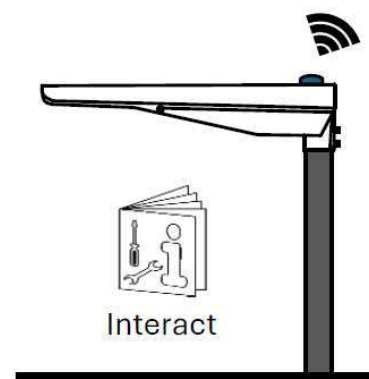
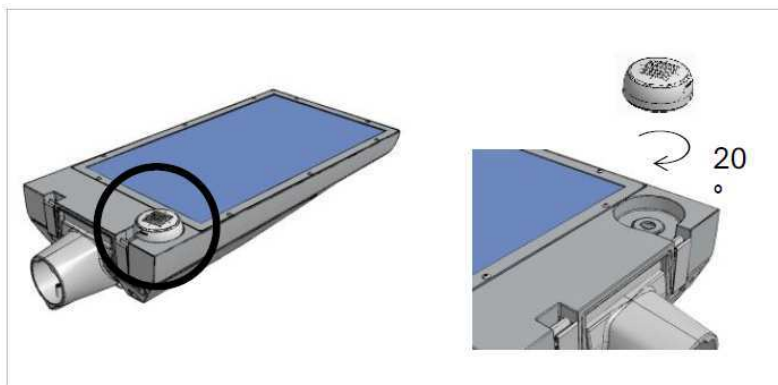

Sensors and type of luminaire

Description	Spare Part Code
AGP725 LRI8135/00 OUTDOOR SENSOR BUNDLE	912300060396

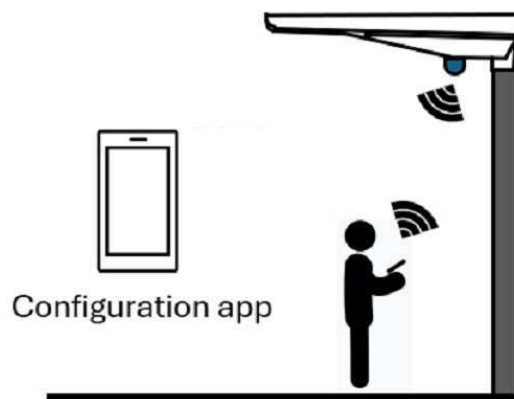

i The luminaire type A or B can be upgraded to C or D

Disconnect Battery and PV panel first before disconnecting or upgrading the product from A or B to C or D

Luminaire A or B: Charge Controller CC G5 is connected to BLE Bluetooth module

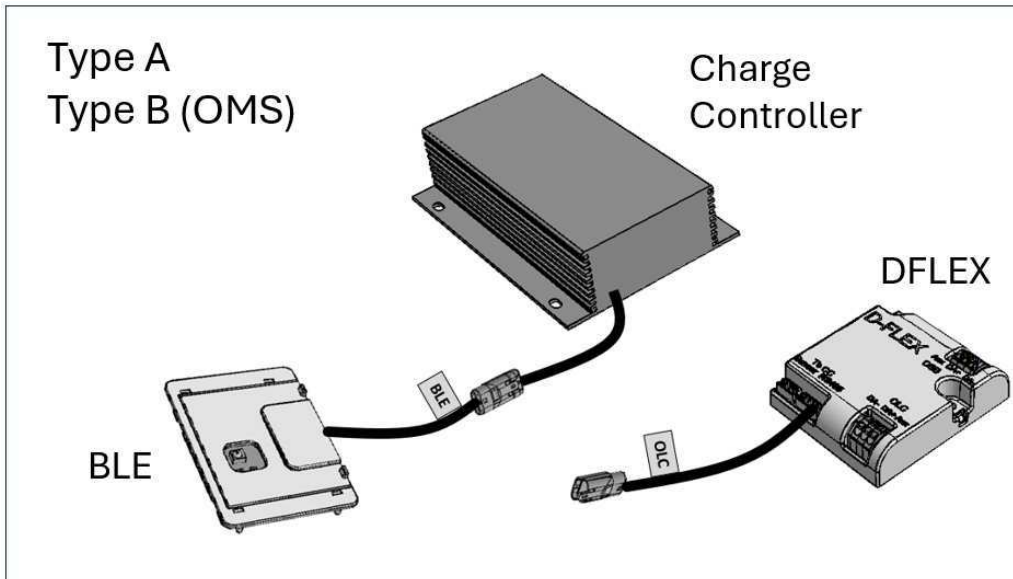

Luminaire C or D: Charge Controller CC G5 is connected to DFLEX

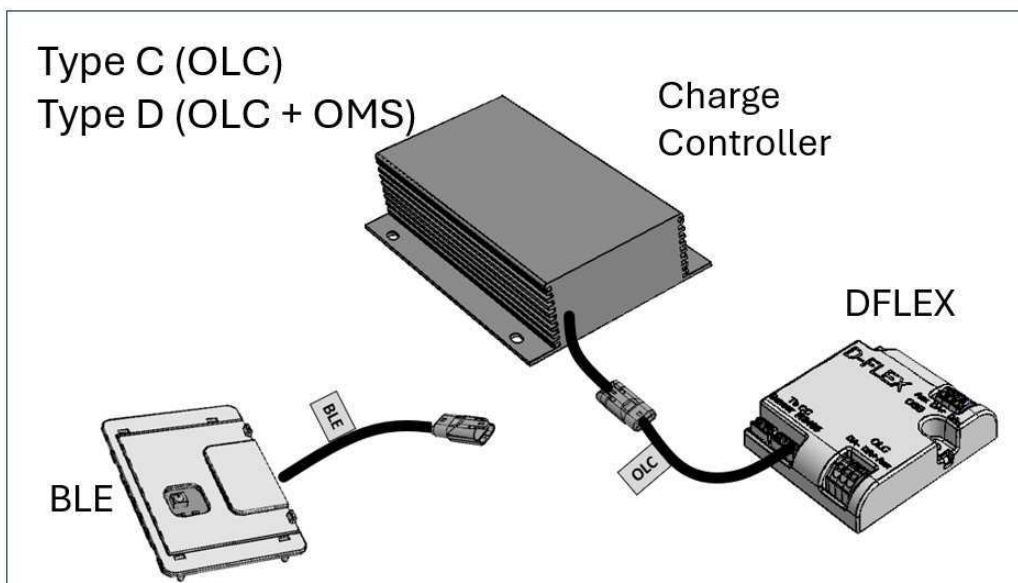

Contact your local SIGNIFY employee for further information





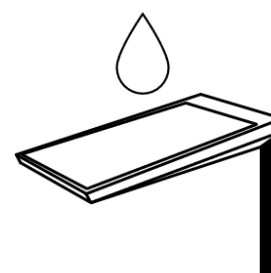



i Recommended luminaire cleaning

Cleaning interval months	Pollution category
12	High pollution
24	Low pollution
36	Clean environment



i Labelling

Watch out to the installation date. The battery is 70% level charged when leaving factory. Depending on storage time and ambient temperature, the battery can lose some charge.

 SunStay Pro gen2 12NC: 444000067	 SunStay Pro gen2 12NC: 444000067	 SunStay Pro gen2 VGP726	P.O. 444000067 QTY: 1 pce	  
Service Tag A721.444000067.0001 	Service Tag A721.444000067.0001 	System Power: 1W A721.444000067.0001 12NC/SKU:444000067 EOC: EAN:	Cust.Mat.: Cust.Order: Reference: PO Instr.:	Signify, I.B.R.S. 10461,5600 VB, NL Made in Spain Service Tag: A721.444000067.0001
		Sales Order/Line 999999/99 Made in Spain 25W20 Signify, I.B.R.S. 10461,5600 VB, NL		444000067 P.O. 444000067 Made in Spain VGP726 SunStay Pro gen2 ~220...240V 1W ta25°C Signify, I.B.R.S. 10461,5600 VB, NL SunStay Pro gen2 444000067 ~220...240V 1W Ta25°C Service Tag: A721.444000067.0001

The labels in the luminaire contain a QR code. For any contact with SIGNIFY regarding the product, please scan the QR code and keep it for reference.

i Service Tag



1 Scan me!
 A hand holds a smartphone displaying a 'Service tag' app with a 'DOWNLOAD' button. A speech bubble points to a QR code on a label.

2 A hand inserts the downloaded 'Service tag' app into a luminaire. A plus sign indicates the app is added to the luminaire's internal components.

3 Register me!
 A person scans the luminaire with a handheld scanner. A speech bubble points to a QR code on the luminaire's label.



To get an overview of all spare parts, service instructions and battery charging, please refer to detailed instructions in the Service Manual available via the SIGNIFY Service tag apps (Android and iOS).



- GB** Storage, installation, use, operation and maintenance of the products needs to be performed exactly according the instructions in this manual and/or other instructions as may be provided by us to guarantee safe use of the product over its entire lifetime. Failure to adhere to these instructions will invalidate your entitlement to warranty. Bolts with indication of torque strength on the drawing need to be tightened using a calibrated torque wrench. Pre-assembled bolts need to be retightened again to the required torque specification to assure maximum strength over lifetime.
- SP** El almacenamiento, instalación, uso, funcionamiento y mantenimiento de este producto debe realizarse exactamente según las instrucciones de este manual, así como otras instrucciones que le proporcionemos con el fin de garantizar un uso seguro del producto durante toda su vida útil. Si no se cumplen estas instrucciones, la garantía quedará anulada. Los tornillos con indicación de par de apriete en el dibujo, deben apretarse con una llave dinamométrica calibrada. Los tornillos del acoplamiento premontados deben reapretarse de nuevo con la especificación de par de apriete necesaria para garantizar una solidez máxima durante toda la vida útil de la luminaria.
- PT** Para garantir uma utilização segura do produto durante a respetiva vida útil, o armazenamento, a instalação, a utilização, a operação e a manutenção dos produtos tem de ser efetuados exatamente de acordo com as instruções neste manual e/ou com outras instruções que possam ser fornecidas por nós. O incumprimento destas instruções irá invalidar o direito a garantia. Os parafusos com indicação do torque no esquema tem de ser apertados utilizando uma chave dinamométrica calibrada. Os parafusos pré-montados tem de ser novamente apertados de acordo com a especificação de torque necessário para garantir uma resistência máxima durante a vida útil.
- DE** Lagerung, Installation, Verwendung, Betrieb und Wartung der Produkte müssen genau nach den Anweisungen in dieser Anleitung und/oder anderen von uns zur Verfügung gestellten Anweisungen erfolgen, um eine sichere Verwendung des Produkts über seine gesamte Lebensdauer zu gewährleisten. Bei Nichtbeachtung dieser Hinweise erlischt Ihr Anspruch auf Gewährleistung. Schrauben mit Angabe der Drehmomente auf der Zeichnung müssen mit einem kalibrierten Drehmomentschlüssel angezogen werden. Vormontierte Schrauben müssen mit dem angegebenen Drehmoment nachgezogen werden, um eine maximale Festigkeit über die gesamte Lebensdauer zu gewährleisten.
- FR** Le stockage, l'installation, l'utilisation et la maintenance des produits doivent être effectués conformément aux instructions de ce manuel et / ou d'autres instructions que nous fournissons afin de garantir une utilisation sûre du produit pendant toute sa durée de vie. Le non-respect de ces instructions invalidera votre droit à la garantie. Les vis, dont les couples de serrage sont indiqués sur les schémas, doivent être serrés à l'aide d'une clé dynamométrique étalonnée. Les vis, préassemblés, doivent être resserrés à nouveau selon la spécification de couple de serrage requise afin d'assurer leur résistance maximale pendant toute leur durée de vie.
- IT** La conservazione, l'installazione, l'uso, il funzionamento e la manutenzione dei prodotti devono essere eseguiti esattamente in base alle istruzioni contenute nel presente manuale e / o in altra documentazione fornita da noi per garantire la sicurezza del prodotto per l'intera durata del suo utilizzo. La mancata osservanza di queste istruzioni invaliderà la garanzia. I bulloni con indicazione sull'intensità della coppia serraggio sul disegno devono essere serrati utilizzando una chiave dinamometrica calibrata. I bulloni pre-assemblati devono essere riserrati nuovamente secondo le specifiche di coppia richieste per assicurare la massima resistenza per tutta la durata.
- NL** Om een veilig gebruik van dit product gedurende zijn hele levensduur te garanderen, dient het opslaan, installeren, gebruiken, bedienen en onderhouden ervan exact te worden uitgevoerd in overeenstemming met de instructies in deze handleiding en/of andere door ons geleverde instructies. Niet opvolgen van deze instructies maakt uw garantieaanspraken ongeldig. Bouten waarvan in de tekening het aanhaalkoppel is vermeld, dienen te worden vastgezet met behulp van een momentsleutel. Voor-geassembleerde bouten dienen opnieuw te worden aangehaald tot het vereiste koppel om maximale strekte gedurende de hele levensduur te waarborgen.
- DK** Opbevaring, installation, brug, betjening og vedligeholdelse af produkterne må kun udføres ifølge instruktionerne i denne vejledning og/eller eventuelle øvrige instruktioner fra Signify for at garantere sikker brug af produktet i hele dets levetid. Hvis disse instruktioner ikke følges, bortfalder produktgarantien. Bolte/skruer med angivet spændingsmoment på tegningen skal spændes med en indstillet momentnøgle. Færdigsamlende bolte/skruer skal efterspændes i henhold til det specificerede moment for at sikre maksimal fastgørelse i hele produktets levetid.
- SE** Förvaring, installation, användning, drift och underhall av produkterna måste utföras enligt instruktionerna i denna handbok och/eller andra instruktioner som kan tillhandahållas av oss för att garantera säker användning. Om instruktioner inte följs frångår man produktgarantin. Skruvar där vridmoment anges på ritningen måste dras åt med en kalibrerad skiftnyckel. Förmonterade skruvar måste dras åt igen med angivet vridmoment för att säkerställa högsta styrka under livslängden.
- NO** Oppbevaring, montering, bruk, drift og vedlikehold av produktene må utføres nøyaktig i samsvar med instruksjonene i denne handboken og/eller andre instruksjoner vi måtte gi for å garantere sikker bruk av produktet i hele dets levetid. Hvis instruksjonene ikke følges, bortfaller garantien. Bolter med angivelse av dreiemoment på tegningen må strammes med en kalibrert momentnøkkel. Ferdigmonterte bolter må strammes på nytt til pakkev dreiemoment for å sikre maksimal styrke i hele produktets levetid.
- FI** Tuotteiden asennuksessa, käytössä ja huollossa on noudatettava tarkoin tässä käyttöoppaassa tai muissa toimittamissamme ohjemateriaaleissa annettuja ohjeita. Tämä varmistaa tuotteen turvallisen toiminnan koko sen käyttöajan ajan. Näiden ohjeiden noudattamatta jättäminen mitätöi kaikki oikeutesi takuukorvauksiin. Pultit, joille on asennusohjeessa ilmoitettu tietty kiristystiukkuus, on kiristettävä kalibroidulla momenttiavaimella. Esiasennetut pultit on kiristettävä ilmoitettuun kiristystiukkuuteen koko käyttöajan mittaisen kestävyuden varmistamiseksi.
- HU** Pøi uchovávaní, montáži, používání a údržbi produktù je tøeba postupovat pøesnø podle pokynù v tøto pøíručce a dalších našich pøípadných pokynù, které zajišují bezpeèné používání produktù po celou dobu jejich životnosti. Když tyto pokyny dodržovat nebudete, pøijdete o záruku. Šrouby, které mají na výkresu uveden utahovací moment, je tøeba utahovat zkalibrovaným momentovým klíèem. Pøedem namontované šrouby je tøeba dotáhnout požadovaným momentem, aby po dobu životnosti produktu držely na místi.
- PL** Przechowywanie, instalacja, użytkowanie, obsługa i konserwacja produktów musi odbywać się ściśle według wytycznych zawartych w niniejszej instrukcji i / lub w innych instrukcjach, które dołączamy, aby zagwarantować bezpieczne użytkowanie produktu przez cały okres eksploatacji. Nieprzestrzeganie tych instrukcji może spowodować utratę prawa do gwarancji. Śruby, przedstawione na rysunku wskazującym siłę momentu dokręcania, muszą być dokręcone za pomocą kalibrowanego klucza dynamometrycznego. Aby zapewnić maksymalną wytrzymałość w całym okresie użytkowania, wstępnie zamontowane śruby należy dokręcić zgodnie z wymaganą specyfikacją momentu dokręcania.
- RO** Depozitarea, instalarea, utilizarea, operarea și întreținerea produselor trebuie să fie efectuate exact în conformitate cu instrucțiunile din acest manual și/sau cu alte instrucțiuni care pot fi furnizate de noi pentru a garanta utilizarea în siguranță a produsului, pe întreaga durată de viașă a acestuia. Nerespectarea acestor instrucțiuni vă va anula dreptul la garanție. Șuruburile care au cuplul de strângere indicat pe desen, trebuie să fie strânse cu ajutorul unei chei dinamometrice calibrate. Șuruburile preasamblate trebuie să fie strânse din nou la specificația de cuplu cerută, pentru a asigura rezistența maximă pe întreaga durată de viașă.
- CZ** Pøi uchovávaní, montáži, používání a údržbě produktù je tøeba postupovat pøesnø podle pokynù v tøto pøíručce a dalších našich pøípadných pokynù, které zajištují bezpeèné používání produktù po celou dobu jejich životnosti. Když tyto pokyny dodržovat nebudete, pøijdete o záruku. Šrouby, které mají na výkresu uveden utahovací moment, je tøeba utahovat zkalibrovaným momentovým klíèem. Pøedem namontované šrouby je tøeba dotáhnout požadovaným momentem, aby po dobu životnosti produktu držely na místi.
- TR** Ürünlerin saklanması, kurulumu, kullanımı, çalıştırılması ve bakımı, ürünün kullanımı ömrü boyunca güvenli kullanımının sağlanması amacıyla tam olarak bu kılavuzdaki ve/veya tarafımızdan sağlanan diğer talimatlara uygun biçimde gerçekleştirilmelidir. Söz konusu talimatlara uyulmaması, ürüne ilgili garanti hakkınızı geçersiz kılar. Teknik çizimdeyanında sıkma torku değeri belirtilen civatalar kalibre edilmiş bir tork anahtar kullanılarak sikilmalıdır. Önceden takılmış olarak gelen civataların da belirtilen tork değerine uygun biçimde yeniden sikılması, kullanım ömrü boyunca maksimum dayanıklılığın sağlanması açısından önemlidir.
- BG** Съхранението, инсталирането, употребата, експлоатацията и поддръжката на продуктите трябва да се извършват точно в съответствие с указанията в това ръководство и / или други инструкции, които могат да бъдат предоставени от нас, за да се гарантира безопасна употреба на продукта през целия му експлоатационен живот. Неспазването на тези указания ще обезсили Вашето право на гаранция. Болтовете с индикация за силата на въртящия момент на чертежа трябва да бъдат затегнати с помощта на калибриран гаечен ключ. Предварително слобените болтове трябва да бъдат отново затегнати до изискваната спецификация на въртящия момент, за да осигурят максимална якост по време на експлоатационния живот.



- GB** Storage, installation, use, operation and maintenance of the products needs to be performed exactly according the instructions in this manual and/or other instructions as may be provided by us to guarantee safe use of the product over its entire lifetime. Failure to adhere to these instructions will invalidate your entitlement to warranty. Bolts with indication of torque strength on the drawing need to be tightened using a calibrated torque wrench. Pre-assembled bolts need to be retightened again to the required torque specification to assure maximum strength over lifetime.
- SP** El almacenamiento, instalación, uso, funcionamiento y mantenimiento de este producto debe realizarse exactamente según las instrucciones de este manual, así como otras instrucciones que le proporcionemos con el fin de garantizar un uso seguro del producto durante toda su vida útil. Si no se cumplen estas instrucciones, la garantía quedará anulada. Los tornillos con indicación de par de apriete en el dibujo, deben apretarse con una llave dinamo métrica calibrada. Los tornillos del acoplamiento premontados deben reapretarse de nuevo con la especificación de par de apriete necesaria para garantizar una solidez máxima durante toda la vida útil de la luminaria.
- PT** Para garantir uma utilização segura do produto durante a respetiva vida útil, o armazenamento, a instalação, a utilização, a operação e a manutenção dos produtos tem de ser efetuados exatamente de acordo com as instruções neste manual e/ou com outras instruções que possam ser fornecidas por nós. O incumprimento destas instruções irá invalidar o direito a garantia. Os parafusos com indicação do torque no esquema tem de ser apertados utilizando uma chave dinamo métrica calibrada. Os parafusos pré-montados tem de ser novamente apertados de acordo com a especificação de torque necessário para garantir uma resistência máxima durante a vida útil.
- DE** Lagerung, Installation, Verwendung, Betrieb und Wartung der Produkte müssen genau nach den Anweisungen in dieser Anleitung und/oder anderen von uns zur Verfügung gestellten Anweisungen erfolgen, um eine sichere Verwendung des Produkts über seine gesamte Lebensdauer zu gewährleisten. Bei Nichtbeachtung dieser Hinweise erlischt Ihr Anspruch auf Gewährleistung. Schrauben mit Angabe der Drehmomente auf der Zeichnung müssen mit einem kalibrierten Drehmomentschlüssel angezogen werden. Vormontierte Schrauben müssen mit dem angegebenen Drehmoment nachgezogen werden, um eine maximale Festigkeit über die gesamte Lebensdauer zu gewährleisten.
- FR** Le stockage, l'installation, l'utilisation et la maintenance des produits doivent être effectués conformément aux instructions de ce manuel et / ou d'autres instructions que nous fournissons afin de garantir une utilisation sûre du produit pendant toute sa durée de vie. Le non-respect de ces instructions invalidera votre droit à la garantie. Les vis, dont les couples de serrage sont indiqués sur les schémas, doivent être serrés à l'aide d'une clé dynamométrique étalonnée. Les vis, préassemblés, doivent être resserrés à nouveau selon la spécification de couple de serrage requise afin d'assurer leur résistance maximale pendant toute leur durée de vie.
- IT** La conservazione, l'installazione, l'uso, il funzionamento e la manutenzione dei prodotti devono essere eseguiti esattamente in base alle istruzioni contenute nel presente manuale e / o in altra documentazione fornita da noi per garantire la sicurezza del prodotto per l'intera durata del suo utilizzo. La mancata osservanza di queste istruzioni invalida la garanzia. I bulloni con indicazione sull'intensità della coppia serraggio sul disegno devono essere serrati utilizzando una chiave dinamometrica calibrata. I bulloni pre-assemblati devono essere riserrati nuovamente secondo le specifiche di coppia richieste per assicurare la massima resistenza per tutta la durata.
- NL** Om een veilig gebruik van dit product gedurende zijn hele levensduur te garanderen, dient het opslaan, installeren, gebruiken, bedienen en onderhouden ervan exact te worden uitgevoerd in overeenstemming met de instructies in deze handleiding en/of andere door ons geleverde instructies. Niet opvolgen van deze instructies maakt uw garantieaanspraak ongedig. Bouten waarvan in de tekening het aanhaalkoppel is vermeld, dienen te worden vastgezet met behulp van een momentsleutel. Voor-geassembleerde bouten dienen opnieuw te worden aangehaald tot het vereiste koppel om maximale strekte gedurende de hele levensduur te waarborgen.
- DK** Opbevaring, installation, brug, betjening og vedligeholdelse af produkterne må kun udføres ifølge instruktionerne i denne vejledning og/eller eventuelle øvrige instruktioner fra Signify for at garantere sikker brug af produktet i hele dets levetid. Hvis disse instruktioner ikke følges, bortfalder produktgarantien. Bolte/skruer med angivet spændingsmoment på tegningen skal spændes med en indstillet momentnøgle. Færdigsamlede bolte/skruer skal efterspændes i henhold til det specificerede moment for at sikre maksimal fastgørelse i hele produktets levetid.
- SE** Förvaring, installation, användning, drift och underhall av produkterna måste utföras enligt instruktionerna i denna handbok och/eller andra instruktioner som kan tillhandahållas av oss för att garantera säker användning. Om instruktioner inte följs frångår man produktgarantin. Skruvar där vridmoment anges på ritningen måste dras åt med en kalibrerad skiftnyckel. Förmonterade skruvar måste dras åt igen med angivet vridmoment för att säkerställa högsta styrka under livslängden.
- NO** Oppbevaring, montering, bruk, drift og vedlikehold av produktene må utføres nøyaktig i samsvar med instruksjonene i denne handboken og/eller andre instruksjoner vi måtte gi for å garantere sikker bruk av produktet i hele dets levetid. Hvis instruksjonene ikke følges, bortfaller garantien. Bolter med angivelse av dreiemoment på tegningen må strammes med en kalibrert momentnøkkel. Ferdigmonterte bolter må strammes på nytt til pakvedt dreiemoment for å sikre maksimal styrke i hele produktets levetid.
- FI** Tuotteiden asennuksessa, käytössä ja huollossa on noudatettava tarkoin tässä käyttöoppaassa tai muissa toimittamissamme ohjemateriaaleissa annettuja ohjeita. Tämä varmistaa tuotteen turvallisen toiminnan koko sen käyttöajan. Näiden ohjeiden noudattamatta jättäminen mitätöi kaikki oikeutesi takuukorvauksiin. Pultit, jolle on asennusohjeessa ilmoitettu tietty kiristystiukkuus, on kiristettävä kalibroidulla momenttiavaimella. Esiasennetut pultit on kiristettävä ilmoitettuun kiristystiukkuuteen koko käyttöajan mittaisen kestävyyden varmistamiseksi.
- HU** Póci uchovávaní, montáži, používaní a údržbi produktú je třeba postupovať põesní podle pokynú v této pøiruèce a dalších našich pøipadných pokynú, které zajišují bezpečné používaní produktú po celou dobu jejich životnosti. Když tyto pokyny dodržovat nebudete, pøijdete o záruku. Šrouby, které mají na výkresu uveden utahovací moment, je třeba utahovat zkalibrovaným momentovým klíèem. Pøedem namontované šrouby je třeba dotáhnout požadovaným momentem, aby po dobu životnosti produktú držely na místi.
- PL** Przechowywanie, instalacja, użytkowanie, obsługa i konserwacja produktów musi odbywać się ściśle według wytycznych zawartych w niniejszej instrukcji i / lub w innych instrukcjach, które dołączamy, aby zagwarantować bezpieczne użytkowanie produktu przez cały okres eksploatacji. Nieprzestrzeganie tych instrukcji może spowodować utratę prawa do gwarancji. Śruby, przedstawione na rysunku wskazującym siłę momentu dokręcania, muszą być dokręcone za pomocą kalibrowanego klucza dynamometrycznego. Aby zapewnić maksymalną wytrzymałość w całym okresie użytkowania, wstępnie zamontowane śruby należy dokręcić zgodnie z wymaganą specyfikacją momentu dokręcenia.
- RO** Depozitarea, instalarea, utilizarea, operarea și întreținerea produselor trebuie să fie efectuate exact în conformitate cu instrucțiunile din acest manual și/sau cu alte instrucțiuni care pot fi furnizate de noi pentru a garanta utilizarea în siguranță a produsului, pe întreaga durată de viașă a acestuia. Nerespectarea acestor instrucțiuni vă va anula dreptul la garanție. Șuruburile care au cuplul de strângere indicat pe desen, trebuie să fie strânse cu ajutorul unei chei dinamometrice calibrate. Șuruburile preasamblate trebuie să fie strânse din nou la specificașia de cuplu cerută, pentru a asigura rezistenșă maximă pe întreaga durată de viașă.
- CZ** Pøi uchovávaní, montáži, používaní a údržbě produktú je třeba postupovat pøesně podle pokynú v této pøiruèce a dalších našich pøipadných pokynú, které zajištují bezpečné používaní produktú po celou dobu jejich životnosti. Když tyto pokyny dodržovat nebudete, pøijdete o záruku. Šrouby, které mají na výkresu uveden utahovací moment, je třeba utahovat zkalibrovaným momentovým klíèem. Pøedem namontované šrouby je třeba dotáhnout požadovaným momentem, aby po dobu životnosti produktú držely na místě.
- TR** Ürünlerin saklanması, kurulumu, kullanımı, çalıştırılması ve bakımı, ürünün kullanım ömrü boyunca güvenli kullanımının sağlanması amacıyla tam olarak bu kilavuzdaki ve/veya tarafımızdan sağlanan diğer talimatlara uygun biçimde gerçekleştirilmelidir. Söz konusu talimatlara uyulmaması, ürünü ilgili garanti hakkınızı geçersiz kılar. Teknik çizimdeyanında sıkma torku değeri belirtilen civatalar kalibre edilmiş bir tork anahtarı kullanılarak sıkılmalıdır. Önceden takılmış olarak gelen civataların da belirtilen tork değerine uygun biçimde yeniden sıkılması, kullanım ömrü boyunca maksimum dayanıklılığın sağlanması açısından önemlidir.
- BG** Съхранението, инсталирането, употребата, експлоатацията и поддръжката на продуктите трябва да се извършват точно в съответствие с указанията в това ръководство и / или други инструкции, които могат да бъдат предоставени от нас, за да се гарантира безопасна употреба на продукта през целия му експлоатационен живот. Неспазването на тези указания ще обезсили Вашето право на гаранция. Болтовете с индикация за силата на въртящия момент на чертежа трябва да бъдат затегнати с помощта на калибриран гаечен ключ. Предварително сглобените болтове трябва да бъдат отново затегнати до изискваната спецификация на въртящия момент, за да осигурят максимална якост по време на експлоатационния живот.



© 2025 Signify Holding

All rights reserved. The information provided herein is subject to change, without notice. Signify does not give any representation or warranty as to the accuracy or completeness of the information included herein and shall not be liable for any action in reliance thereon. The information presented in this document is not intended as any commercial offer and does not form part of any quotation or contract, unless otherwise agreed by Signify. All trademarks are owned by Signify Holding or their respective owners.

Signify Holding
The Netherlands